

PORT DESCRIPTIONS		
PORT#	TYPE	DESCRIPTION
ALL VALVES PORT 2	1/4 NPT	PRESSURIZED WHEN SOLENOID RECIEVES 24V SIGNAL EXTENDING PISTON
ALL VALVES PORT 3	1/4 NPT	PRESSURIZED WHEN SOLENOID POWER IS DISCONNECTED RETRACTING PISTON

NOTE: THIS ASSEMBLY COMES WITH TWO 3/8NPT MUFFLERS & THREE 3/8 NPT PLUGS. MUFFLERS CAN BE USED ON EITHER THE LEFT OR RIGHT HAND PORTS, BUT THERE MUST BE AT LEAST ONE MUFFLER ON BOTH CIRCUIT 2&3. AIR INLET CAN ALSO BE ON EITHER SIDE. ALL UNUSED PORTS SHOULD BE PLUGGED!

CIRCUIT 2 (LEFT PORT)  
3/8 NPT EXHAUST PORT  
(SHOWN WITH MUFFLER)

CIRCUIT 1 (LEFT PORT)  
3/8 NPT INLET PORT  
150 PSI MAXIMUM

CIRCUIT 3 (LEFT PORT)  
3/8 NPT EXHAUST PORT  
(SHOWN WITH MUFFLER)

CIRCUIT 2 (RIGHT PORT)  
3/8 NPT EXHAUST PORT  
(SHOWN WITH PLUG)

CIRCUIT 1 (RIGHT PORT)  
3/8 NPT INLET PORT  
(SHOWN WITH PLUG)

CIRCUIT 3 (RIGHT PORT)  
3/8 NPT EXHAUST PORT  
(SHOWN WITH PLUG)

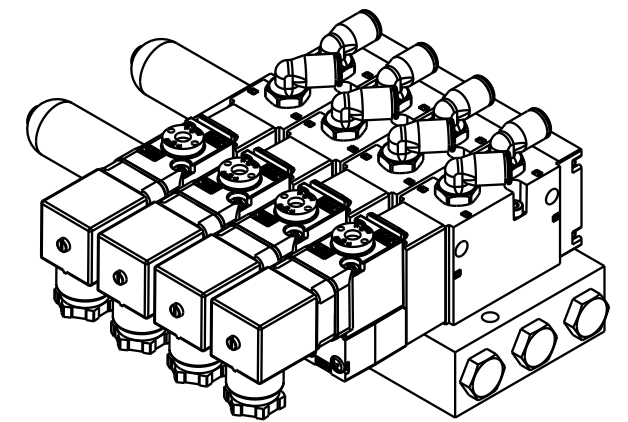

ILCP7101214 REV A ECN#5120

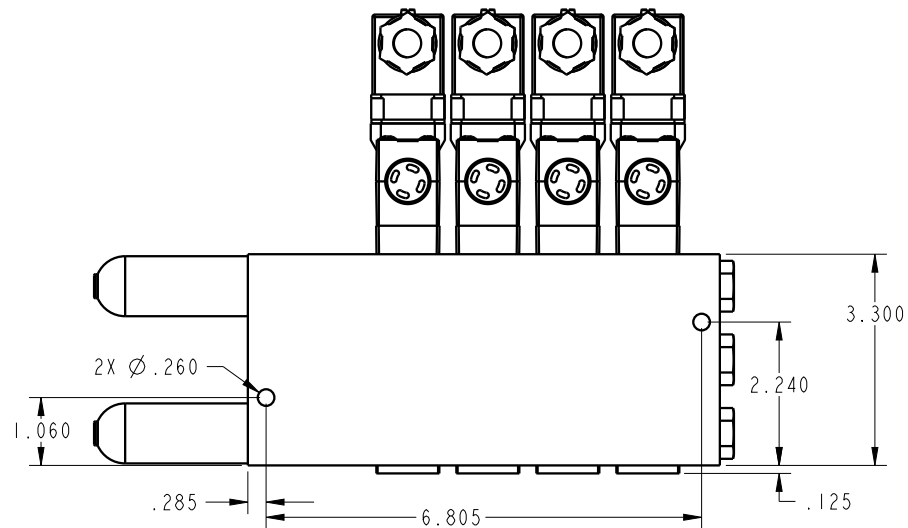
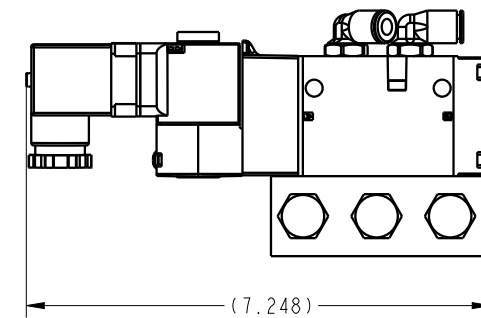
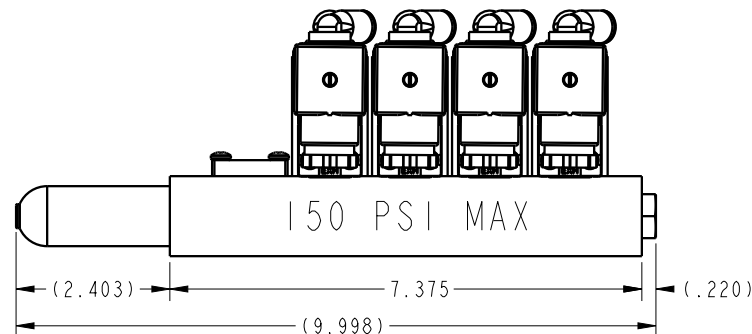
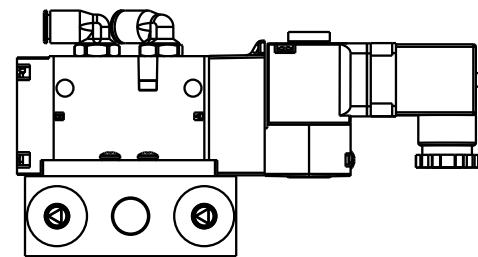

RECOMENDED VALVE USES AND SETUP		
VALVE OPTION	ALL VALVES PORT 2	ALL VALVES PORT 3
AUTOCOUPLER SLIDE	TO PORT P7 ON SLIDE (EXTEND)	TO PORT P6 ON SLIDE (RETRACT)
AUTOCOUPLER/PALLET RECIEVER LOCK	TO PORT P3 (LOCKS AUTOCOUPLER)	TO PORT P4 (UNLOCKS AUTOCOUPLER)
AIR BLOWOFF	TO PORT P5 ON AUTOCOUPLER (AIR BLOWOFF ON)	NOT USED
AUTOCOUPLER AIR THROUGH PORT 1	TO PORT P1 ON AUTOCOUPLER	NOT USED
AUTOCOUPLER AIR THROUGH PORT 2	TO PORT P2 ON AUTOCOUPLER	NOT USED

NOTE: ONLY FOUR OF THE ABOVE FEATURES CAN BE USED WITH THIS MODEL!

CAD CONTROL DRAWING



VEKTEK, INC.  
1334 E. SIXTH AVE. P.O. BOX 625  
EMPORIA, KS. 66801 U.S.A.

A	5120	RELEASE	BDC	7/10/23	P7101214	A	ILC, VALVE, PNEU, 5/2, 24V, SGL SOL, 4 BANK
REV	IN ACCORDANCE WITH ECN	EFFECTIVE DATE	REVISED BY	DATE	REFERENCE MODEL	REF REV	
DRW BY:	BDC	DRAWING STATUS: Design			TOLERANCES DO NOT APPLY DIMENSIONS ARE NOMINAL		SIZE B
DATE:	7/10/23	PRODUCTION APPROVED FOR RELEASED STATUS ONLY					ILCP7101214 REV A

FORM FEG036, Rev. B