

1

2

3

4

D

D

C

C

B

B

A

A

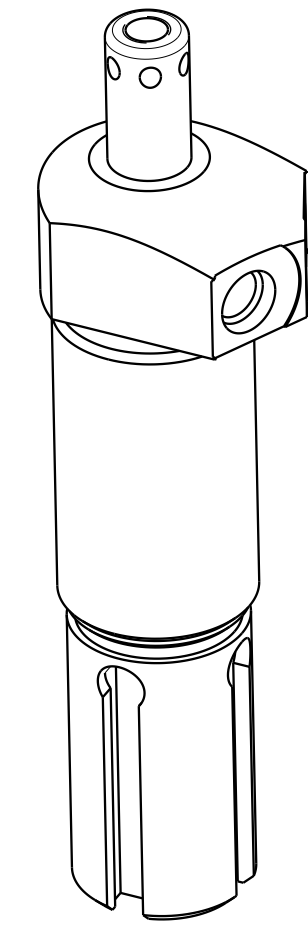

ILC14020501RPS REV D ECN 4186

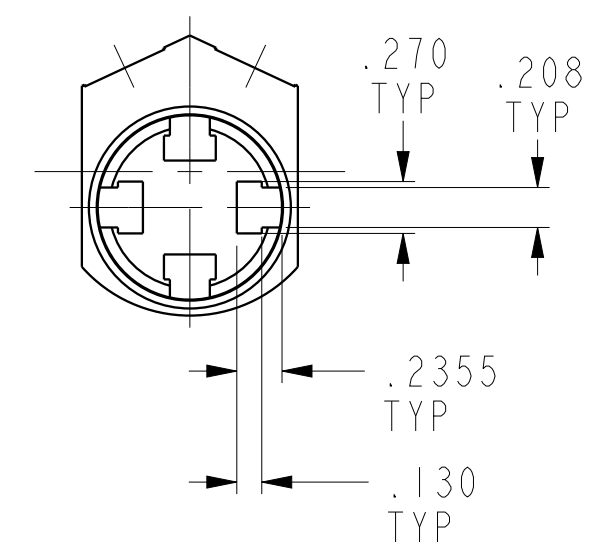
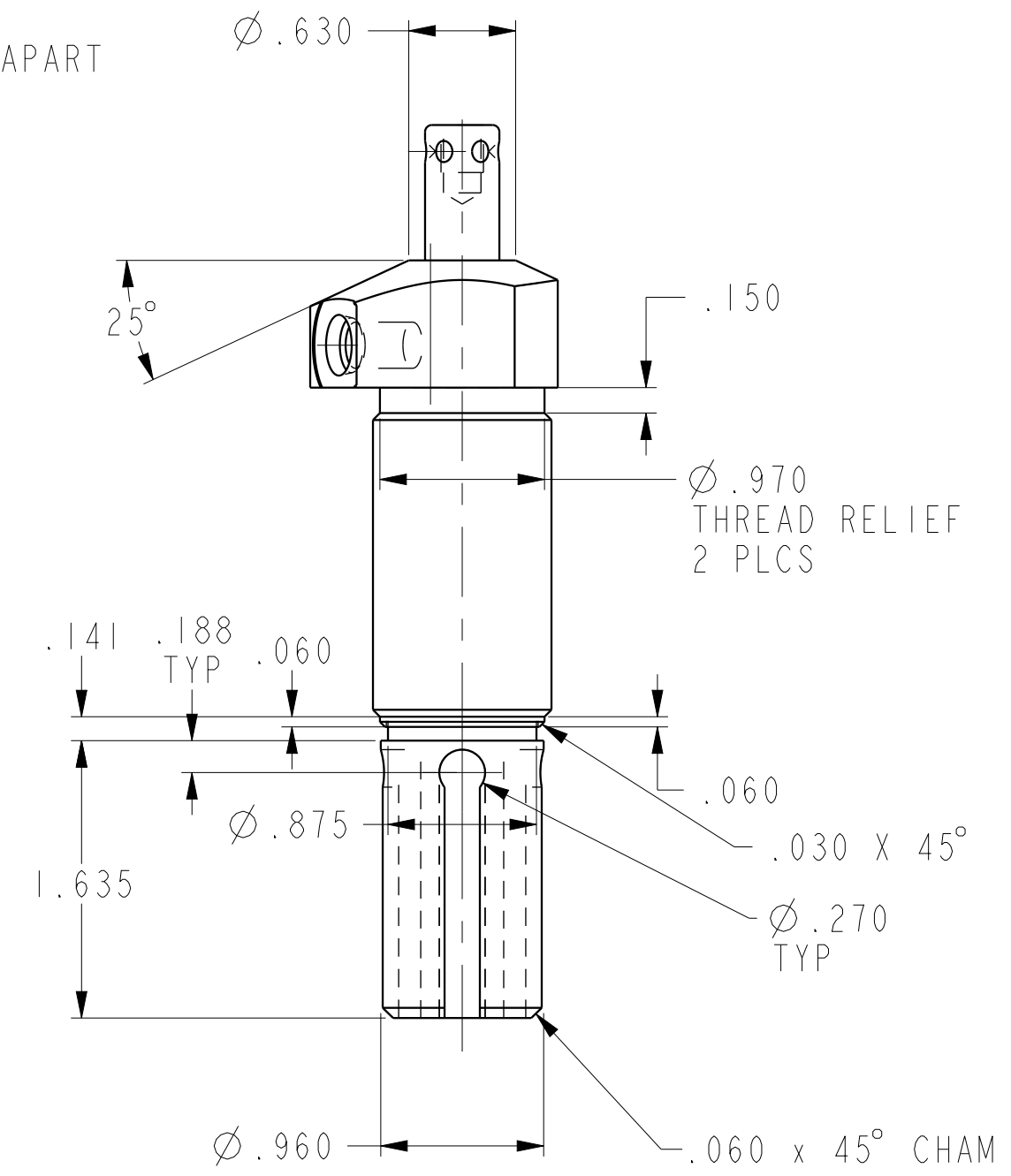
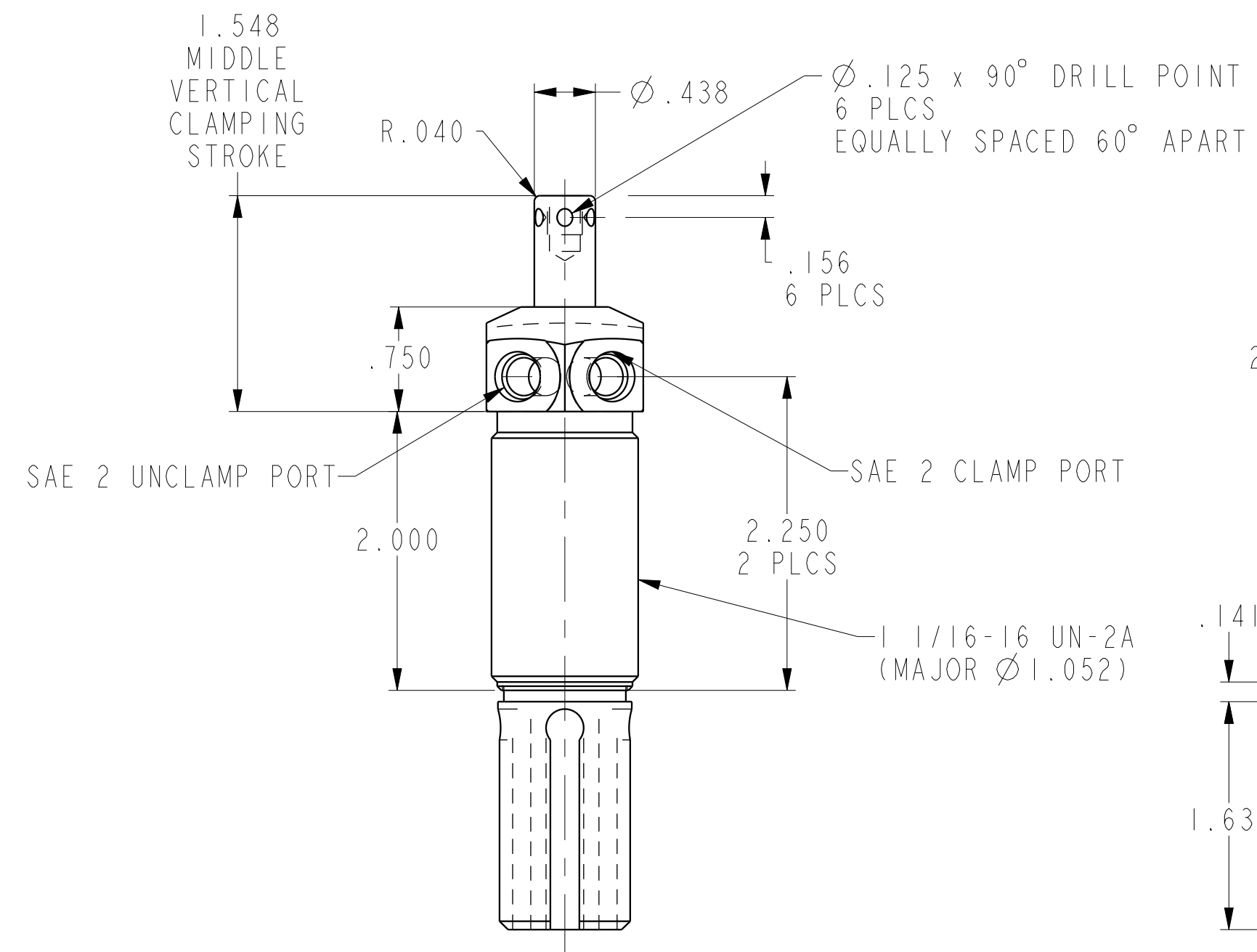
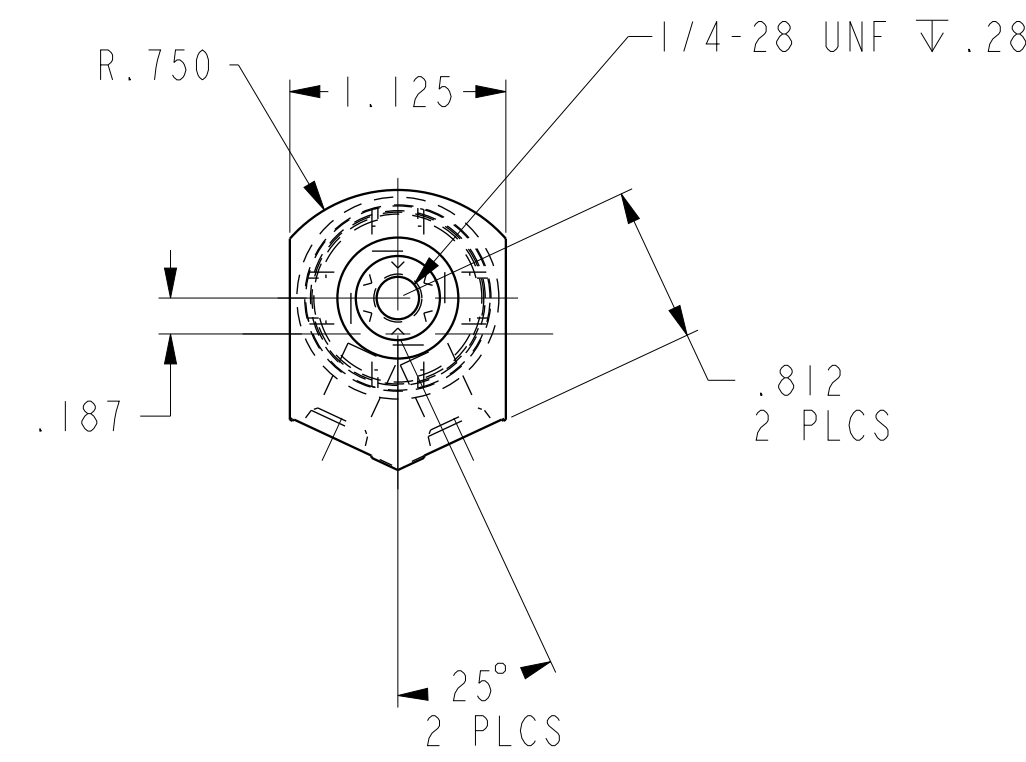

CAD CONTROL DRAWING

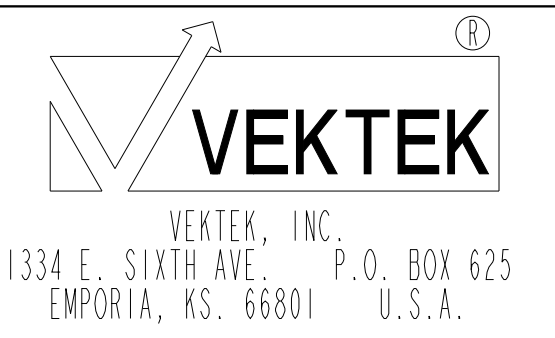

D	4186	RELEASE	JDW	07/03/20
REV	IN ACCORDANCE WITH ECN	EFFECTIVE DATE	REVISED BY	DATE
DRW BY:	DRAWING STATUS: Released			
DATE:	PRODUCTION APPROVED FOR RELEASED STATUS ONLY			

14020501RPS	A
REFERENCE MODEL	REF REV
TOLERANCES DO NOT APPLY DIMENSIONS ARE NOMINAL	

SIZE	D	REV	D
ILC14020501RPS			

1

2

3

4

SHEET 1 OF 1