

1

2

3

4

D

D

C

C

B

B

A

A

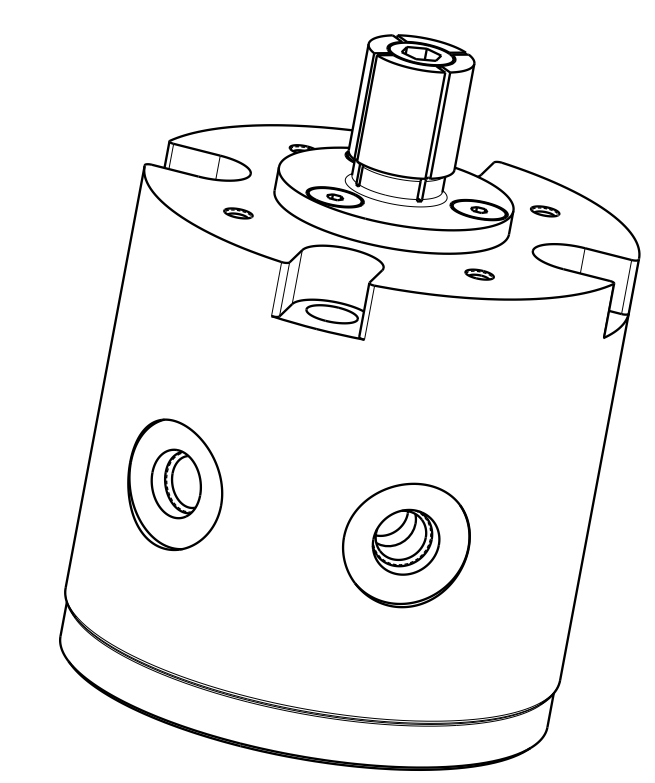
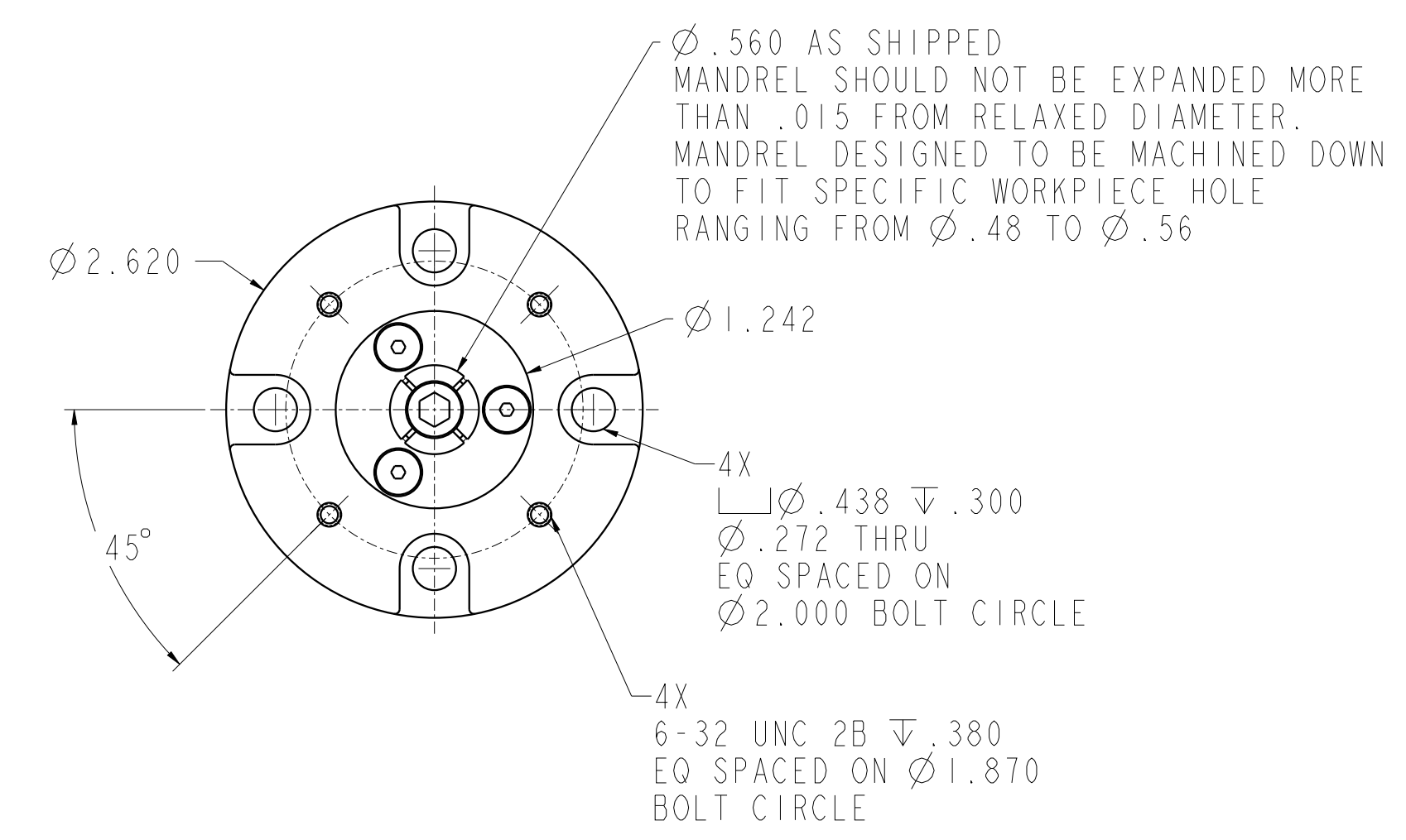

ILC15521000 REV A ECN 4221

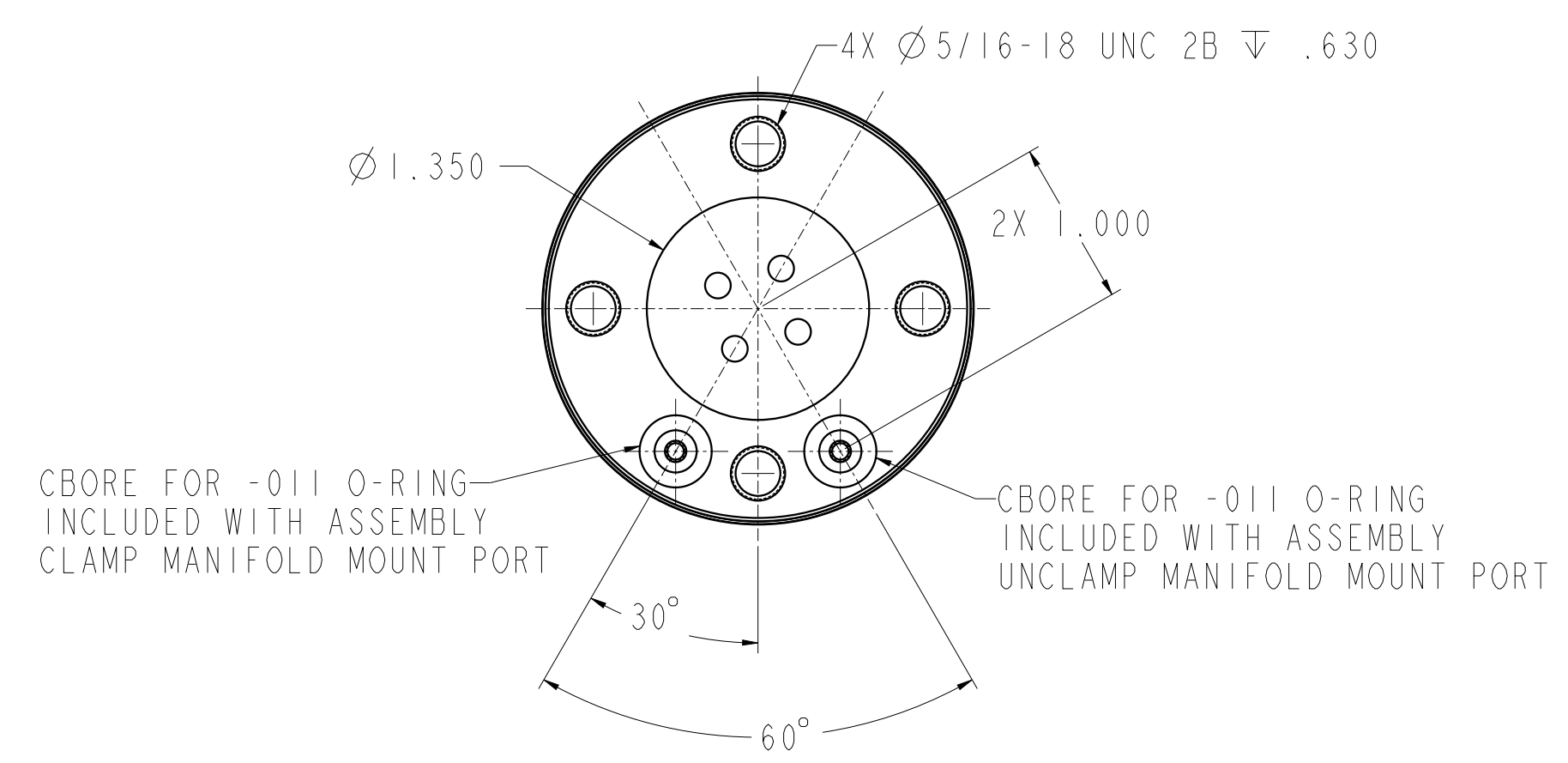
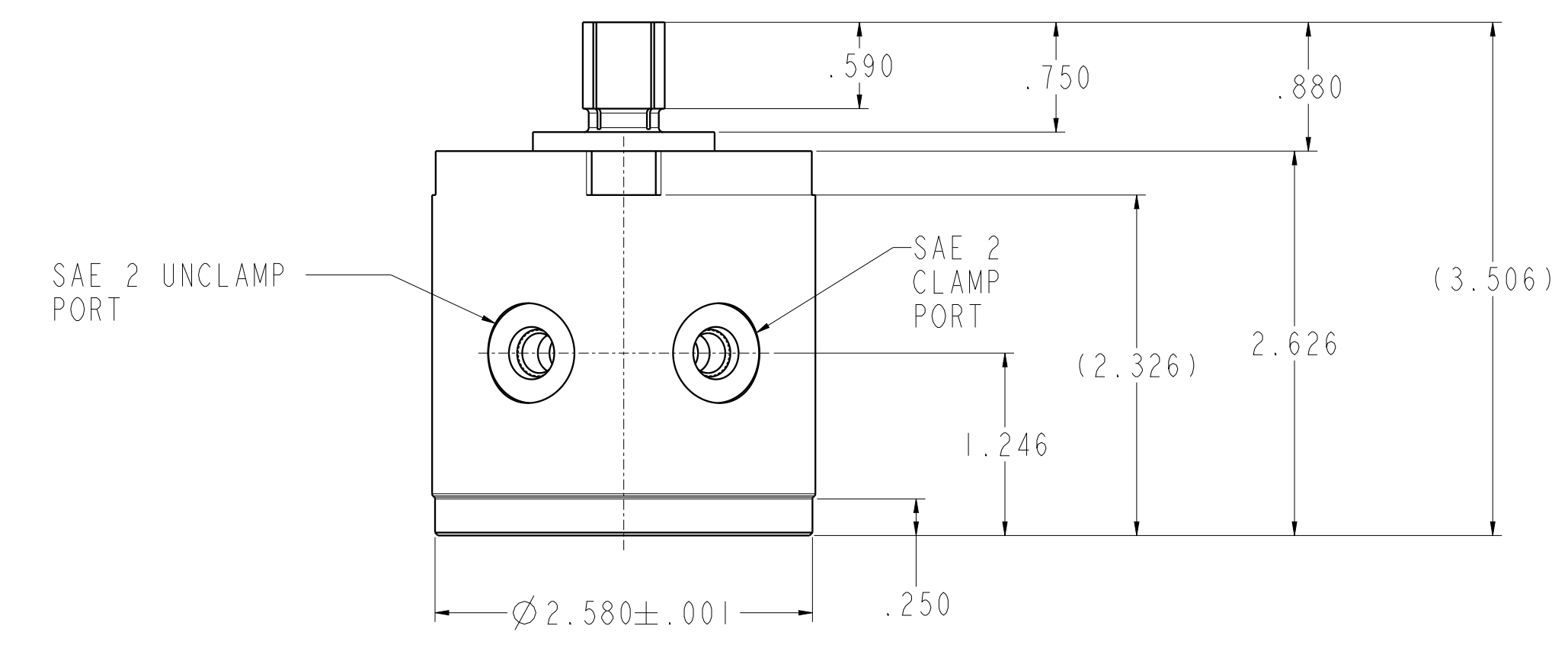
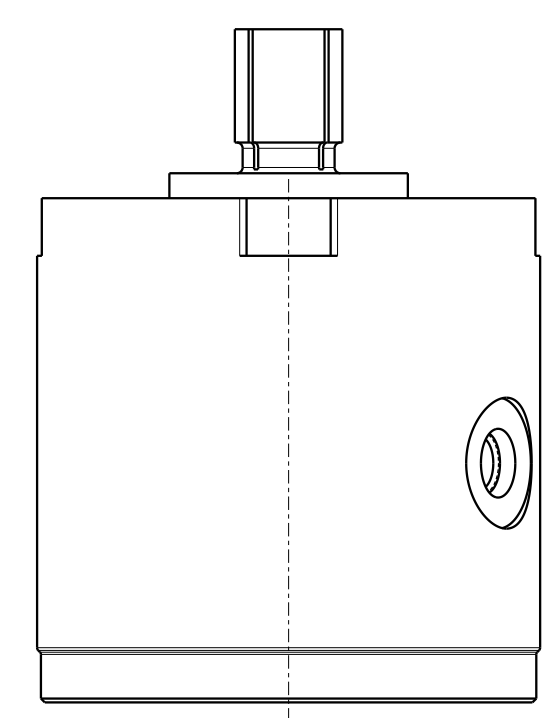

**CAD CONTROL DRAWING**

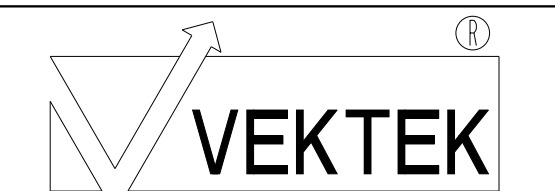

VEKTEK, INC.  
 1334 E. SIXTH AVE. P.O. BOX 625  
 EMPORIA, KS. 66801 U.S.A.

A	4221	RELEASE	ALS	8/26/22
REV	IN ACCORDANCE WITH ECN	EFFECTIVE DATE	REVISED BY	DATE
DRW BY:	DLG	DRAWING STATUS: Released		
DATE:	05/15/2020	PRODUCTION APPROVED FOR RELEASED STATUS ONLY		

15521000	A	CLAMP, ID, EXPANSTION, 2950, #1
REFERENCE MODEL	REF REV	1/4-20 PISTON THREAD
TOLERANCES DO NOT APPLY DIMENSIONS ARE NOMINAL		SIZE D

ILC15521000	REV A
FORM FEG036, Rev. B	

1

2

3

4

SHEET 1 OF 1