

ILC21411601 REV A ECN 2802

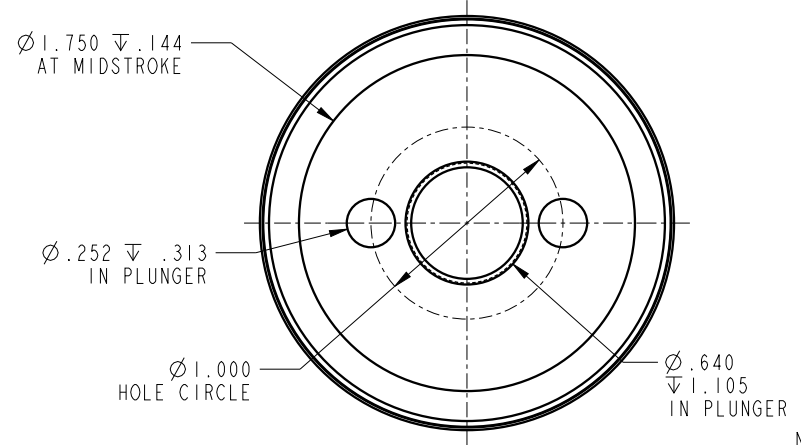

NOTE: RETURN SPRING INCLUDED WITH CYLINDER.
 SPRING OMITTED FOR CLARITY

**CAD CONTROL
 DRAWING**

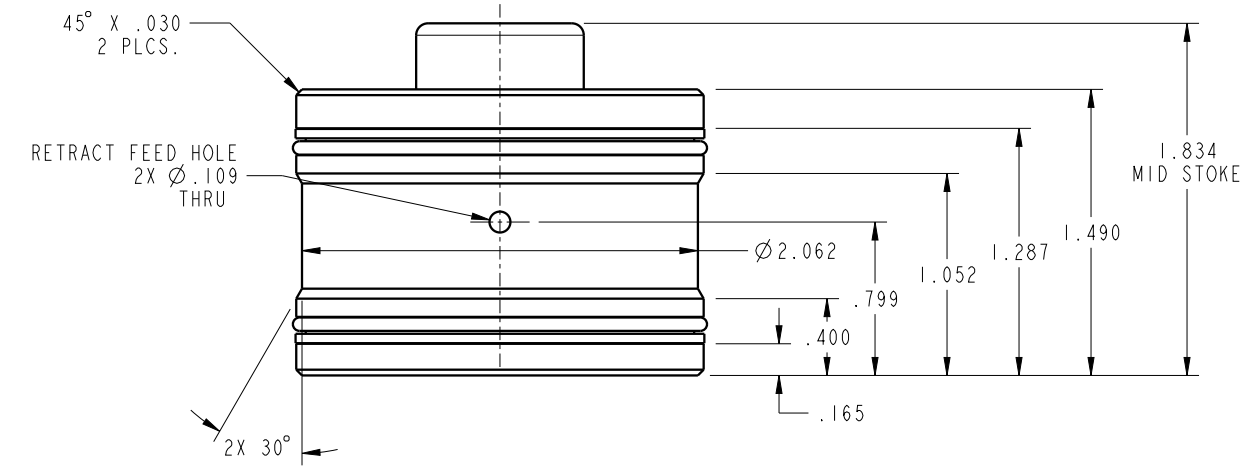

A	2802	RELEASE	DKC	3/3/15
REV	IN ACCORDANCE WITH ECN	EFFECTIVE DATE	REVISED BY	DATE
DRW BY:	DKC	DRAWING STATUS: Released		
DATE:	8/21/14	PRODUCTION APPROVED FOR RELEASED STATUS ONLY		

21411601	A	CYL, CM, PULL, 9000LB
REFERENCE MODEL	REF REV	5/8-11 THREAD
TOLERANCES DO NOT APPLY DIMENSIONS ARE NOMINAL		SIZE B
ILC21411601		REV A

FORM FEG036, Rev. B