

1

2

3

4

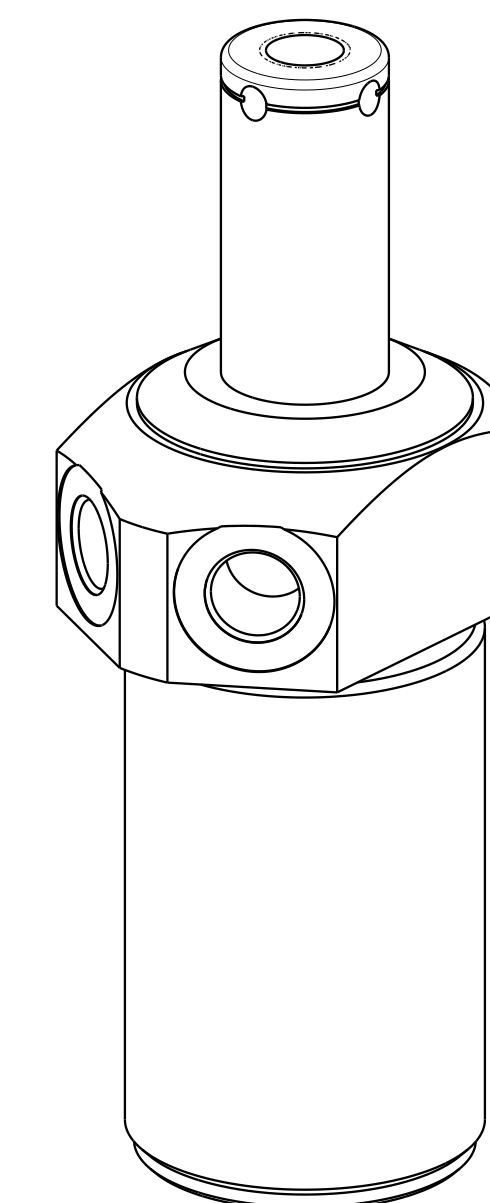
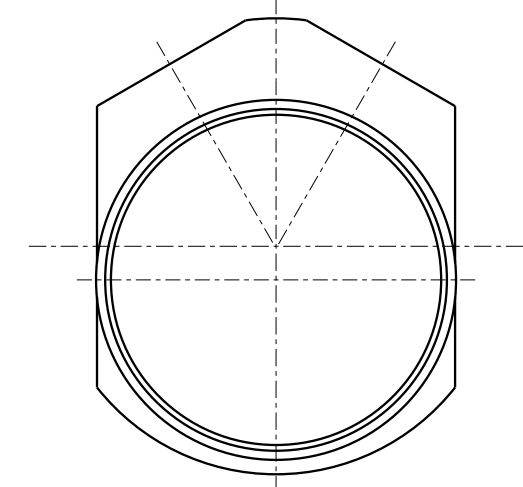

I L C M 4 1 5 0 1 1 2 5 REVD ECN5049

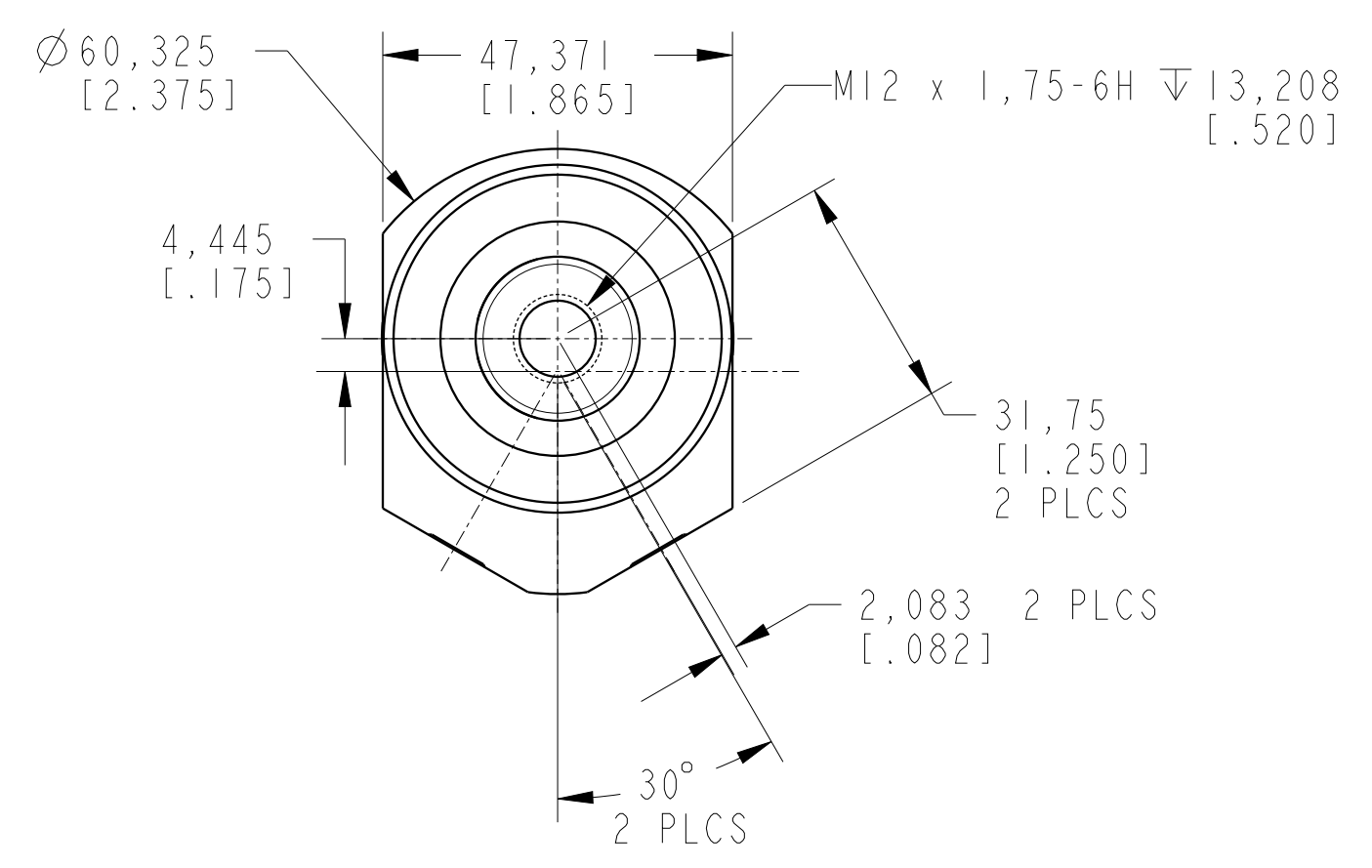
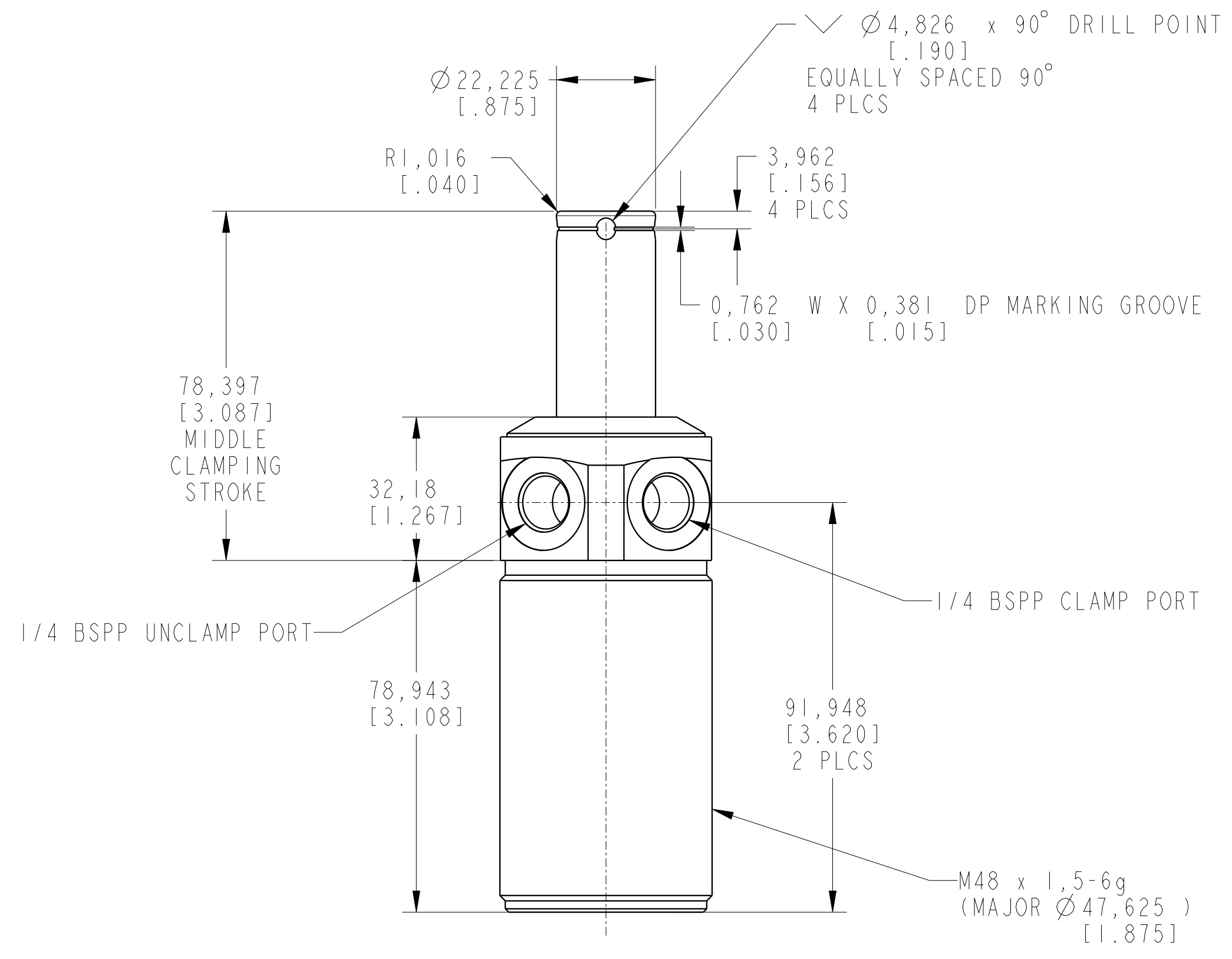
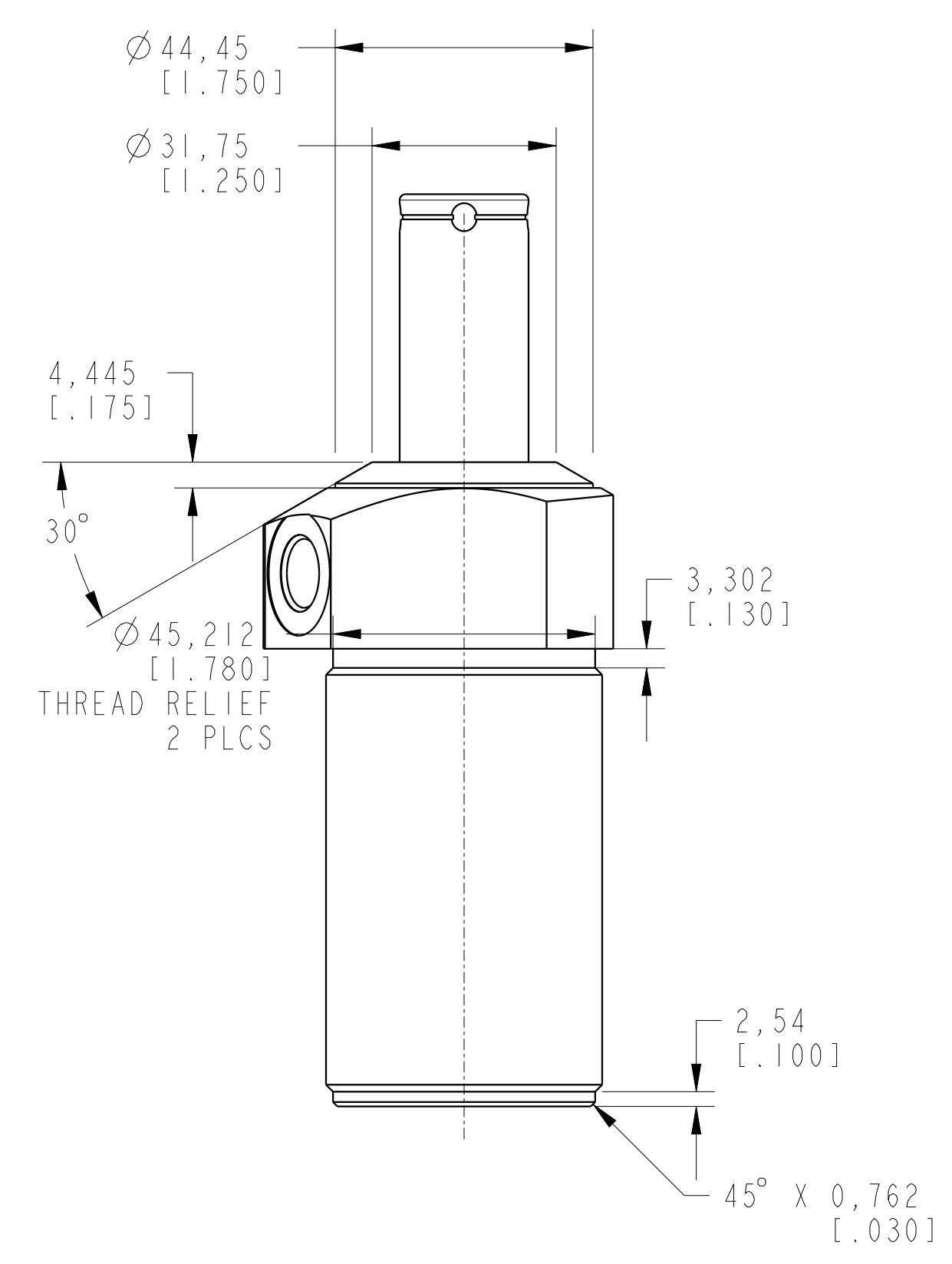

CAD CONTROL DRAWING

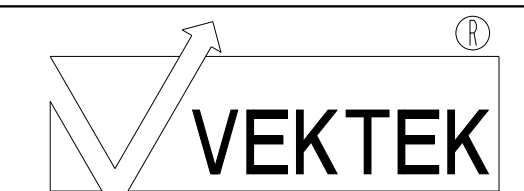

VEKTEK, INC.
1334 E. SIXTH AVE. P.O. BOX 625
EMPORIA, KS. 66801 U.S.A.

B	5049	RELEASE	JDW	03/21/23	41501125	D	SC, TB, 11.6 KN, DA, STR
REV	IN ACCORDANCE WITH ECN	EFFECTIVE DATE	REVISED BY	DATE	REFERENCE MODEL	REF REV	****
DRW BY:	ALS	DRAWING STATUS: Released			TOLERANCES DO NOT APPLY	UNITS	SIZE
DATE:	11/23/21	PRODUCTION APPROVED FOR RELEASED STATUS ONLY			DIMENSIONS ARE NOMINAL	mm (inch)	D I L C M 4 1 5 0 1 1 2 5

SHEET 1 OF 1

1

2

3

4