

ILCMV41621540 REV B ECN 5240

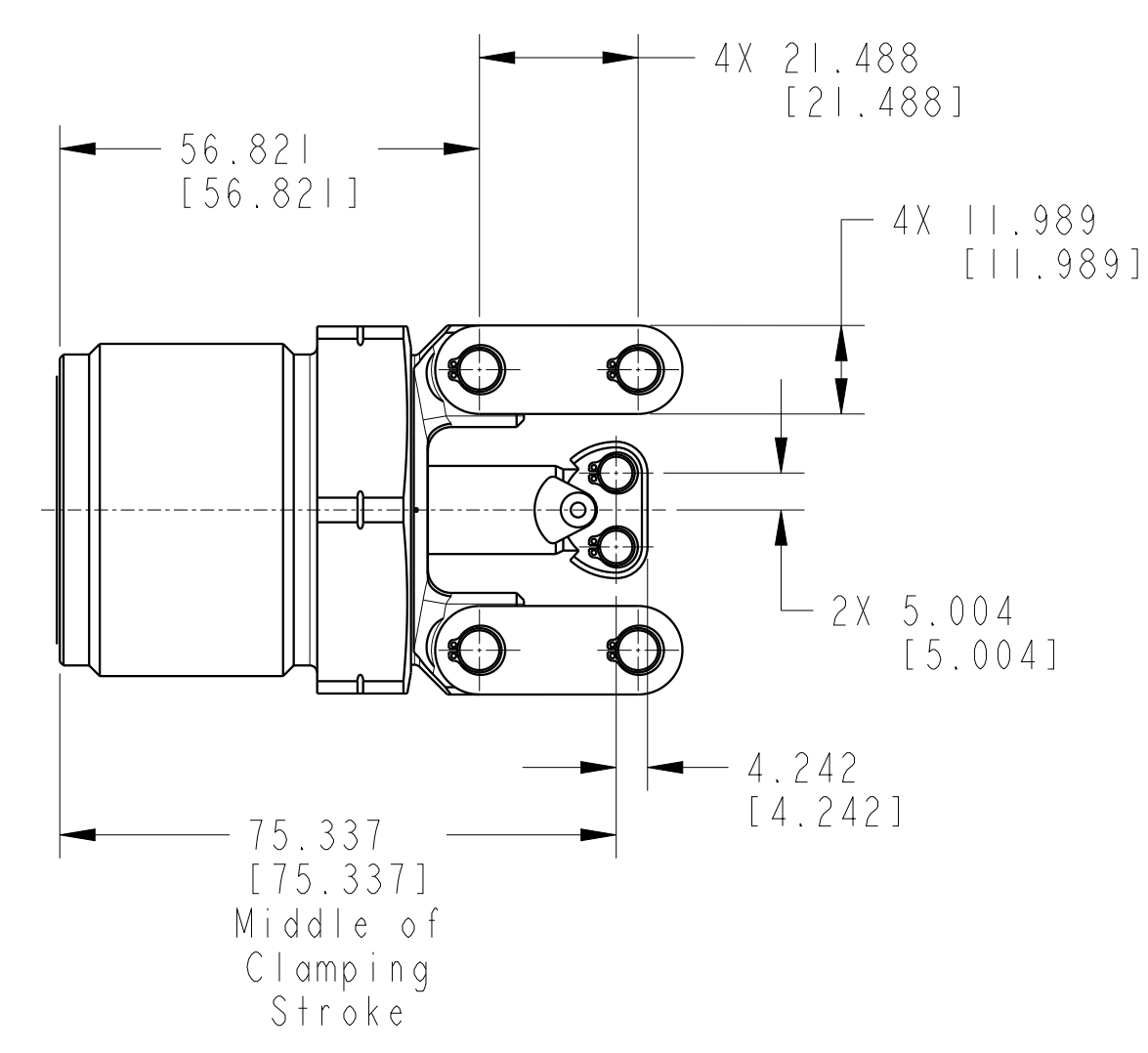

CAD CONTROL DRAWING

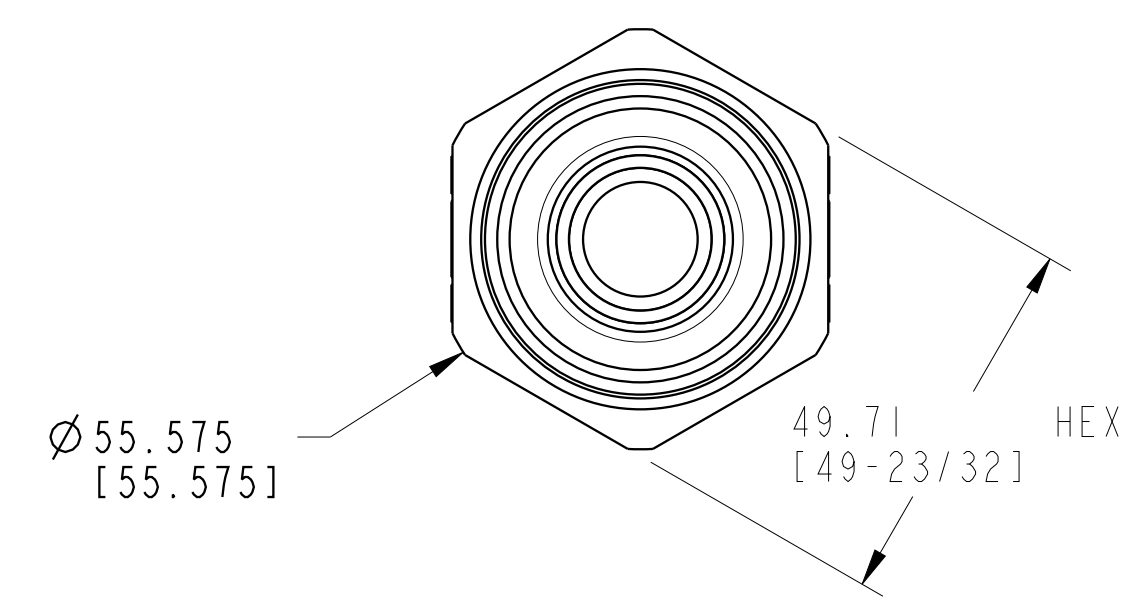
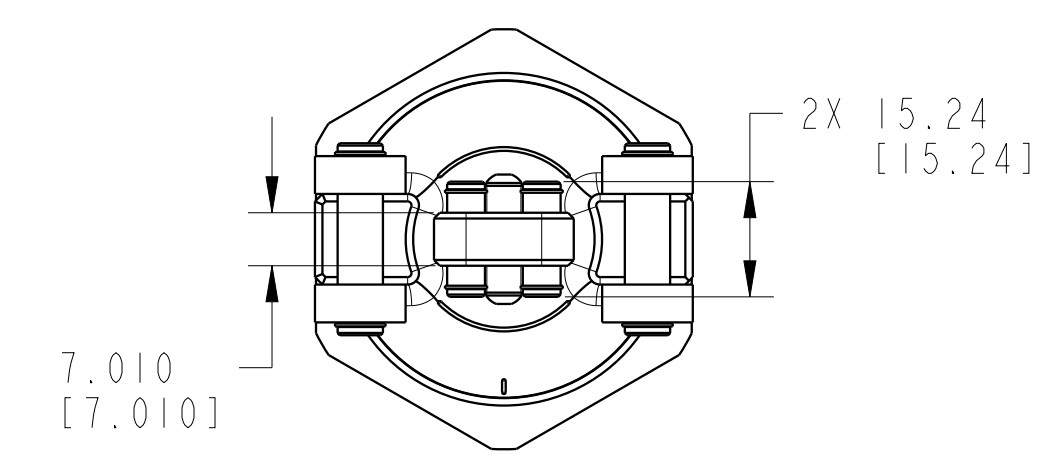
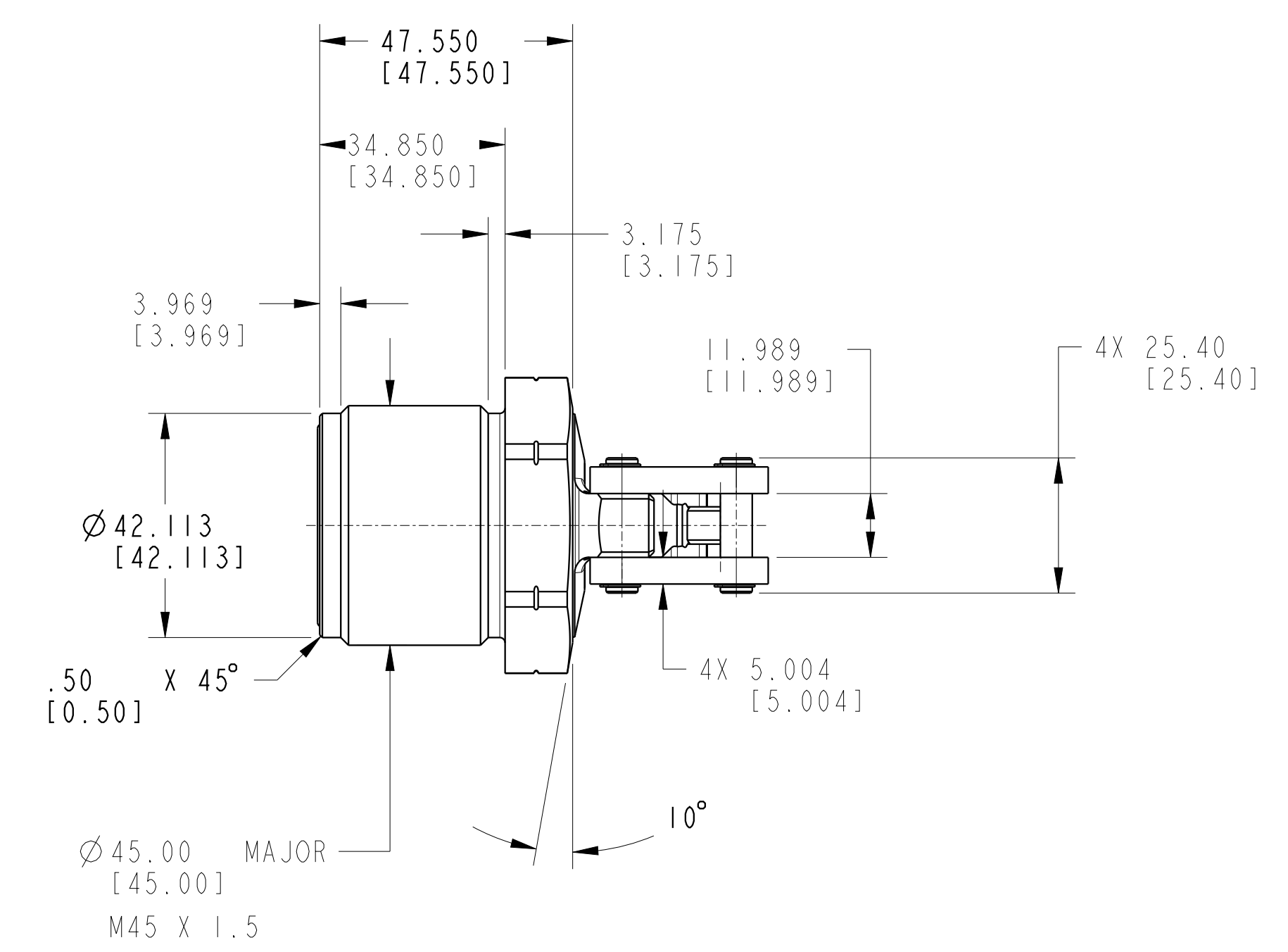
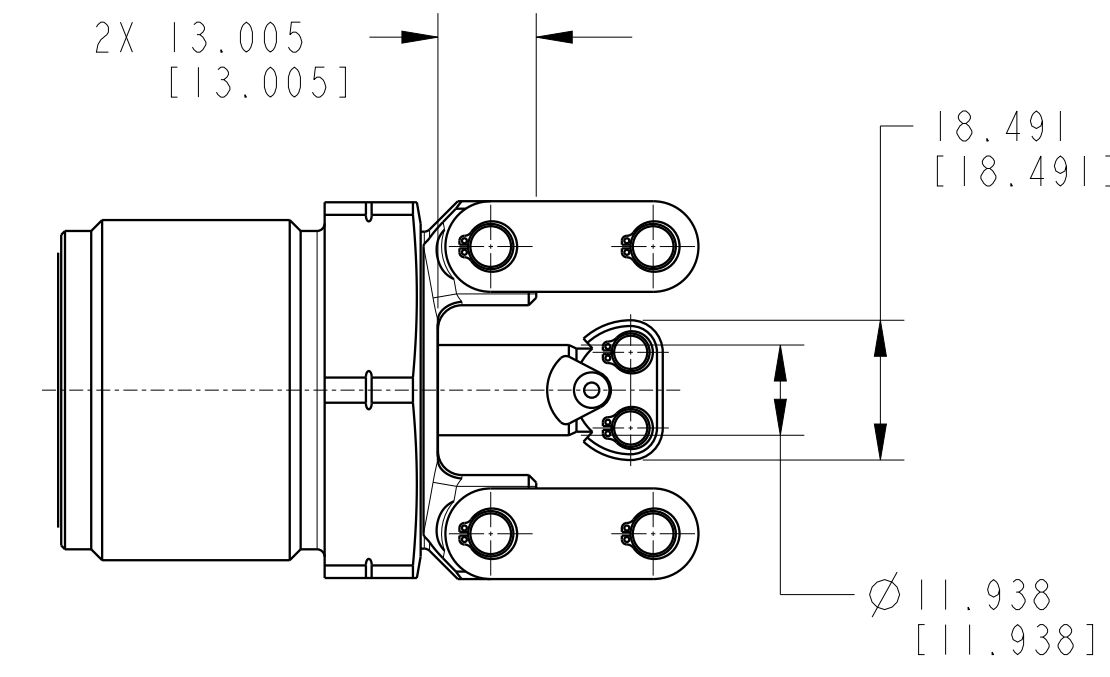

VEKTEK, INC.
1334 E. SIXTH AVE. P.O. BOX 625
EMPORIA, KS. 66801 U.S.A.

B	5240	RELEASE	BDC	2/23/24	41621540	A	ILCMV, LC, CM, TL360-TWIN, DA, 4.89kN
REV	IN ACCORDANCE WITH ECN	EFFECTIVE DATE	REVISED BY	DATE	REFERENCE MODEL	REF REV	
DRW BY:	A.THOMSEN	DRAWING STATUS: Released			TOLERANCES DO NOT APPLY	UNITS	SIZE
DATE:	25-MAY-2020	PRODUCTION APPROVED FOR RELEASED STATUS ONLY			DIMENSIONS ARE NOMINAL	mm (inch)	D
							ILCMV41621540
							REV B