

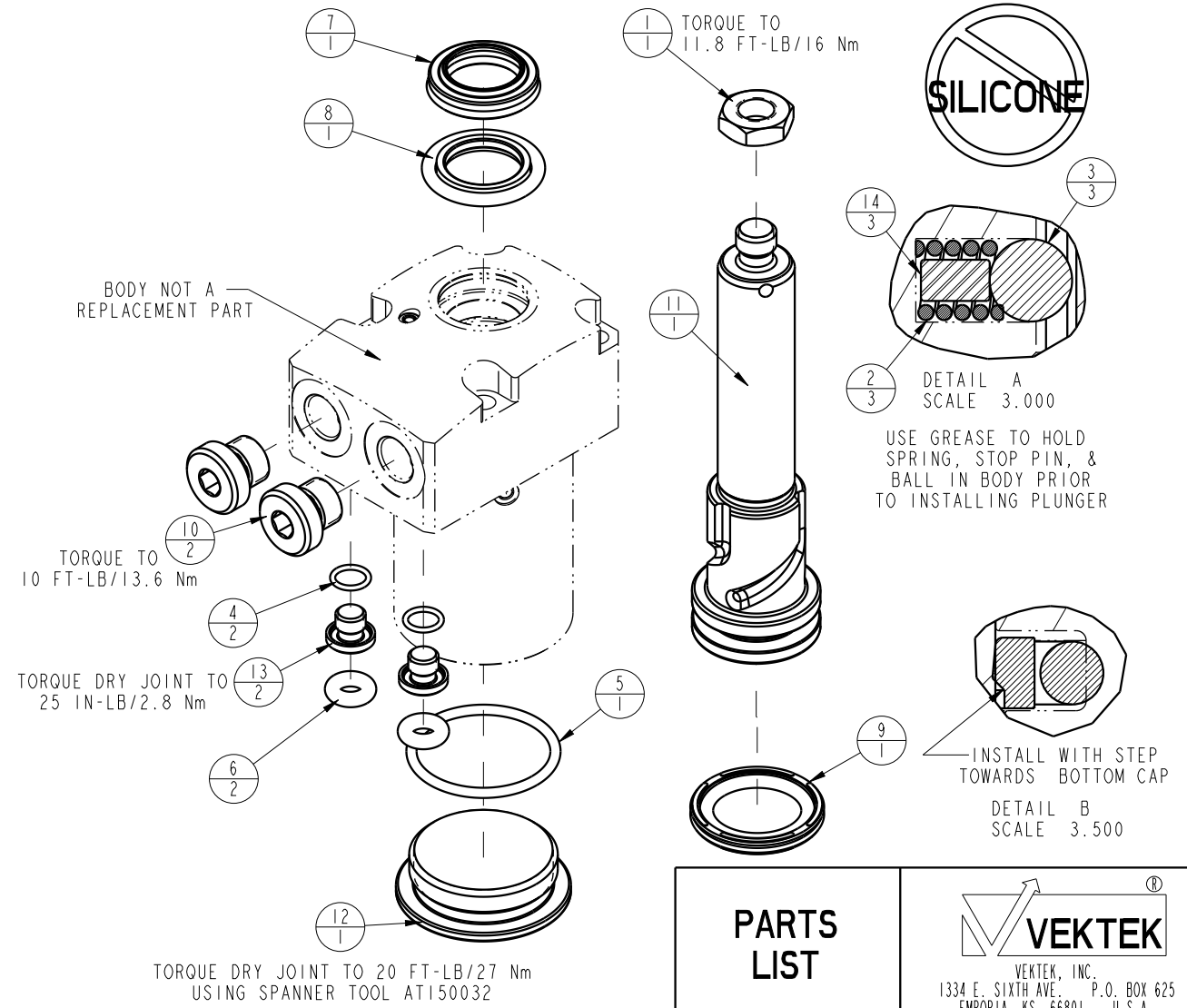

NO	QTY	PART NO	DESCRIPTION	SEAL KIT
1	1	21510000	NUT, JAM, HEX, M8-1.00	
2	3	23350085	SPRING, COMPRESSION	X
3	3	23650009	BALL, TUNGSTEN-CARBIDE, 4mm	X
4	2	39051079	O-RING, (6mm X 1)	X
5	1	39051081	O-RING, (26mm X 2)	X
6	2	39051087	O-RING, (4mm X 3)	X
7	1	39053041	SEAL, WIPER, SNAP IN, WED, 15, 94A, AU	X
8	1	39056001	SEAL, STEP, ROD, 15	X
9	1	39056021	SEAL, CAP, PISTON, 25, 90A, AU GRPHT FLD	X
10	2	43068004	PLUG, SOCH, G1/8	
11	1	81400141	PLUNGER, SC, 7MPa, 25B, RH	
12	1	81400151	CAP, LC/SC, 7MPa, 25B	
13	2	81400200	PLUG, MANIFOLD, 7MPa, M6	
14	3	81400202	PIN, STOP, BALL, METRIC, 4mm BALL	X
N/A	N/A	L6014250	KIT, SEAL, SC, 7MPa, 25B	NOTED



PARTS LIST	 VEKTEK VEKTEK, INC. 1334 E. SIXTH AVE. P.O. BOX 625 EMPORIA, KS. 66801 U.S.A.
	ASSEMBLIES AFFECTED L1402500R
PARTS LIST, ASSY, SC, TF, 7MPa, 25B, RH *****	SIZE A
LPL1401	REV B

B	3273	RELEASE	JDW	08/15/18
REV	IN ACCORDANCE WITH ECN	EFFECTIVE DATE	REVISED BY	DATE
DRW BY:	QMITCHELL	DRAWING STATUS: Released		
DATE:	7-17-13	PRODUCTION APPROVED FOR RELEASED STATUS ONLY		