

| NO | QTY | PART NO | DESCRIPTION | SEAL KIT |
|-----|-----|----------|--|----------|
| 1 | 1 | 21510004 | NUT, JAM, HEX, M18-1.50 | |
| 2 | 3 | 23350087 | SPRING, COMPRESSION | X |
| 3 | 3 | 23650011 | BALL, TUNGSTEN-CARBIDE, 8mm | X |
| 4 | 2 | 39051080 | O-RING, (10mm X 1) | X |
| 5 | 1 | 39051085 | O-RING, (63mm X 2) | X |
| 6 | 2 | 39051088 | O-RING, (8mm X 3) | X |
| 7 | 1 | 39053046 | SEAL, WIPER, SNAP IN, WED, 36, 94A, AU | X |
| 8 | 1 | 39056006 | SEAL, STEP, ROD, 36 | X |
| 9 | 1 | 39056025 | SEAL, CAP, PISTON, 63, 90A, AU GRPHT FLD | X |
| 10 | 2 | 43068006 | PLUG, PORT, HOLLOW HEX, G1/4 | |
| 11 | 1 | 81400145 | PLUNGER, SC, 7MPα, 63B, RH | |
| 12 | 1 | 81400155 | CAP, LC/SC, 7MPα, 63B | |
| 13 | 2 | 81400201 | PLUG, MANIFOLD, 7MPα, M10 | |
| 14 | 3 | 81400204 | PIN, STOP, BALL, METRIC, 8mm BALL | X |
| N/A | N/A | L6014630 | KIT, SEAL, SC, 7MPα, 63B | NOTED |

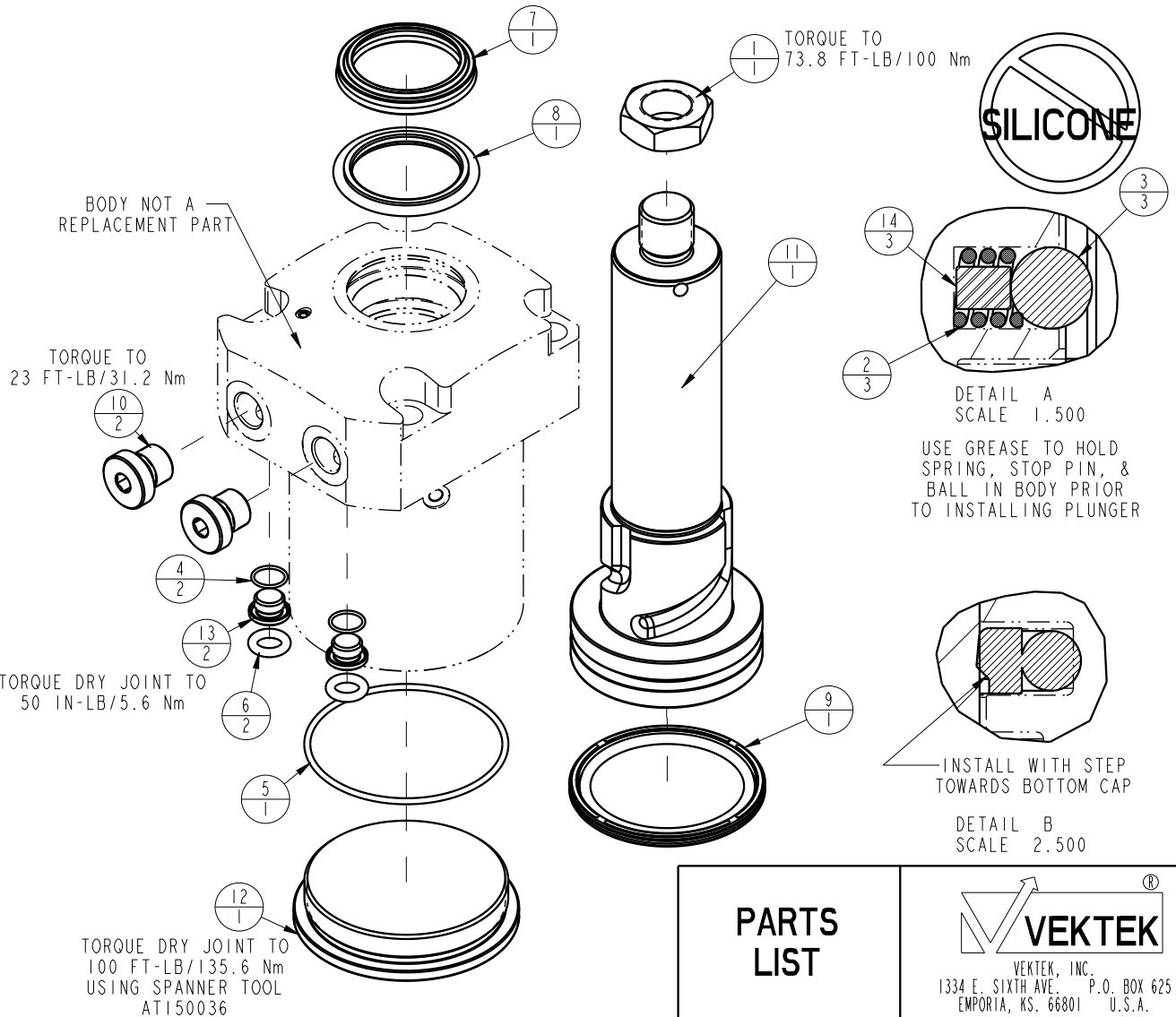

| | |
|----------------------------------|--|
| PARTS LIST | |
| | VEKTEK, INC. 1334 E. SIXTH AVE. P.O. BOX 625 EMPORIA, KS. 66801 U.S.A. |
| ASSEMBLIES AFFECTED L1406300R | PARTS LIST, ASSY, SC, TF, 7MPα, 63B, RH |
| DATE: 7-17-13 | SIZE A LPL1409 |
| FORM FEG035_PL_ASIZE, REV. B | |

| | | | | |
|---------------|------------------------|--|------------|----------|
| B | 3273 | RELEASE | JDW | 08/15/18 |
| REV | IN ACCORDANCE WITH ECN | EFFECTIVE DATE | REVISED BY | DATE |
| DRW BY: | OMITCHELL | DRAWING STATUS: Released | | |
| DATE: 7-17-13 | | PRODUCTION APPROVED FOR RELEASED STATUS ONLY | | |