

NO	QTY	PART NO	DESCRIPTION	SEAL KIT
1	2	21500320	SCREW, SET, CUP PT, M8 X 1.25 X 14	
2	4	23050023	RING, RTNG, EXT, 0.500	X
3	2	23050038	RING, RTNG, EXT, 0.469	X
4	2	39051080	O-RING, (10mm X 1)	X
5	1	39051085	O-RING, (63mm X 2)	X
6	2	39051088	O-RING, (8mm X 3)	X
7	1	39053044	SEAL, WIPER, SNAP IN, WED, 26, 94A, AU	X
8	1	39056004	SEAL, STEP, ROD, 26	X
9	1	39056015	SEAL, CAP, PISTON, 63, 94A, AU	X
10	2	43068006	PLUG, PORT, HOLLOW HEX, G1/4	
11	1	81400155	CAP, LC/SC, 7MPa, 63B	
12	2	81400201	PLUG, MANIFOLD, 7MPa, M10	
13	1	81600144	PLUNGER, LC, 7MPa, 63B	
14	2	81600149	LINK, LC, 7MPa, 63B	
15	2	81600154	PIN, LINK, LC, 7MPa, 63B	
16	1	81600159	PIN, PLUNGER, LC, 7MPa, 63B	
N/A	N/A	L6016630	KIT, SEAL, LC, 7MPa, 63B	NOTED

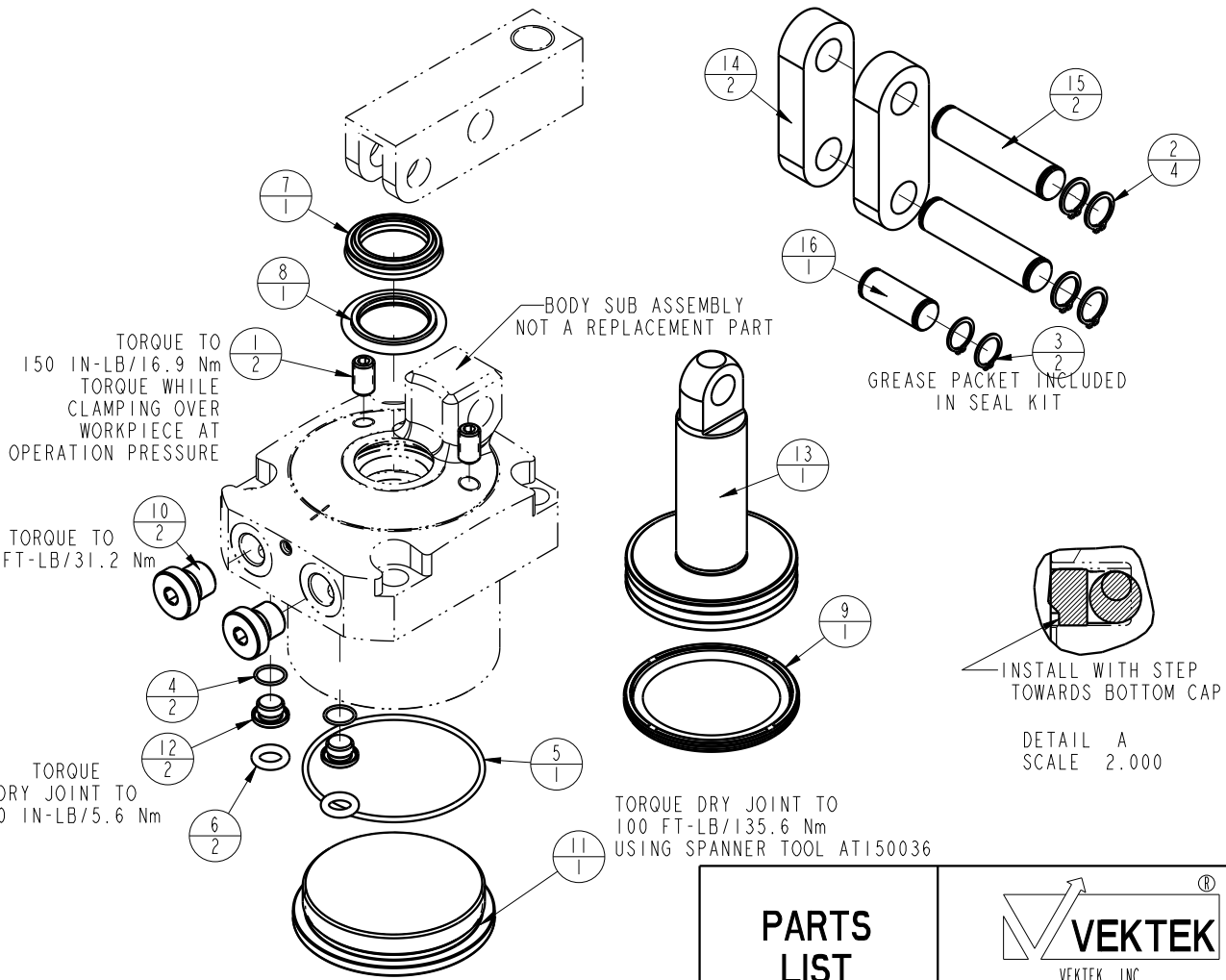

PARTS LIST						
	VEKTEK, INC. 1334 E. SIXTH AVE. P.O. BOX 625 EMPORIA, KS. 66801 U.S.A.					
	ASSEMBLIES AFFECTED	PARTS LIST, ASSY, LC, 7MPa, 63B				
REV	IN ACCORDANCE WITH ECN	EFFECTIVE DATE	REVISED BY	DATE	ROTARY LUG	
DATE: 7-16-13	DRAWING STATUS: <b>Released</b>				SIZE A	LPL1604
	PRODUCTION APPROVED FOR RELEASED STATUS ONLY				REV C	