

LUBRICATE ALL SEALS WITH CLEAN HYDRAULIC OIL PRIOR TO ASSEMBLY  
DO NOT USE SILICONE BASED LUBRICANTS

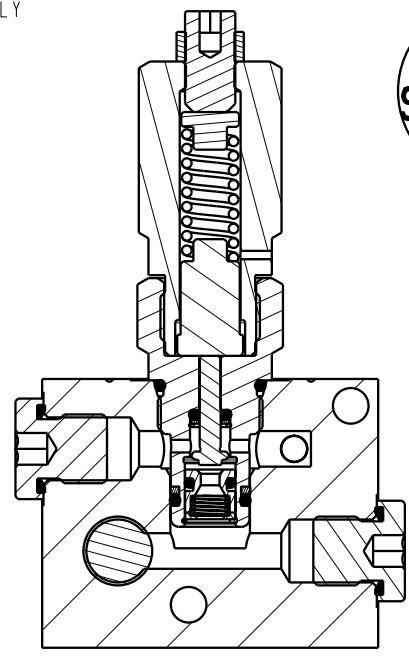

NO	QTY	PART NO	DESCRIPTION	STD SEAL KIT	SPRING KIT
1	1	21420019	NUT, HEX, 3/8-64, SST		
2	1	21430022	RETAINER, .170 X .290 X .030		
3	1	21440035	SCREW, SET, FP, 3/8-64 x 3/4, SST		
4	1	23002015	RETAINING RING, BASIC INTERNAL	X	X
5	1	23010006	RETAINING RING, C, EXT	X	
6	1	23355009	SPRING, COMP, .270 X .022 X .340, 6.1, SST	X	X
7	1	23355010	SPRING, COMP, .420 X .072 X 1.00, 121, SST		X
8	1	39000009	O-RING, (-008), .176x.070, 70 NBR	X	
9	1	39000063	O-RING, (-010), .239x.070, 75 FKM	X	
10	1	39000064	O-RING, 17mm x 2,90 NBR	X	
11	1	39000065	O-RING, 11mm x 2,70 NBR	X	
12	1	39010062	BU RING, 11mmx2, PFTE, CUT	X	
13	1	39010063	SEAL, ROD	X	
14	2	39051079	O-RING, 6mm X 1mm, 90, NBR	X	
15	2	39051087	O-RING, 4mm X 3mm, 90, NBR	X	
16	3	43068006	PLUG, PORT, HOLLOW HEX, G1/4		
17	2	81400200	PLUG, MANIFOLD, 7MPa, M6		
18	1	87044005	GUIDE, SPRING, UPPER, VLV, SEQ, 7MPa		
19	1	87044006	PISTON, VLV, SEQ, 7MPa		
20	1	87044007	PLUNGER, VLV, SEQ, 7MPa		
21	1	87044008	GUIDE, SPRING, LOWER, VLV, SEQ, 7MPa		
22	1	87044009	RETAINER, VLV, SEQ, 7MPa		
23	1	87044010	MANIFOLD, VLV, SEQ, LP		
N/A	N/A	L6070040	KIT, SEAL, VLV, SEQ, 7MPa	NOTED	N/A
N/A	N/A	L6170040	KIT, SPRING, VLV, SEQ, 7MPa	N/A	NOTED

**PARTS LIST**

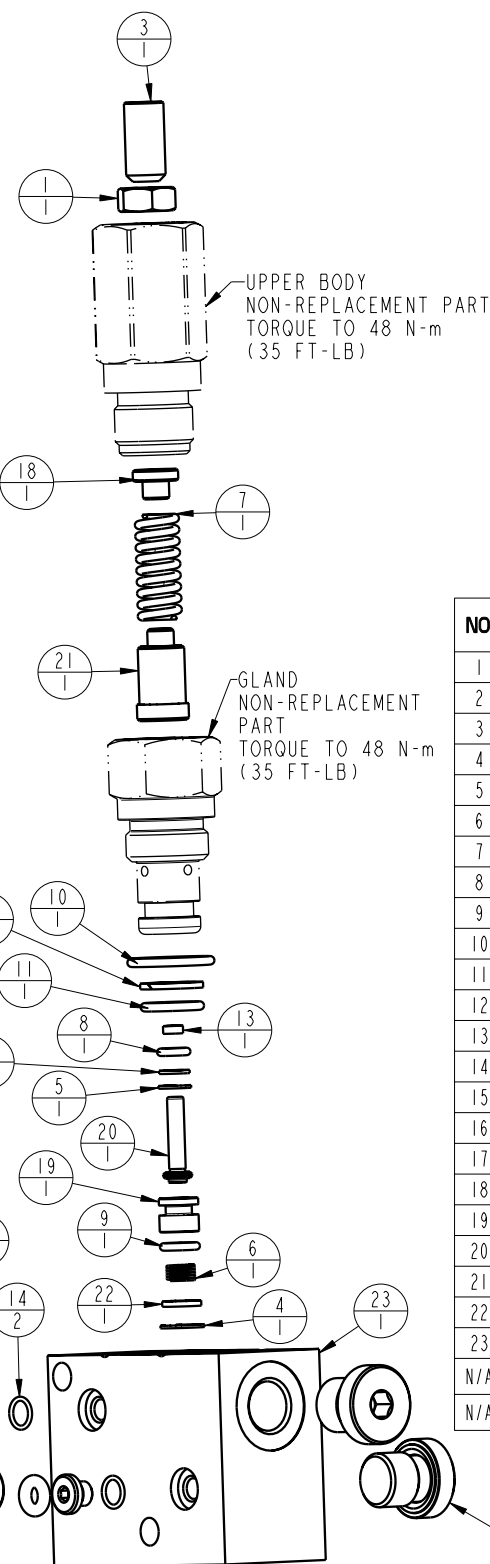

VEKTEK, INC.  
1334 E. SIXTH AVE. P.O. BOX 625  
EMPORIA, KS. 66801 U.S.A.

B	2568	RELEASE	JDW	09/12/13
REV	IN ACCORDANCE WITH ECN	EFFECTIVE DATE	REVISED BY	DATE
DRW BY:	DKC	<b>DRAWING STATUS: Released</b>		
DATE:	3-20-13	PRODUCTION APPROVED FOR RELEASED STATUS ONLY		

ASSEMBLIES AFFECTED  
L7041200

PARTS LIST, ASSY, VLV, SEQ, MM, 7MPa

SIZE A  
LPL7401

REV B