

LUBRICATE ALL SEALS WITH CLEAN HYDRAULIC OIL PRIOR TO ASSEMBLY.
DO NOT USE SILICONE BASED LUBRICANTS.

**THIS IS A TWO PAGE PARTS LIST
THIS PAGE APPLIES TO
ASSEMBLIES AFTER 8-1-2009**

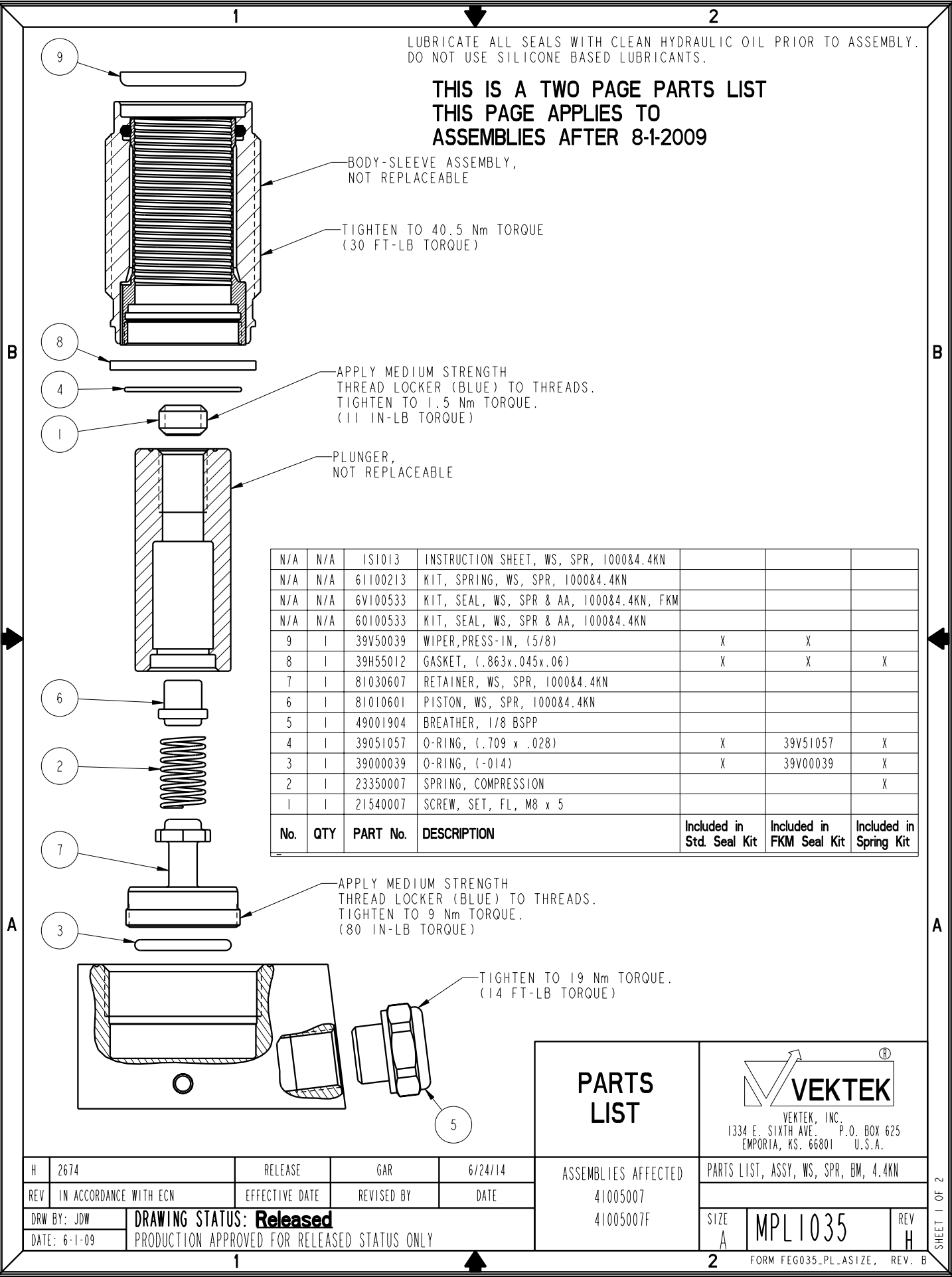

BODY-SLEEVE ASSEMBLY,
NOT REPLACEABLE

TIGHTEN TO 40.5 Nm TORQUE
(30 FT-LB TORQUE)

APPLY MEDIUM STRENGTH
THREAD LOCKER (BLUE) TO THREADS.
TIGHTEN TO 1.5 Nm TORQUE.
(11 IN-LB TORQUE)

PLUNGER,
NOT REPLACEABLE

N/A	N/A	IS1013	INSTRUCTION SHEET, WS, SPR, 1000&4.4KN			
N/A	N/A	61100213	KIT, SPRING, WS, SPR, 1000&4.4KN			
N/A	N/A	6V100533	KIT, SEAL, WS, SPR & AA, 1000&4.4KN, FKM			
N/A	N/A	60100533	KIT, SEAL, WS, SPR & AA, 1000&4.4KN			
9	1	39V50039	WIPER,PRESS-IN, (5/8)	X	X	
8	1	39H55012	GASKET, (.863x.045x.06)	X	X	X
7	1	81030607	RETAINER, WS, SPR, 1000&4.4KN			
6	1	81010601	PISTON, WS, SPR, 1000&4.4KN			
5	1	49001904	BREATHER, 1/8 BSPP			
4	1	39051057	O-RING, (.709 x .028)	X	39V51057	X
3	1	39000039	O-RING, (-014)	X	39V00039	X
2	1	23350007	SPRING, COMPRESSION			X
1	1	21540007	SCREW, SET, FL, M8 x 5			
No.	QTY	PART No.	DESCRIPTION	Included in Std. Seal Kit	Included in FKM Seal Kit	Included in Spring Kit

APPLY MEDIUM STRENGTH
THREAD LOCKER (BLUE) TO THREADS.
TIGHTEN TO 9 Nm TORQUE.
(80 IN-LB TORQUE)

TIGHTEN TO 19 Nm TORQUE.
(14 FT-LB TORQUE)

PARTS LIST



VEKTEK, INC.
1334 E. SIXTH AVE. P.O. BOX 625
EMPORIA, KS. 66801 U.S.A.

ASSEMBLIES AFFECTED

41005007

41005007F

PARTS LIST, ASSY, WS, SPR, BM, 4.4KN

SIZE

A

MPL1035

REV

H

H	2674	RELEASE	GAR	6/24/14
REV	IN ACCORDANCE WITH ECN	EFFECTIVE DATE	REVISED BY	DATE
DRW BY: JDW	DRAWING STATUS: Released			
DATE: 6-1-09	PRODUCTION APPROVED FOR RELEASED STATUS ONLY			

FORM FEG035_PL_ASIZE, REV. B

SHEET 1 OF 2

THIS IS A TWO PAGE PARTS LIST
 THIS PAGE APPLIES TO
 ASSEMBLIES BEFORE 8-1-2009

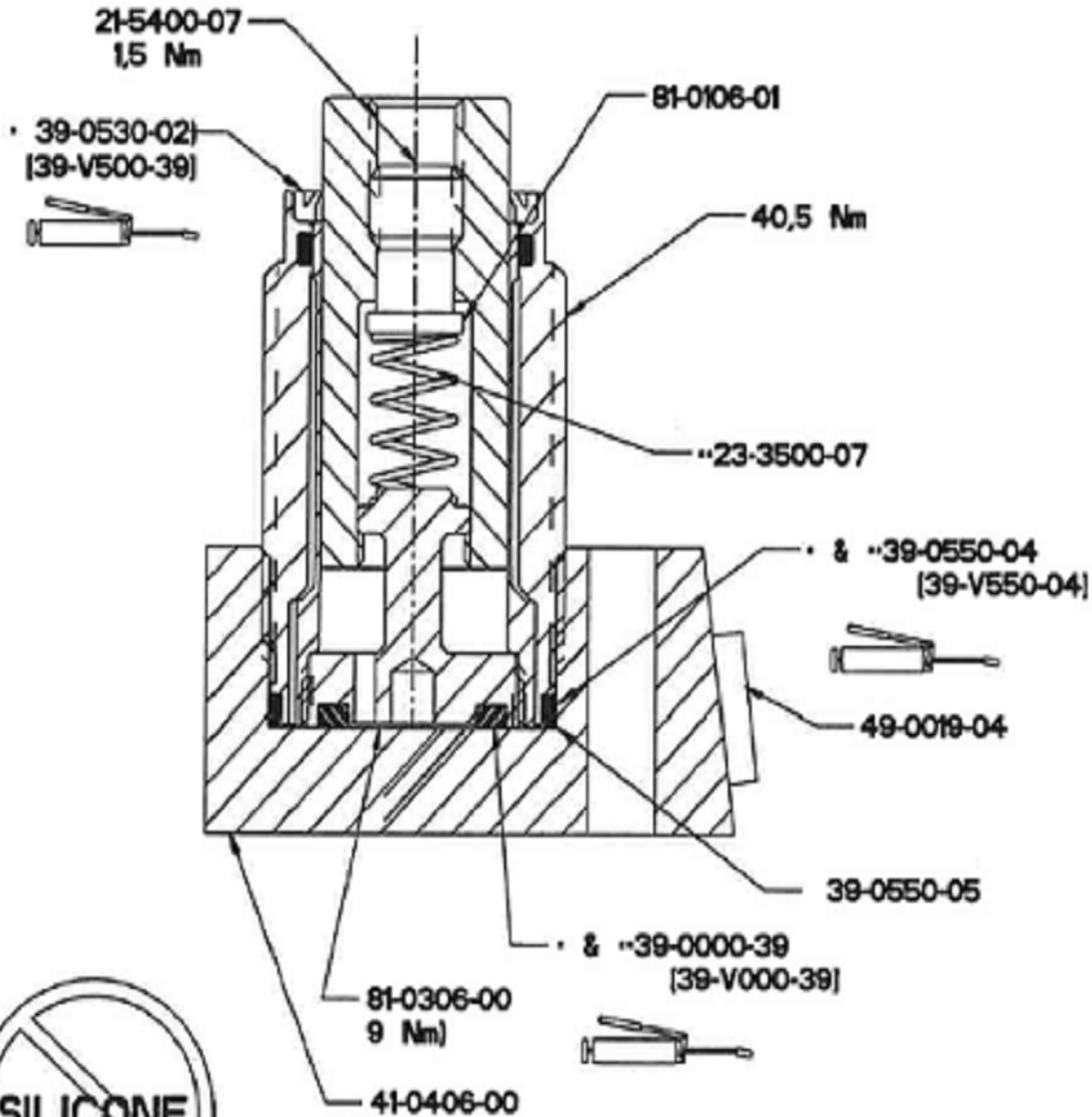

• INCLUDED IN SEAL KIT No. 64-1002-07 / 96891
 [6V-1002-08]

•• INCLUDED IN SPRING KIT No. 61-1004-08

PARTS LIST



VEKTEK, INC.
 1334 E. SIXTH AVE. P.O. BOX 625
 EMPORIA, KS. 66801 U.S.A.

H	2674	RELEASE	GAR	6/24/14
REV	IN ACCORDANCE WITH ECN	EFFECTIVE DATE	REVISED BY	DATE
DRW BY:	DRAWING STATUS: Released			
DATE:	PRODUCTION APPROVED FOR RELEASED STATUS ONLY			

ASSEMBLIES AFFECTED
 41005000

PARTS LIST, ASSY, WS, SPR, BM, 4.4KN

SIZE
 A MPL1035

REV
 H

SHEET 2 OF 2

Vekttek, Inc. 1334 East Sixth Ave. P.O. Box 625 Emporia, Ks. 66801 U.S.A.	Instruction Sheet	IS1013		
		REVISION:	A , I.A.W. ECN2017	
		BY/DATE:	JDW	5-20-09
		APPR/DATE:	JAM	6-1-09
Title: Disassembly/Assembly: 1000 lb & 4.4kN Spring Advance Work Supports				

Read all instructions before disassembly

Refer to the illustration on page three for component numbers and a tool list.

Disassembly

Notice: When disassembling multiple work supports, the plunger and body/sleeve assembly from each work support should be kept together.

1. Clamp work support base (1) in a vise. Cartridge mounted work supports must remain in their fixture for steps two and three.
2. Connect a hydraulic power supply to the work support. Apply hydraulic pressure (approximately 1000 psi) to lock the plunger (2) in place.
3. Remove the set screw (3) from inside the tapped hole of the plunger (2).
4. Release the hydraulic pressure and disconnect the hydraulic line.
5. Remove the work support cartridge from the base (1) or fixture.
Caution- Use a six-point socket only. Other types of wrenches may damage the work support.
6. Unscrew the threaded retainer (6) from the body/sleeve assembly (5) and slide the retainer (6) and the plunger (2) out of the body/sleeve assembly (5).
7. Remove the o-rings (4) (11) and gasket (8).
8. Remove the retainer (6) from the plunger (2) by pushing the retainer (6) away from its seat and tipping it to one side, allowing it to slip out of the plunger (2) cavity.
9. Remove the wiper (9) from the body/sleeve assembly (5). **Caution--Do not damage the inner sleeve of the body/sleeve assembly (5).**
10. Clean all parts thoroughly and set aside to dry.

Vekttek, Inc. 1334 East Sixth Ave. P.O. Box 625 Emporia, Ks. 66801 U.S.A.	Instruction Sheet	IS1013	
		REVISION:	A , I.A.W. ECN2017
		BY/DATE:	JDW 5-20-09
		APPR/DATE:	JAM 6-1-09
Title: Disassembly/Assembly: 1000 lb & 4.4kN Spring Advance Work Supports			

Assembly

1. Lubricate the gasket (8) and o-rings (4) & (11) with clean hydraulic oil (Vekttek 65-0010-01 or equivalent). Apply Loctite primer N® or equivalent to the threads of the retainer (6) and set screw (3) then allow to dry.
2. Press the wiper (9) into the body/sleeve assembly (5), using only enough force to seat the wiper in the counterbore. **Caution: Excess force may cause the inner sleeve to collapse.**
3. Insert the piston (10) into the plunger (2) making certain that it seats against the bottom of the bore in the plunger (2).
4. Insert the spring (7) into the plunger (2) bore.
5. Insert the retainer (6) into the plunger (2) by tipping the retainer (6) to one side and slipping it through the smaller plunger (2) hole, allowing it to seat squarely on the opposite side of the plunger (2) hole. **Note: The retainer (2) should move smoothly up and down within the plunger (2) hole, when enough force is used to overcome the spring pressure.**
6. Place the o-ring (4) into the internal groove in the body/sleeve assembly (5). Apply medium strength Loctite 243® or equivalent to the retainer (6) threads and screw the retainer (6) into the body/sleeve assembly (5). Tighten to the torque specification on the parts list.
7. Place the o-ring (11) on the bottom of the retainer (6) and place the gasket (8) into the bottom of the base (1) or fixture cavity.
8. Screw the body/sleeve assembly (5) into the base (1) or fixture cavity. The body/sleeve assembly (5) will come to a positive stop when it contacts the mating surface in the base (1) or fixture cavity.
9. Tighten the body/sleeve assembly (5) to the base (1) or fixture cavity using the torque specification on the parts list. **Caution- Use a six-point socket only. Other types of wrenches may damage the work support.**
10. Connect the hydraulic power supply to the work support. Apply hydraulic pressure (approximately 1000 psi) to lock the plunger (2) in place.
11. Apply medium strength Loctite 243® or equivalent to the threads of the set screw (3). Thread the set screw (3) into the plunger (2) and tighten to the torque specification on the parts list.
12. Release the pressure and disconnect the hydraulic line.

Vektec, Inc. 1334 East Sixth Ave. P.O. Box 625 Emporia, Ks. 66801 U.S.A.	Instruction Sheet		IS1013		
			REVISION:	A , I.A.W. ECN2017	
			BY/DATE:	JDW	5-20-09
			APPR/DATE:	JAM	6-1-09
Title: Disassembly/Assembly: 1000 lb & 4.4kN Spring Advance Work Supports					

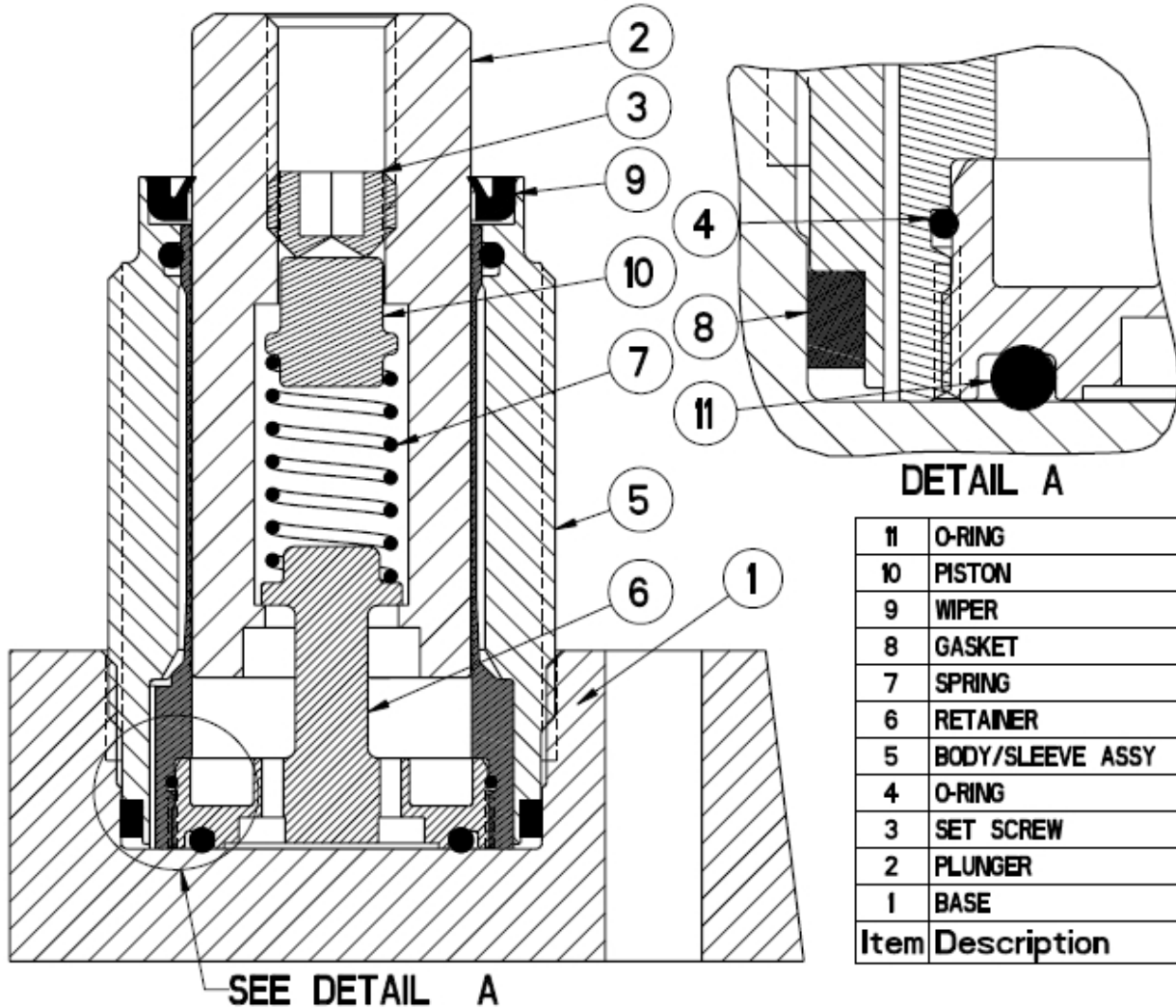

11	O-RING
10	PISTON
9	WIPER
8	GASKET
7	SPRING
6	RETAINER
5	BODY/SLEEVE ASSY
4	O-RING
3	SET SCREW
2	PLUNGER
1	BASE
Item	Description

Model Number	Tool List
10050610 10050611 10050612	5/32 hex key, spanner wrench, 7/8 socket (6 pt)
41005107 41005007 6964F-04-1 6964F-04-2	4mm hex key, spanner wrench, 23mm socket (6 pt)