

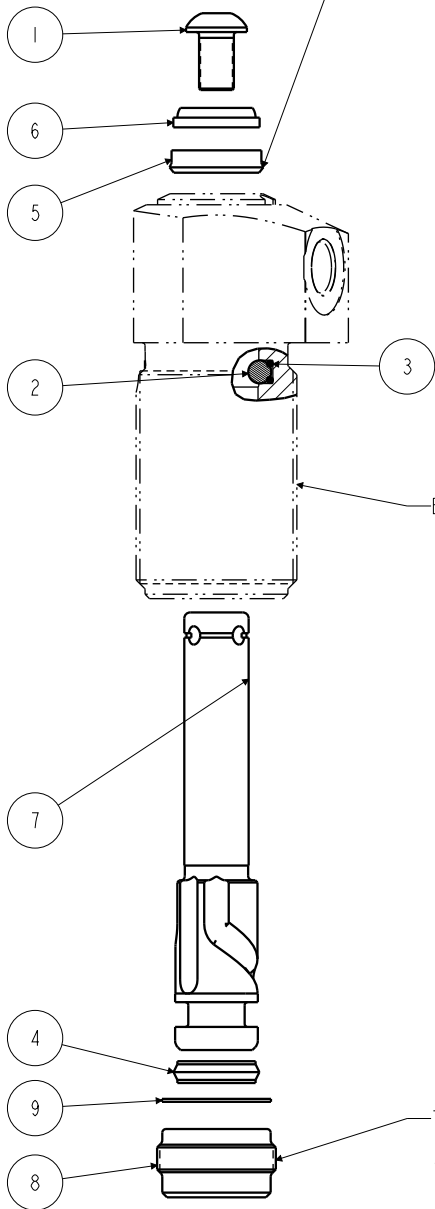

N/A	N/A	6V150205	KIT, SEAL, FKM	N/A	NOTED
N/A	N/A	46000010	KIT, SEAL, STANDARD	NOTED	N/A
9	1	39T55001	GASKET, (-113)	X	X
8	1	81530500	RETAINER, SC, 450		
7	1	47510500	PLUNGER, SC, 2.0 kN		
6	1	39053004	WIPER, SNAP-IN, (7/16)	X	X
5	1	39010038	SEAL, BEVEL, 7/16 x 3/32 x 5/8	X	39052014
4	1	39010037	SEAL, CROWN, 3/8x9/16x5/32	X	39V10037
3	1	39000032	O-RING, (.070 x .040)	X	39051020
2	1	23600014	BALL, STEEL, ALLOY, .156	X	X
1	1	21500008	SCREW, CAP, BTNH, M6 X 10, ALY		
No.	QTY	PART No.	DESCRIPTION	Standard Seal Kit	FKM Seal Kit

Assemble with lip side facing bottom of body



Lubricate all seals with clean hydraulic fluid prior to assembly.  
Do Not Use Silicone Based Lubricants.



<b>PARTS LIST</b>	 <b>VEKTEK</b> VEKTEK, INC. 1334 E. SIXTH AVE. P.O. BOX 625 EMPORIA, KS. 66801 U.S.A.	
	ASSEMBLIES AFFECTED	PARTS LIST, ASSY, SC, TB, 2KN, DA, VersoCam
	41500221 41500222 41500225	SIZE A <b>MPL1511</b> REV K

K	3915	RELEASE	JDW	09/13/19
REV	IN ACCORDANCE WITH ECN	EFFECTIVE DATE	REVISED BY	DATE
DRW BY: BUSH	<b>DRAWING STATUS: Released</b> PRODUCTION APPROVED FOR RELEASED STATUS ONLY			
DATE: 12/19/94				

SHEET 1 OF 1