

N/A	N/A	46100010	KIT, SPRING	N/A	N/A	NOTED
N/A	N/A	6V150106	KIT, SEAL, FKM	N/A	NOTED	N/A
N/A	N/A	46000017	KIT, SEAL, STANDARD	NOTED	N/A	N/A
17	1	39T55001	GASKET, (-113)	X	X	X
16	1	81590501	ROD, SUPPORT, SPRING, SC, 450			X
15	1	81530500	RETAINER, SC, 450			
14	1	49001904	BREATHER, 1/8 BSPP			
13	1	47510500	PLUNGER, SC, 2.0 kN			
12	1	43068004	PLUG, 1/8 BSPP			
11	1	39053004	WIPER, SNAP-IN, (7/16)	X	X	
10	2	39050042	O-RING, (-011)	X	39051025	X
9	1	39010038	SEAL, BEVEL, 7/16 x 3/32 x 5/8	X	39052014	
8	1	39010036	SEAL, BEVEL, 3/8 x 3/32 x 9/16	X	39052010	
7	1	39000032	O-RING, (.070 x .040)	X	39051020	X
6	2	23600014	BALL, STEEL, ALLOY, .156	X	X	X
5	1	23311017	SPRING, COMPRESSION			X
4	1	23310008	SPRING, COMPRESSION			X
3	2	21500200	WASHER			
2	2	21500018	SCREW, CAP, SOCH, M3 X 5, ALY			
1	1	21500008	SCREW, CAP, BTNH, M6 X 10, ALY			
No.	QTY	PART No.	DESCRIPTION	Standard Seal Kit	FKM Seal Kit	Spring Kit

Assemble with lip side facing bottom of body

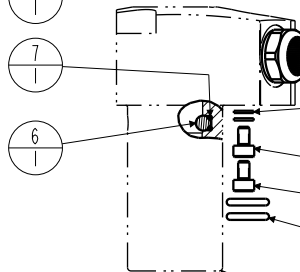
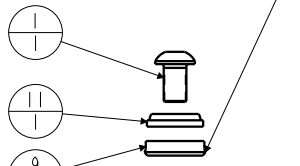

Tighten to 1.2 Nm (11 in-lbs) torque

Body- Not Replaceable

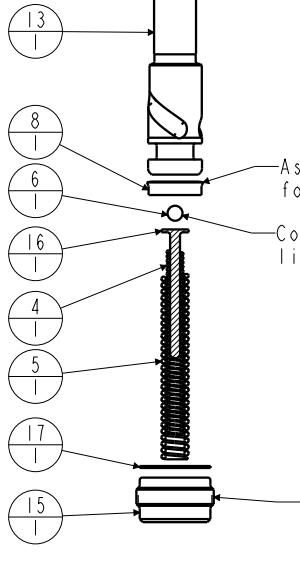

Assemble with lip side facing top of plunger

Coat ball with lithium grease

Tighten to 17.6 Nm (13 ft-lbs) torque

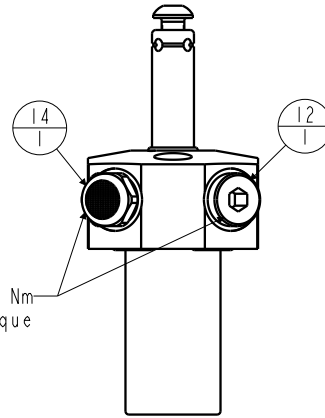

Tighten to 13.6 Nm (10 ft-lbs) torque



Lubricate all seals with clean hydraulic fluid prior to assembly.
Do Not Use Silicone Based Lubricants.

PARTS LIST



VEKTEK, INC.
1334 E. SIXTH AVE. P.O. BOX 625
EMPORIA, KS. 66801 U.S.A.

ASSEMBLIES AFFECTED

41560211
41560212
41560215

PARTS LIST, ASSY, SC, TF, 2KN, SA, VersoCam

SIZE
A

MPL1555

REV
L

SHEET 1 OF 1

FORM FEG035_PL_ASIZE, REV. B

L	3924	RELEASE	JDW	09/17/19
REV	IN ACCORDANCE WITH ECN	EFFECTIVE DATE	REVISED BY	DATE
DRW BY:	COMBES	DRAWING STATUS: Released		
DATE:	03/16/99	PRODUCTION APPROVED FOR RELEASED STATUS ONLY		