

NO	QTY	PART NO	DESCRIPTION	STD SEAL KIT
1	2	21500317	SCREW, SET, CUP PT, M4 X .7 X 8	
2	2	23050032	RING, RTNG, EXT, 0.236	X
3	4	23050033	RING, RTNG, EXT, 0.276	X
4	1	23050053	RETAINING RING, SPIRAL, INTL	X
5	1	23350129	SPRING, COMPRESSION	
6	1	39051088	O-RING, (8mm X 3)	X
7	1	39051149	O-RING, (20mm X 2)	X
8	1	39052065	SEAL, ROD, RSB, 15, 85A, AU	X
9	1	39053041	SEAL, WIPER, SNAP IN, WED, 15, 94A, AU	X
10	1	43061122	PLUG, SOCH, METRIC, M8	
11	1	43068004	PLUG, SOCH, G1/8	
12	2	81600146	LINK, LC, 7MPa, 32B	
13	2	81600151	PIN, LINK, LC, 7MPa, 32B	
14	1	81600156	PIN, PLUNGER, LC, 7MPa, 32B	
15	1	81600261	PLUNGER, LC, TL360, SA, 1000/4.36kN	
16	1	81600271	CAP, LC, TL360, 1000/4.36kN	
N/A	N/A	60160301	KIT, SEAL, ASSY, LC, TL360, SA, 4.36kN	NOTED

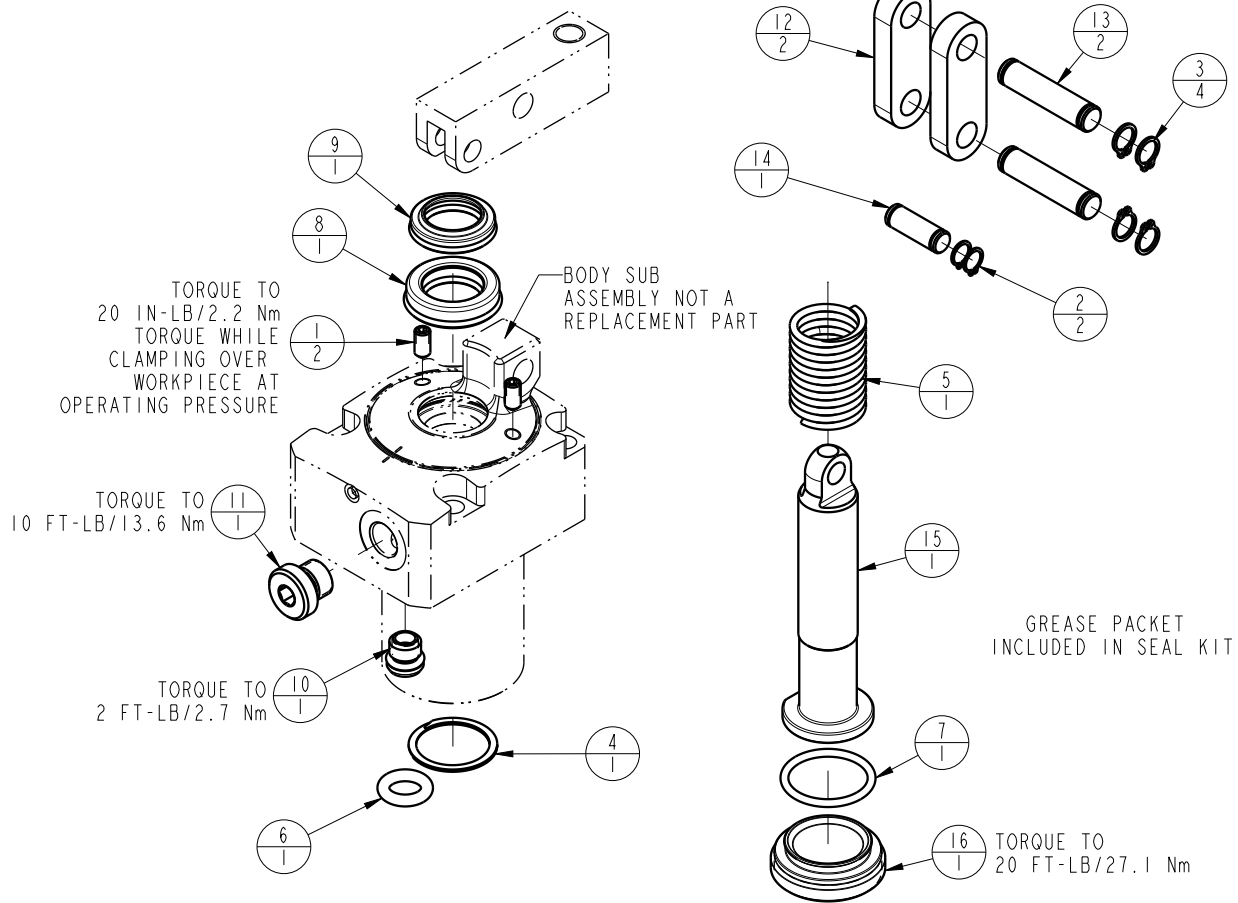

PARTS LIST	
	VEKTEK, INC. 1334 E. SIXTH AVE. P.O. BOX 625 EMPORIA, KS. 66801 U.S.A.
ASSEMBLIES AFFECTED 41-6115-00	PARTS LIST, ASSY, LC, TL360, SA, 4.36kN ROTARY LUG
SIZE A	MPL1615
	REV A

A	3076	RELEASE	BCD	08/22/16
REV	IN ACCORDANCE WITH ECN	EFFECTIVE DATE	REVISED BY	DATE
DRW BY:	BCD	DRAWING STATUS: Released PRODUCTION APPROVED FOR RELEASED STATUS ONLY		
DATE:	07/20/16			