

NO	QTY	PART NO	DESCRIPTION	STD SEAL KIT
1	2	21500317	SCREW, SET, CUP PT, M4 X .7 X 8	
2	2	23050032	RING, RTNG, EXT, 0.236	X
3	4	23050033	RING, RTNG, EXT, 0.276	X
4	1	23050050	RETAINING RING, SPIRAL, INTL	X
5	2	39051088	O-RING, (8mm X 3)	X
6	1	39051149	O-RING, (20mm X 2)	X
7	1	39052059	SEAL, ROD, RSD, 12, 85A, AU	X
8	1	39053040	SEAL, WIPER, SNAP IN, WED, 12, 94A, AU	X
9	1	39056031	SEAL, CAP, PISTON, 15, 94A, AU	X
10	2	43061122	PLUG, SOCH, METRIC, M8	
11	2	43068004	PLUG, SOCH, G1/8	
12	2	81600146	LINK, LC, 7MPa, 32B	
13	2	81600151	PIN, LINK, LC, 7MPa, 32B	
14	1	81600156	PIN, PLUNGER, LC, 7MPa, 32B	
15	1	81600251	PLUNGER, LC, TL360, DA, 1000/4.36kN	
16	1	81600271	CAP, LC, TL360, 1000/4.36kN	
N/A	N/A	60160501	KIT, SEAL, ASSY, LC, TL360, DA, 4.36kN	NOTED

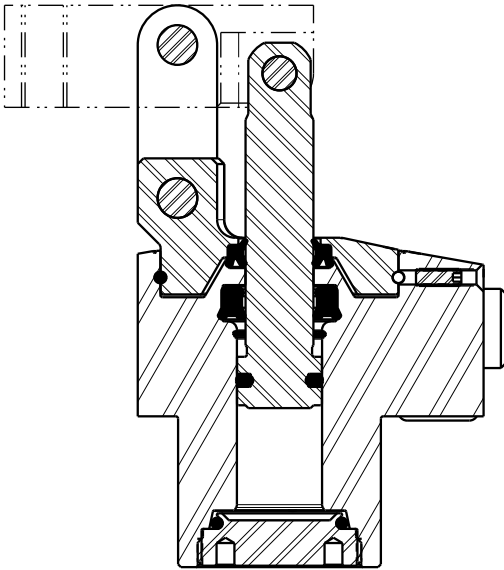

TORQUE TO
20 IN-LB/2.2 Nm
TORQUE WHILE
CLAMPING OVER
WORKPIECE AT
OPERATING PRESSURE

TORQUE TO
10 FT-LB/13.6 Nm

TORQUE TO
2 FT-LB/2.7 Nm

BODY SUB ASSEMBLY
NOT A REPLACEMENT PART

GREASE PACKET INCLUDED
IN SEAL KIT

TORQUE TO
20 FT-LB/27.1 Nm

PARTS LIST



VEKTEK, INC.
1334 E. SIXTH AVE. P.O. BOX 625
EMPORIA, KS. 66801 U.S.A.

ASSEMBLIES AFFECTED
41-6215-00

PARTS LIST, ASSY, LC, TL360, DA, 4.36kN

ROTARY LUG

SIZE
A

MPL1620

REV
A

FORM FEG035_PL_ASIZE, REV. B

A	3076	RELEASE	BCD	08/22/16
REV	IN ACCORDANCE WITH ECN	EFFECTIVE DATE	REVISED BY	DATE
DRW BY:	BCD	DRAWING STATUS: Released		
DATE:	07-15-16	PRODUCTION APPROVED FOR RELEASED STATUS ONLY		

SHEET 1 OF 1