

LUBRICATE ALL SEALS WITH CLEAN HYDRAULIC OIL PRIOR TO ASSEMBLY.
DO NOT USE SILICONE BASED LUBRICANTS.

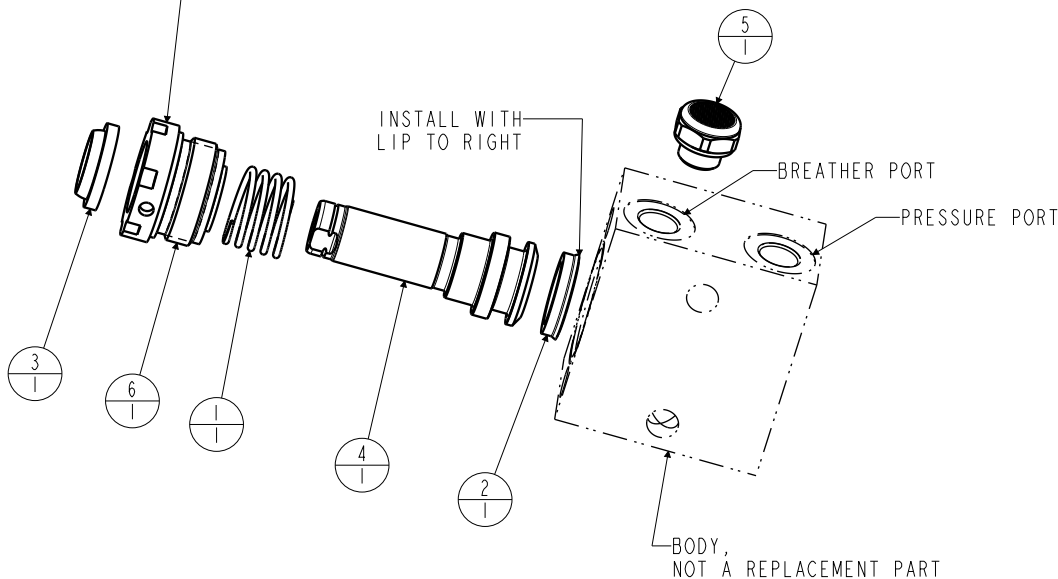

TIGHTEN TO 75 Nm TORQUE (55 FT-LBS)
USE VEKTEK TORQUE TOOL
NEW STYLE TORQUE TOOL AT200081, 6 POINTED TOOL (CIRCA 2018)
OLD STYLE TORQUE TOOL AT200080, 2 POINTED SPANNER HOLE TOOL



No.	QTY	PART No.	DESCRIPTION	Standard Seal Kit	FKM Seal Kit	Spring Kit
N/A	N/A	46100025	KIT, SPRING	N/A	N/A	NOTED
N/A	N/A	6V201108	KIT, SEAL, FKM	N/A	NOTED	N/A
N/A	N/A	46000035	KIT, SEAL, STANDARD	NOTED	N/A	N/A
6	1	82030802	GLAND, CYL, BB, DA, 2200			
5	1	49001904	BREATHER, 1/8 BSPP			
4	1	48010802	PISTON, CYL, BB, 10.1KN, 6.5 STRK			
3	1	39012011	WIPER, SNAP-IN, (1/2)	X	X	
2	1	39010013	SEAL, BEVEL, 9/16 X 3/32 X 3/4	X	39012000	
1	1	23313007	SPRING, COMPRESSION			X

PARTS LIST



VEKTEK, INC.
1334 E. SIXTH AVE. P.O. BOX 625
EMPORIA, KS. 66801 U.S.A.

ASSEMBLIES AFFECTED
42011000

PARTS LIST, ASSY, CYL, BB, 10,1KN, 6,5 STRK, SA

SIZE A
MPL2043

REV H

SHEET 1 OF 1

H	4249	RELEASE	JDW	08/03/20
REV	IN ACCORDANCE WITH ECN	EFFECTIVE DATE	REVISED BY	DATE
DRW BY:	BUSH	DRAWING STATUS: Released		
DATE:	12/15/94	PRODUCTION APPROVED FOR RELEASED STATUS ONLY		