

LUBRICATE ALL SEALS WITH CLEAN HYDRAULIC OIL PRIOR TO ASSEMBLY. DO NOT USE SILICONE BASED LUBRICANTS.

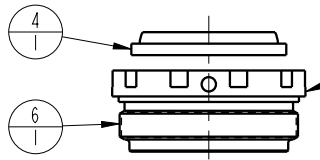

TIGHTEN TO 75 Nm TORQUE ( 55 FT-LBS )  
 USE VEKTEK TORQUE TOOL  
 NEW STYLE TORQUE TOOL AT200151, 10 POINTED TOOL (CIRCA 2018)  
 OLD STYLE TORQUE TOOL AT200150, 2 POINTED SPANNER HOLE TOOL

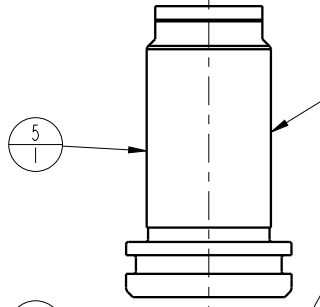

PISTON KIT INCLUDES PISTON AND RETAINING RING 23050013

INSTALL WITH LIPS DOWN

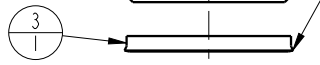

SPRING PAK  
 REMOVAL - INSERT 1/8" INTERNAL HEX WRENCH THRU BODY PORT INTO SPRING PAK RETAINER AND ROTATE CLOCKWISE AS VIEWED FROM BOTTOM.  
 (REINSTALL- REVERSE ABOVE PROCEDURE)



SPRING KIT 41600024  
 INCLUDES  
 SPRING PAC 92060004 AND BOTH RETAINING RINGS 23002003 & 23050013



RETAINING RING, 23002003 (NARROW GROOVE) OLD STYLE

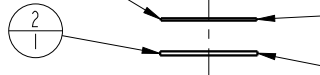

RETAINING RING, 23050013 (WIDE GROOVE) CURRENT STYLE, CIRCA 08/01/2003

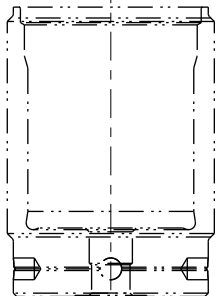

BODY PORT

BODY,

NOT A REPLACEMENT PART

No.	QTY	PART No.	DESCRIPTION	Standard Seal Kit	FKM Seal Kit	Spring Kit
N/A	N/A	46100024	KIT, SPRING	N/A	N/A	NOTED
N/A	N/A	6V200115	KIT, SEAL, FKM	N/A	NOTED	N/A
N/A	N/A	46000030	KIT, SEAL, STANDARD	NOTED	N/A	N/A
7	1	92060004	SPRING PAK,CYL,8800,1.0 STRK			X
6	1	82031501	GLAND, CYL, 8800 & 39.9 KN			
5	1	62201501	Kit,Piston, Ring&Tag,39.9KN,25.5 STRK			
4	1	39050020	WIPER,SNAP-IN, (1-1/8)	X	X	
3	1	39011028	SEAL, BEVEL, 1-5/16 X 3/32 X 1-1/2	X	39012015	
2	1	23050013	SNAP RING, INTERNAL			X
1	1	23002003	SNAP RING, INTERNAL			X

**PARTS LIST**



VEKTEK, INC.  
 1334 E. SIXTH AVE. P.O. BOX 625  
 EMPORIA, KS. 66801 U.S.A.

ASSEMBLIES AFFECTED  
 42001007

PARTS LIST, ASSY,CYL,TB,39.9KN,25.5 STRK,SA

J	4249	RELEASE	JDW	08/10/20
REV	IN ACCORDANCE WITH ECN	EFFECTIVE DATE	REVISED BY	DATE
DRW BY:	BUSH	<b>DRAWING STATUS: Released</b>		
DATE:	12/15/94	PRODUCTION APPROVED FOR RELEASED STATUS ONLY		

SIZE A **MPL2058** REV J

FORM FEG035\_PL\_ASIZE, REV. B

SHEET 1 OF 1