

LUBRICATE ALL SEALS WITH CLEAN HYDRAULIC OIL PRIOR TO ASSEMBLY. DO NOT USE SILICONE BASED LUBRICANTS.



INSTALL WITH LIP TO RIGHT

TIGHTEN TO 75 Nm TORQUE (55 FT-LBS)
 USE VEKTEK TORQUE TOOL
 NEW STYLE TORQUE TOOL AT200151, 10 POINTED TOOL (CIRCA 2018)
 OLD STYLE TORQUE TOOL AT200150, 2 POINTED SPANNER HOLE TOOL

BODY, NOT A REPLACEMENT PART

TIGHTEN TO 24 Nm TORQUE (18 FT-LBS)

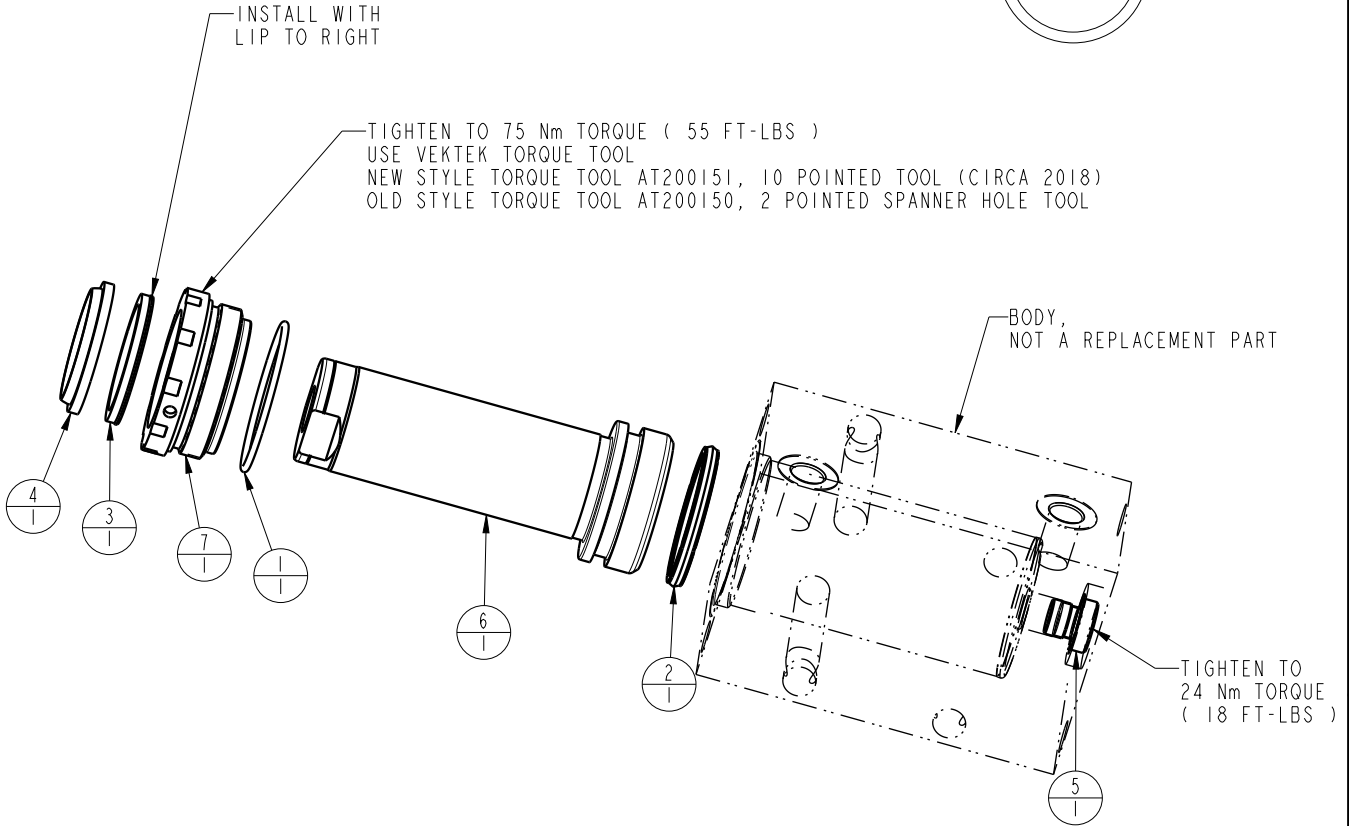

N/A	N/A	6V200214	KIT, SEAL, FKM	N/A	NOTED
N/A	N/A	46000034	KIT, SEAL, STANDARD	NOTED	N/A
7	1	82031501	GLAND, CYL, 8800 & 39.9 KN		
6	1	48011502	PISTON, CYL, 39.9 kN, 51 STRK		
5	1	43068004	PLUG, 1/8 BSPP		
4	1	39050020	WIPER, SNAP-IN, (1-1/8)	X	X
3	1	39011048	SEAL, LL, (1-1/8 X 1/8 X 1/8 X 1-3/8)	X	39012007
2	1	39011031	SEAL, CROWN, 1-5/16x1-1/2x5/32	X	39V11031
1	1	39001013	O-RING, (-029)	X	39012014
No.	QTY	PART No.	DESCRIPTION	Standard Seal Kit	FKM Seal Kit

PARTS LIST



VEKTEK, INC.
 1334 E. SIXTH AVE. P.O. BOX 625
 EMPORIA, KS. 66801 U.S.A.

ASSEMBLIES AFFECTED
 42012007

PARTS LIST, ASSY, CYL, BB, 39.9kN, 51 STRK, DA

SIZE
 A MPL2065

REV
 K

SHEET 1 OF 1

K	4249	RELEASE	JDW	08/13/20
REV	IN ACCORDANCE WITH ECN	EFFECTIVE DATE	REVISED BY	DATE
DRW BY:	BUSH	DRAWING STATUS: Released		
DATE:	12/15/94	PRODUCTION APPROVED FOR RELEASED STATUS ONLY		

FORM FEG035_PL_ASIZE, REV. B