

LUBRICATE ALL SEALS WITH CLEAN HYDRAULIC OIL PRIOR TO ASSEMBLY. DO NOT USE SILICONE BASED LUBRICANTS.

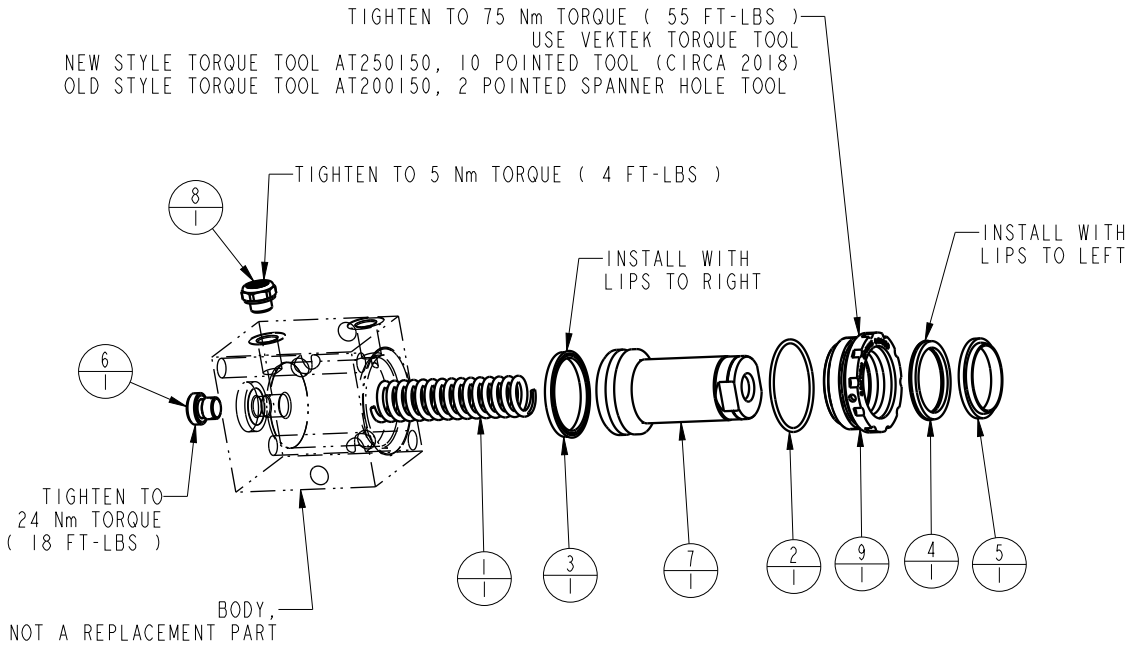

N/A	N/A	46100028	KIT, SPRING	N/A	N/A	NOTED
N/A	N/A	6V201115	KIT, SEAL, FKM	N/A	NOTED	N/A
N/A	N/A	46000037	KIT, SEAL, STANDARD	NOTED	N/A	N/A
9	1	82031501	GLAND, CYL, 8800 & 39.9 KN			
8	1	49001904	BREATHER, 1/8 BSPP			
7	1	48011501	PISTON, CYL, 39.9 kN, 25.5 STRK			
6	1	43068004	PLUG, SOCH, G1/8			
5	1	39050020	WIPER, SNAP-IN, (1-1/8)	X	X	
4	1	39011048	SEAL, LL, (1-1/8 X 1/8 X 1/8 X 1-3/8)	X	39012007	
3	1	39011028	SEAL, BEVEL, 1-5/16 X 3/32 X 1-1/2	X	39012015	
2	1	39001013	O-RING, (-029)	X	39012014	
1	1	23313019	SPRING, COMPRESSION			X
No.	QTY	PART No.	DESCRIPTION	Standard Seal Kit	FKM Seal Kit	Spring Kit

### PARTS LIST



VEKTEK, INC.  
1334 E. SIXTH AVE. P.O. BOX 625  
EMPORIA, KS. 66801 U.S.A.

H	4258	RELEASE	JDW	08/15/20
REV	IN ACCORDANCE WITH ECN	EFFECTIVE DATE	REVISED BY	DATE
DRW BY:	BUSH	<b>DRAWING STATUS: Released</b>		
DATE:	12/15/94	PRODUCTION APPROVED FOR RELEASED STATUS ONLY		

ASSEMBLIES AFFECTED  
42511151

PARTS LIST, ASSY, CYL, PULL, BB, 17.5KN, 25.5 STRK	
SIZE A	MPL2068
REV H	

FORM FEG035\_PL\_ASIZE, REV. B

SHEET 1 OF 1