

APPLY LUBRICANT TO ALL SEALS  
PRIOR TO INSTALLATION.  
DO NOT USE SILICONE TYPE LUBRICANTS.  
FOR PROPER ARM MOUNTING SEE IS1505.

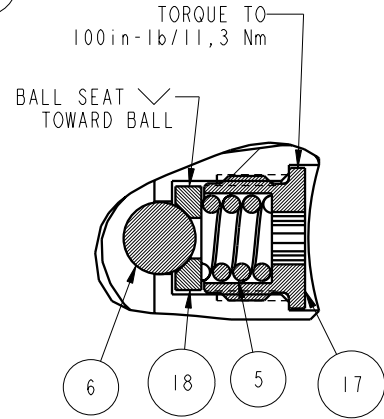

DETAIL A  
SCALE 1.500

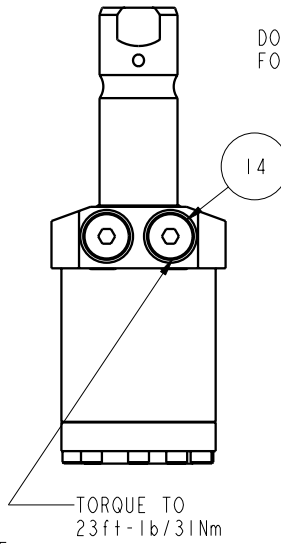
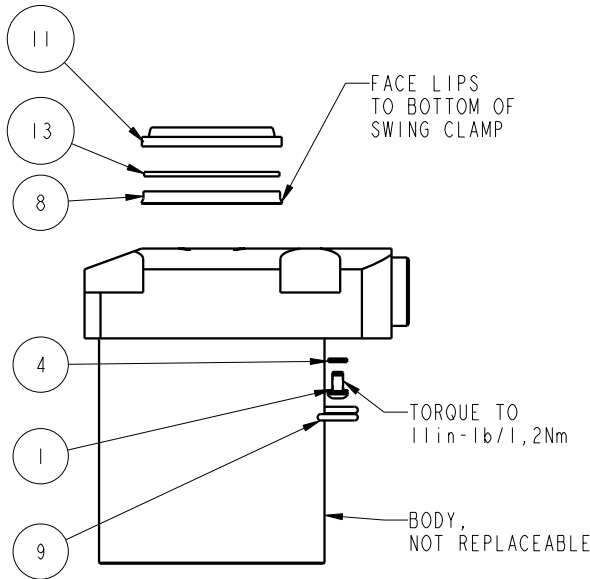
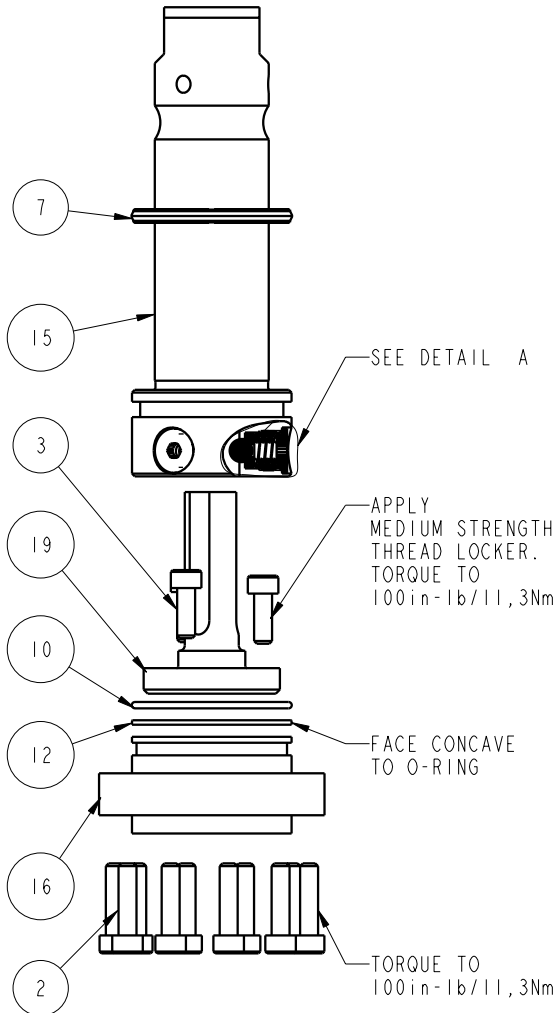

No.	QTY	PART No.	DESCRIPTION	Std. Seal Kit	FKM Seal Kit
N/A	N/A	IS1505	INSTRUCTION SHEET, ARM INSTALLATION		
N/A	N/A	6V711032	SEAL KIT, FKM		
N/A	N/A	60711032	SEAL KIT, STANDARD		
19	1	81591824	CAM, SC, LP, 5000/22KN, STR, TC		
18	3	81532108	SEAT, BALL, SC, LP, TC		
17	3	81532107	RETAINER, SC, LP, TC		
16	1	81531809	CAP, END, SC, LP, 22KN/5000		
15	1	81511811	PLUNGER, SC, LP, 5000/22KN, DA, TC		
14	2	43068006	PLUG, 1/4 BSPP MALE		
13	1	39054008	BU RING, (-218), HYTREL	X	X
12	1	39054007	BU RING, (-030), 90 NBR	X	39054021
11	1	39053005	WIPER, SNAP-IN, (1-1/4), 90 FKM	X	X
10	1	39051042	O-RING, (-030), 1.814x.070, 90 HNBR	X	39V01021
9	2	39050042	O-RING, (-011), .301x.070, 90 AUD	X	39051025
8	1	39011060	SEAL, BEV, INSR, 1.25x.125x1.5, 85 HNBR	X	39052015
7	1	39011056	SEAL, CROWN, 1-9/16x1-3/4x5/32, 90AU	X	39V11056
6	3	23650004	BALL, TUNGSTEN-CARBIDE, 250		
5	3	23350066	SPRING, COMP., .296X.06X.31X.21, 903		
4	2	21500200	WASHER, .124x.207x.024, COPPER		
3	3	21500031	SHCS, M5 x 0.8 x 14, ALY		
2	10	21500022	SHCS, M5 x .8-66 x 20, ALY		
1	2	21500019	SCREW, CAP, BTNH, M3 X 6, ALY		

**PARTS LIST**



VEKTEK, INC.  
1334 E. SIXTH AVE. P.O. BOX 625  
EMPORIA, KS. 66801 U.S.A.

ASSEMBLIES AFFECTED  
41462225

PARTS LIST, ASSY, SC, LP, TC, TF, 22KN, DA, STR

SIZE  
A MPL7146

REV  
B

FORM FEG035\_PL\_ASIZE, REV. A

B	2583	RELEASE	JDW	10/29/13
REV	IN ACCORDANCE WITH ECN	EFFECTIVE DATE	REVISED BY	DATE
DRW BY:	JDW	<b>DRAWING STATUS: Released</b>		
DATE:	6-7-11	PRODUCTION APPROVED FOR RELEASED STATUS ONLY		

SHEET 1 OF 1

