

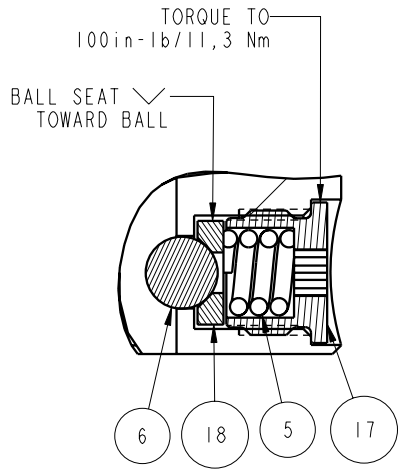

APPLY LUBRICANT TO ALL SEALS PRIOR TO INSTALLATION. DO NOT USE SILICONE TYPE LUBRICANTS. FOR PROPER ARM MOUNTING SEE IS1505.

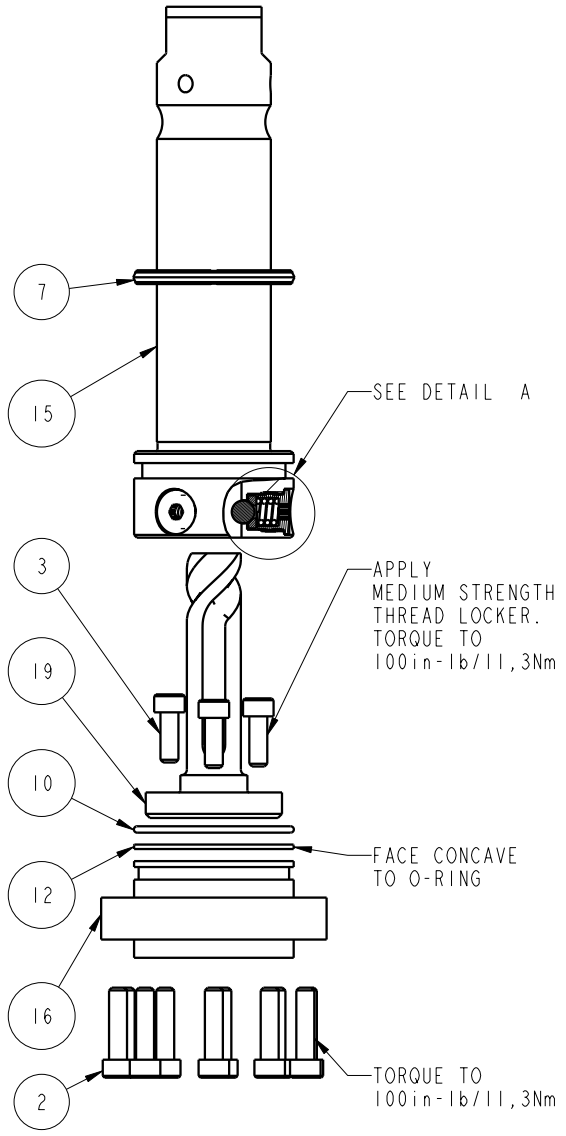

DETAIL A
SCALE 1.500



No.	QTY	PART No.	DESCRIPTION	Std. Seal Kit	FKM Seal Kit
N/A	N/A	IS1505	INSTRUCTION SHEET, ARM INSTALLATION		
N/A	N/A	6V711032	SEAL KIT, FKM		
N/A	N/A	60711032	SEAL KIT, STANDARD		
19	1	81591827	CAM, SC, LP, 22KN, RH, LS, TC		
18	3	81532108	SEAT, BALL, SC, LP, TC		
17	3	81532107	RETAINER, SC, LP, TC		
16	1	81531809	CAP, END, SC, LP, 22KN/5000		
15	1	81511812	PLUNGER, SC, LP, 22KN, DA, LS, TC		
14	2	43068006	PLUG, 1/4 BSPP MALE		
13	1	39054008	BU RING, (-218), HYTREL	X	X
12	1	39054007	BU RING, (-030), 90 NBR	X	39054021
11	1	39053005	WIPER, SNAP-IN, (1-1/4), 90 FKM	X	X
10	1	39051042	O-RING, (-030), 1.814x.070, 90 HNBR	X	39V01021
9	2	39050042	O-RING, (-011), .301x.070, 90 AUD	X	39051025
8	1	39011060	SEAL, BEV, INSR, 1.25x.125x1.5, 85 HNBR	X	39052015
7	1	39011056	SEAL, CROWN, 1-9/16x1-3/4x5/32, 90AU	X	39V11056
6	3	23650004	BALL, TUNGSTEN-CARBIDE, 250		
5	3	23350066	SPRING, COMP., .296X.06X.31X.21, 903		
4	2	21500200	WASHER, .124x.207x.024, COPPER		
3	3	21500031	SHCS, M5 x 0.8 x 14, ALY		
2	10	21500022	SHCS, M5 x .8-6G x 20, ALY		
1	2	21500019	SCREW, CAP, BTNH, M3 X 6, ALY		

PARTS LIST	 VEKTEK, INC. 1334 E. SIXTH AVE. P.O. BOX 625 EMPORIA, KS. 66801 U.S.A.
	ASSEMBLIES AFFECTED 41462223
PARTS LIST, ASSY, SC, LP, TC, TF, 22KN, DA, RH, LS	SIZE A MPL7147
FORM FEG035_PL_ASIZE, REV. A	REV B SHEET 1 OF 1

B	2583	RELEASE	JDW	10/29/13
REV	IN ACCORDANCE WITH ECN	EFFECTIVE DATE	REVISED BY	DATE
DRW BY:	JDW	DRAWING STATUS: Released PRODUCTION APPROVED FOR RELEASED STATUS ONLY		
DATE:	6-7-11			

**READ ALL INSTRUCTIONS BEFORE INSTALLING ARMS
FAILURE TO FOLLOW INSTALLATION INSTRUCTIONS
WILL VOID PRODUCT WARRANTY !**

–Installing or Positioning of Low Profile Swing Clamp Arms–

**NOTE: If the arm is already installed on the plunger,
loosen the cap screw.**

**CAUTION: Never attempt to rotate the arm before loosening
the cap screw. This can damage the plunger rotating mechanism.**

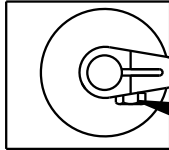

- 1. Rotate the arm to the desired radial position.**
- 2. Tighten to the torque specification listed below.**

MODEL	TORQUE ft-lb	TORQUE N-m
50001b & 22Kn	115 ft-lb	156 N-m
75001b & 33Kn	225 ft-lb	305 N-m

**IT IS RECOMMEND THE CROSS BOLT
BE REPLACED IF THE ARM NEEDS
REMOVED AFTER IT HAS BEEN IN SERVICE.**

CROSS BOLT	CROSS BOLT	CROSS BOLT	CROSS BOLT
5000 & 22KN	5000 & 22KN	7500 & 33KN	7500 & 33KN
SHORT LONG DOUBLE	UPREACH	SHORT LONG DOUBLE	UPREACH
21-5000-24	21-5000-25	21-5000-28	21-5000-25

**Instruction
Sheet**



VEKTEK, INC.
1334 E. SIXTH AVE. P.O. BOX 625
EMPORIA, KS. 66801 U.S.A.

Arm Installation Instruction Sheet

Low Profile Swing Clamps

SIZE A	IS1505	REV C
-----------	--------	----------

FORM FEG041-1S-ASIZE, REV. B

C	2799	RELEASE	JDW	01/29/15
REV	IN ACCORDANCE WITH ECN	EFFECTIVE DATE	REVISED BY	DATE
DRW BY: MES	DRAWING STATUS: Released			
DATE: 08/01/05	PRODUCTION APPROVED FOR RELEASED STATUS ONLY			

SHEET 1 OF 1