

NOTES:

1. INSTALL ROTOR WITH DIMPLE FACING NOTCH IN TOP BODY.
2. INSTALL BALL AND SPRING INTO INDICATED LOCATION.
3. USE EXTREME CAUTION, DO NOT DAMAGE BOTTOM SURFACE OF ROTOR OR TOP SURFACES OF POPPETS.
4. REASSEMBLE UPPER SECTION OF VALVE FIRST
5. PLACE ITEMS 3, 5, 8, 14, AND 20 IN BASE AND FINISH ASSEMBLY.
6. STRETCH O-RING OVER 87114015 AFTER IT HAS BEEN ATTACHED TO THE ROTOR.

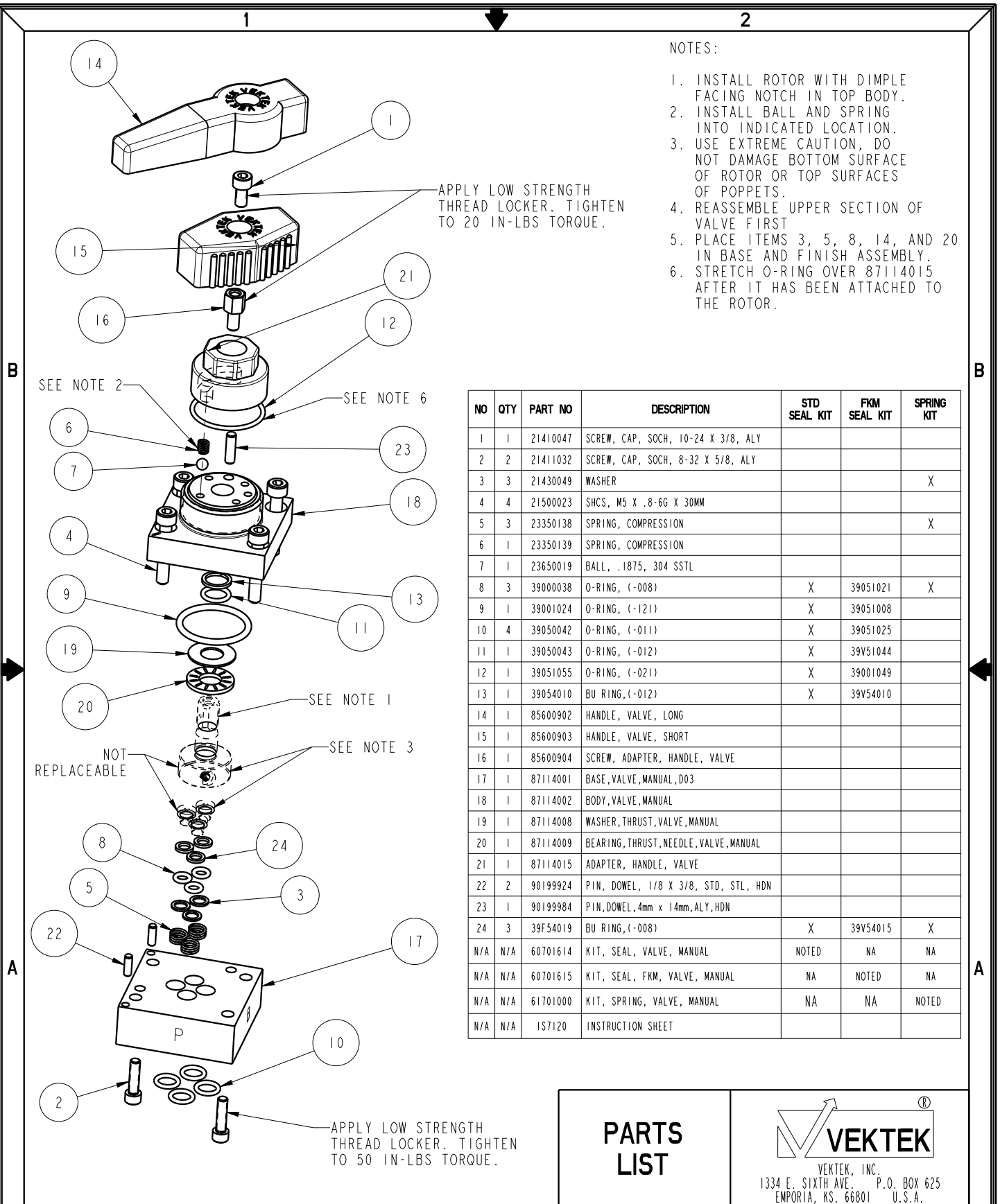

NO	QTY	PART NO	DESCRIPTION	STD SEAL KIT	FKM SEAL KIT	SPRING KIT
1	1	21410047	SCREW, CAP, SOCH, 10-24 X 3/8, ALY			
2	2	21411032	SCREW, CAP, SOCH, 8-32 X 5/8, ALY			
3	3	21430049	WASHER			X
4	4	21500023	SHCS, M5 X .8-6G X 30MM			
5	3	23350138	SPRING, COMPRESSION			X
6	1	23350139	SPRING, COMPRESSION			
7	1	23650019	BALL, .1875, 304 SSTL			
8	3	39000038	O-RING, (-008)	X	39051021	X
9	1	39001024	O-RING, (-121)	X	39051008	
10	4	39050042	O-RING, (-011)	X	39051025	
11	1	39050043	O-RING, (-012)	X	39V51044	
12	1	39051055	O-RING, (-021)	X	39001049	
13	1	39054010	BU RING, (-012)	X	39V54010	
14	1	85600902	HANDLE, VALVE, LONG			
15	1	85600903	HANDLE, VALVE, SHORT			
16	1	85600904	SCREW, ADAPTER, HANDLE, VALVE			
17	1	87114001	BASE, VALVE, MANUAL, D03			
18	1	87114002	BODY, VALVE, MANUAL			
19	1	87114008	WASHER, THRUST, VALVE, MANUAL			
20	1	87114009	BEARING, THRUST, NEEDLE, VALVE, MANUAL			
21	1	87114015	ADAPTER, HANDLE, VALVE			
22	2	90199924	PIN, DOWEL, 1/8 X 3/8, STD, STL, HDN			
23	1	90199984	PIN, DOWEL, 4mm x 14mm, ALY, HDN			
24	3	39F54019	BU RING, (-008)	X	39V54015	X
N/A	N/A	60701614	KIT, SEAL, VALVE, MANUAL	NOTED	NA	NA
N/A	N/A	60701615	KIT, SEAL, FKM, VALVE, MANUAL	NA	NOTED	NA
N/A	N/A	61701000	KIT, SPRING, VALVE, MANUAL	NA	NA	NOTED
N/A	N/A	1S7120	INSTRUCTION SHEET			

PARTS LIST



VEKTEK, INC.
1334 E. SIXTH AVE. P.O. BOX 625
EMPORIA, KS. 66801 U.S.A.

ASSEMBLIES AFFECTED
47-1142-21

PARTS LIST, ASSY, VALVE, MANUAL, CETOP 3, 3/2

SIZE A MPL7184

REV C

C	3892	RELEASE	ALS	08/08/19
REV	IN ACCORDANCE WITH ECN	EFFECTIVE DATE	REVISED BY	DATE
DRW BY:	ALS	DRAWING STATUS: Released		
DATE:	03/25/19	PRODUCTION APPROVED FOR RELEASED STATUS ONLY		

1

2

CENTER SCREW



HANDLE

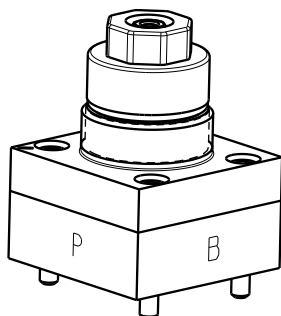
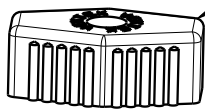

Handle here in position B
A to T

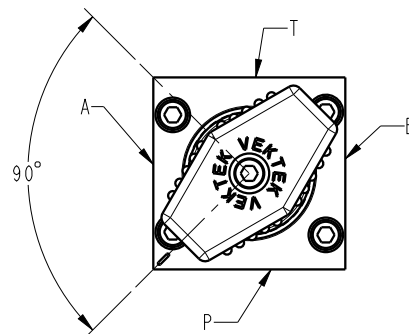

Handle here in position A
P to A

To Reposition Handle:

1. Remove center screw
2. Take off and reposition handle
3. Apply low strength loctite to center screw
4. Torque center screw to 20 in-lbs

B

B

A

A

INSTALLATION INSTRUCTIONS



VEKTEK, INC.
1334 E. SIXTH AVE. P.O. BOX 625
EMPORIA, KS. 66801 U.S.A.

ASSEMBLIES AFFECTED

71-1422-04
47-1142-21

INSTRUCTION SHEET, VALVE, WNL, MANIFOLD, 2/3

SIZE
A

1S7120

REV
A

SHEET 1 OF 1

A	3892	RELEASE	ALS	08/08/19
REV	IN ACCORDANCE WITH ECN	EFFECTIVE DATE	REVISED BY	DATE
DRW BY:	ALS	DRAWING STATUS: Released		
DATE:	08/08/19	PRODUCTION APPROVED FOR RELEASED STATUS ONLY		

1

2

FORM FEG041-1S-ASIZE, REV. B