

APPLY LUBRICANT TO ALL SEALS
PRIOR TO INSTALLATION.
DO NOT USE SILICONE TYPE LUBRICANTS.
FOR PROPER ARM MOUNTING SEE IS1505.

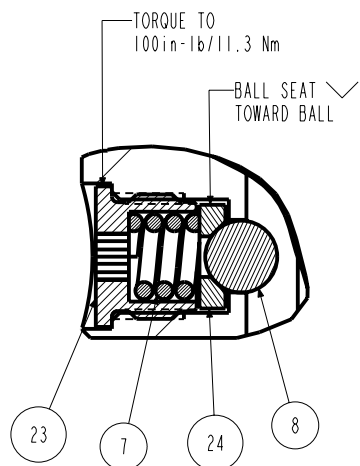

DETAIL A
SCALE 1.500

No.	QTY	PART No.	DESCRIPTION	Std. Seal Kit	FKM Seal Kit
N/A	N/A	IS1505	INSTRUCTION SHEET, ARM INSTALLATION		
N/A	N/A	6V711052	SEAL KIT, FKM		
N/A	N/A	60711052	SEAL KIT, STANDARD		
26	1	39V10029	WIPER, PRESS-IN, (1/4)	X	X
25	1	81591838	CAM, SC, LP, 22KN, LH, LS, TC, PR		
24	3	81532108	SEAT, BALL, SC, LP, TC		
23	3	81532107	RETAINER, SC, LP, TC		
22	1	81531819	CAP, END, SC, LP, 22KN/5000, PR		
21	1	81511822	PLUNGER, SC, LP, 22KN, DA, LS, TC, PR		
20	1	81500042	ROD, ACTUATOR, SC, LP, TF, 22KN, LS		
19	1	81500040	RING, LOCATOR, SC, LP, PR		
18	1	81500039	BUSHING, PLUNGER, PR, SC, LP		
17	2	43068006	PLUG, 1/4 BSPP MALE		
16	1	39054008	BU RING, (-218)	X	X
15	1	39054007	BU RING, (-030)	X	39054021
14	1	39053005	WIPER, SNAP-IN, (1-1/4)	X	X
13	1	39052043	SEAL, LL, (1/4 X 1/8 X 1/8 X 1/2)	X	39V52043
12	1	39051024	O-RING, (-030)	X	39V01021
11	2	39050042	O-RING, (-011)	X	39051025
10	1	39011060	SEAL, BEVEL WHEEL INSERT, 1-1/4 x 1/8 x 1-1/2	X	39052015
9	1	39011056	SEAL, CROWN, 1-9/16 x 1-3/4 x 5/32	X	39V11056
8	3	23650004	BALL, TUNGSTEN-CARBIDE, 250		
7	3	23350066	SPRING, COMPRESSION		
6	2	21500200	WASHER		
5	3	21500031	SHCS, M5 x 0.8 x 14, ALY		
4	10	21500022	SHCS, M5 x .8-6G x 20, ALY		
3	2	21500019	SCREW, CAP, BTNH, M3 X 6, ALY		
2	1	21430022	WASHER		
1	1	21410049	SCREW, CAP, SOCH, 8-32 X 3/8, ALY		

PARTS LIST



VEKTEK, INC.
1334 E. SIXTH AVE. P.O. BOX 625
EMPORIA, KS. 66801 U.S.A.

ASSEMBLIES AFFECTED
41462224PR

PARTS LIST, ASSY, SC, LP, TC, TF, 22KN, DA, LH, LS, PR

SIZE
A **MPL7205**

REV
A

A	2679	RELEASE	JDW	10/29/13
REV	IN ACCORDANCE WITH ECN	EFFECTIVE DATE	REVISED BY	DATE
DRW BY:	JDW	DRAWING STATUS: Released		
DATE:	10/16/13	PRODUCTION APPROVED FOR RELEASED STATUS ONLY		

