

APPLY LUBRICANT TO ALL SEALS PRIOR TO INSTALLATION. DO NOT USE SILICONE TYPE LUBRICANTS. FOR PROPER ARM MOUNTING SEE IS1505.

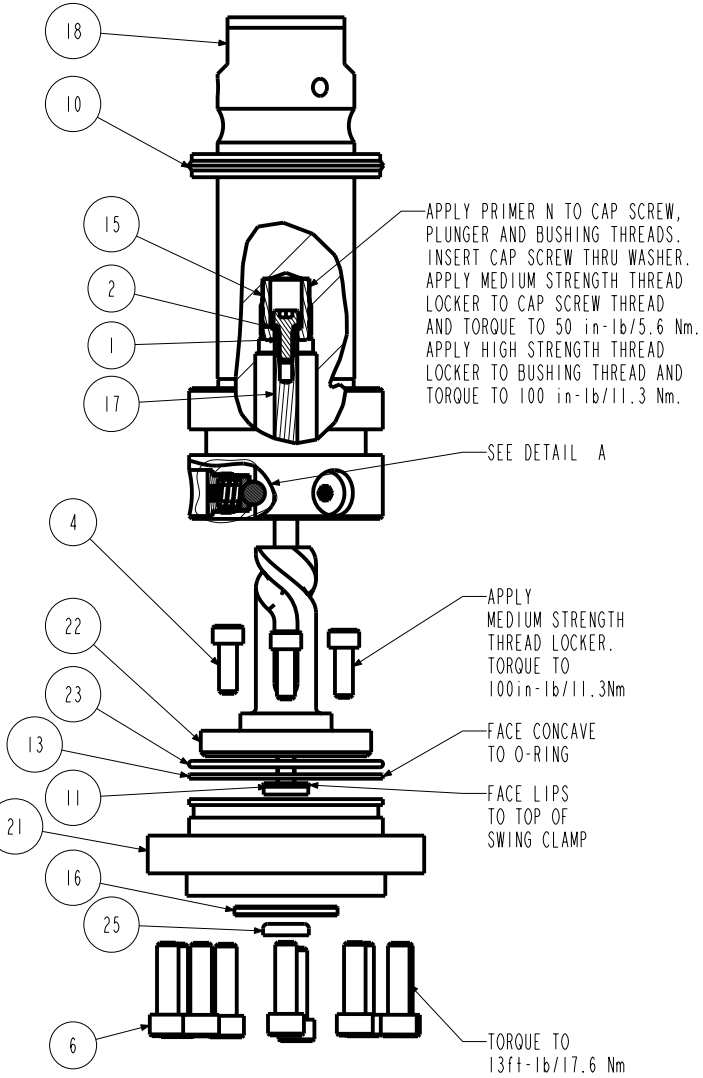
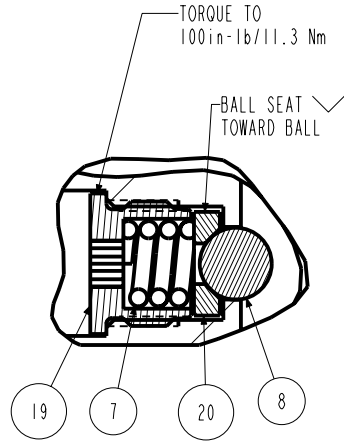

No.	QTY	PART No.	DESCRIPTION	Std. Seal Kit	FKM Seal Kit
N/A	N/A	IS1505	INSTRUCTION SHEET, ARM INSTALLATION		
N/A	N/A	6V711054	SEAL KIT, FKM		
N/A	N/A	60711054	SEAL KIT, STANDARD		
26	1	39V11051	WIPER, PRESS-IN, (1-1/2)	X	X
25	1	39V10029	WIPER, PRESS-IN, (1/4)	X	X
24	1	39H52000	SEAL, U-CUP, 1-1/2 x 1/8 x 1-3/4	X	39V52000
23	1	39H51002	O-RING, (-033)	X	39V51002
22	1	81592132	CAM, SC, LP, 7500/33KN, LH, TC, PR		
21	1	81532115	CAP, END, SC, LP, 33KN/7500, PR		
20	3	81532108	SEAT, BALL, SC, LP, TC		
19	3	81532107	RETAINER, SC, LP, TC		
18	1	81512121	PLUNGER, SC, LP, 7500/33KN, DA, TC, PR		
17	1	81500051	ROD, ACTUATOR, SC, LP, TF, 7500/33KN		
16	1	81500040	RING, LOCATOR, SC, LP, PR		
15	1	81500039	BUSHING, PLUNGER, PR, SC, LP		
14	2	43068006	PLUG, 1/4 BSPP MALE		
13	1	39054017	BU RING, (-033)	X	39054023
12	1	39054016	BU RING, (1.5x.125x.063)	X	X
11	1	39052043	SEAL, LL, (1/4 X 1/8 X 1/8 X 1/2)	X	39V52043
10	1	39052030	SEAL, CROWN, 1-3/4x2-1/8x1/4	X	39V52030
9	2	39050042	O-RING, (-011)	X	39051025
8	3	23650004	BALL, TUNGSTEN-CARBIDE .250		
7	3	23350066	SPRING, COMPRESSION		
6	10	21500304	SHCS, M6 X 1.0-6G X 20MM		
5	2	21500200	WASHER		
4	3	21500031	SHCS, M5 X 0.8 X 14, ALY		
3	2	21500019	SCREW, CAP, BTNH, M3 X 6, ALY		
2	1	21430022	WASHER		
1	1	21410049	SCREW, CAP, SOCH, 8-32 X 3/8, ALY		

A	2679	RELEASE	JDW	12/06/13
REV	IN ACCORDANCE WITH ECN	EFFECTIVE DATE	REVISED BY	DATE
DRW BY:	JDW	DRAWING STATUS: Released		
DATE:	10/16/13	PRODUCTION APPROVED FOR RELEASED STATUS ONLY		

PARTS LIST

ASSEMBLIES AFFECTED
41463322PR

VEKTEK, INC.
1334 E. SIXTH AVE. P.O. BOX 625
EMPORIA, KS. 66801 U.S.A.

SIZE
A

MPL7207

REV
A

FORM FEG035_PL_ASIZE, REV. B

1 **2**

**READ ALL INSTRUCTIONS BEFORE INSTALLING ARMS
FAILURE TO FOLLOW INSTALLATION INSTRUCTIONS
WILL VOID PRODUCT WARRANTY !**

–Installing or Positioning of Low Profile Swing Clamp Arms–

**NOTE: If the arm is already installed on the plunger,
loosen the cap screw.**

**CAUTION: Never attempt to rotate the arm before loosening
the cap screw. This can damage the plunger rotating mechanism.**

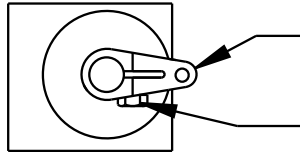

- 1. Rotate the arm to the desired radial position.**
- 2. Tighten to the torque specification listed below.**

MODEL	TORQUE ft-lb	TORQUE N-m
50001b & 22Kn	115 ft-lb	156 N-m
75001b & 33Kn	225 ft-lb	305 N-m

**IT IS RECOMMEND THE CROSS BOLT
BE REPLACED IF THE ARM NEEDS
REMOVED AFTER IT HAS BEEN IN SERVICE.**

CROSS BOLT	CROSS BOLT	CROSS BOLT	CROSS BOLT
5000 & 22KN	5000 & 22KN	7500 & 33KN	7500 & 33KN
SHORT LONG DOUBLE	UPREACH	SHORT LONG DOUBLE	UPREACH
21-5000-24	21-5000-25	21-5000-28	21-5000-25

**Instruction
Sheet**



VEKTEK, INC.
1334 E. SIXTH AVE. P.O. BOX 625
EMPORIA, KS. 66801 U.S.A.

Arm Installation Instruction Sheet

Low Profile Swing Clamps

SIZE A 1S1505 REV C

C	2799	RELEASE	JDW	01/29/15
REV	IN ACCORDANCE WITH ECN	EFFECTIVE DATE	REVISED BY	DATE
DRW BY: MES		DRAWING STATUS: Released		
DATE: 08/01/05		PRODUCTION APPROVED FOR RELEASED STATUS ONLY		

FORM FEG041-1S.AS1ZE, REV. B

SHEET 1 OF 1