

APPLY LUBRICANT TO ALL SEALS PRIOR TO INSTALLATION. DO NOT USE SILICONE TYPE LUBRICANTS. FOR PROPER ARM MOUNTING SEE IS1505.

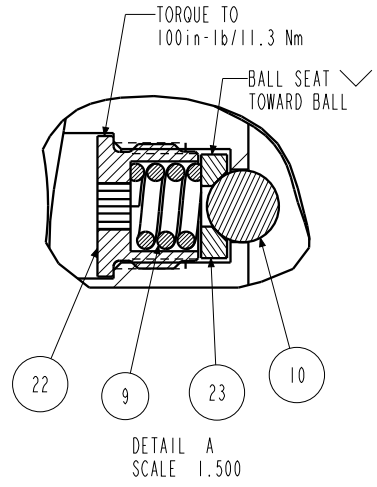

N/A	N/A	IS1505	INSTRUCTION SHEET, ARM INSTALLATION		
N/A	N/A	6V711054	SEAL KIT, FKM		
N/A	N/A	60711054	SEAL KIT, STANDARD		
30	1	39V11051	WIPER, PRESS-IN, (1-1/2)	X	X
29	1	39V10029	WIPER, PRESS-IN, (1/4)	X	X
28	1	39H52000	SEAL, U-CUP, 1-1/2 x 1/8 x 1-3/4	X	39V52000
27	1	39H51002	O-RING, (-033)	X	39V51002
26	1	91100001	MAGNET, .130 x .312, PS		
25	1	81592132	CAM, SC, LP, 7500/33KN, LH, TC, PR		
24	1	81532115	CAP, END, SC, LP, 33KN/7500, PR		
23	3	81532108	SEAT, BALL, SC, LP, TC		
22	3	81532107	RETAINER, SC, LP, TC		
21	1	81512121	PLUNGER, SC, LP, 7500&33KN, DA, TC, PR		
20	1	81500061	HOUSING, PS, MAG, SC, LP		
19	1	81500060	ADAPTOR, PS, MAG, SC, LP		
18	1	81500051	ROD, ACTUATOR, SC, LP, TF, 7500/33KN		
17	1	81500039	BUSHING, PLUNGER, PR, SC, LP		
16	2	43068006	PLUG, 1/4 BSPP MALE		
15	1	39054017	BU RING, (-033)	X	39054023
14	1	39054016	BU RING, (1.5x.125x.063)	X	X
13	1	39052043	SEAL, LL, (1/4 X 1/8 X 1/8 X 1/2)	X	39V52043
12	1	39052030	SEAL, CROWN, 1-3/4x2-1/8x1/4	X	39V52030
11	2	39050042	O-RING, (-011)	X	39051025
10	3	23650004	BALL, TUNGSTEN-CARBIDE, .250		
9	3	23350066	SPRING, COMPRESSION		
8	10	21500304	SHCS, M6 X 1.0-66 X 20MM		
7	2	21500200	WASHER		
6	1	21500044	SCREW, CAP, BTNH, M3-0.5 X 6, SSSL		
5	3	21500043	SHCS, M3-0.5 X 6, ALY		
4	3	21500031	SHCS, M5 X 0.8 X 14, ALY		
3	2	21500019	SCREW, CAP, BTNH, M3 X 6, ALY		
2	1	21430022	WASHER		
1	1	21410049	SCREW, CAP, SOCH, 8-32 X 3/8, ALY		
No.	QTY	PART No.	DESCRIPTION	Std. Seal Kit	FKM Seal Kit

<h3>PARTS LIST</h3>	<p>VEKTEK, INC. 1334 E. SIXTH AVE. EMPORIA, KS. 66801 U.S.A.</p>
<p>PARTS LIST, ASSY, SC, LP, TC, TF, 33KN, DA, LH, PS</p>	<p>SIZE A</p>
<p>FORM FEG035_PL_ASIZE, REV. B</p>	<p>REV B</p>

B	3886	RELEASE	JDW	07/19/19
REV	IN ACCORDANCE WITH ECN	EFFECTIVE DATE	REVISED BY	DATE
DRW BY:	JDW	DRAWING STATUS: Released		
DATE:	10/16/13	PRODUCTION APPROVED FOR RELEASED STATUS ONLY		

