

APPLY LUBRICANT TO ALL SEALS PRIOR TO INSTALLATION. DO NOT USE SILICONE TYPE LUBRICANTS. FOR PROPER ARM MOUNTING SEE IS1505.

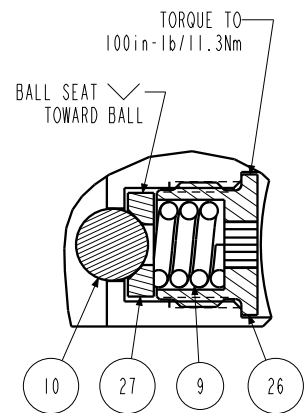

DETAIL A  
SCALE 1.500

N/A	N/A	IS1505	INSTRUCTION SHEET, ARM INSTALLATION		
N/A	N/A	6V711048	SEAL KIT, FKM		
N/A	N/A	60711048	SEAL KIT, STANDARD		
31	1	39V10029	WIPER,PRESS-IN, (1/4)	X	X
30	1	91100001	MAGNET, .130 x .312, PS		
29	1	81591832	CAM,SC,LP,5000/22KN,RH,TC,PR		
28	1	81541817	BASE,SC,BF,LP,22KN,PR		
27	3	81532108	SEAT, BALL, SC, LP, TC		
26	3	81532107	RETAINER, SC, LP, TC		
25	1	81511821	PLUNGER,SC,LP,5000&22KN,DA,TC,PR		
24	1	81500061	HOUSING,PS,MAG,SC,LP		
23	1	81500060	ADAPTOR,PS,MAG,SC,LP		
22	1	81500043	ROD,ACTUATOR,SC,LP,BF,5000/22KN		
21	1	81500039	BUSHING,PLUNGER,PR,SC,LP		
20	2	43068006	PLUG, 1/4 BSSP MALE		
19	1	39054008	BU RING, (-218)	X	X
18	1	39054007	BU RING, (-030)	X	39054021
17	1	39053005	WIPER,SNAP-IN, (1-1/4)	X	X
16	1	39052043	SEAL, LL, (1/4 x 1/8 x 1/8 x 1/2)	X	39V52043
15	1	39051042	O-RING, (-030)	X	39V01021
14	2	39051041	O-RING, (-006)	X	39V51041
13	2	39050042	O-RING, (-011)	X	39051025
12	1	39011060	SEAL,BEVEL W/HEEL INSERT,1-1/4 x1/8 x1-1/2	X	39052015
11	1	39011056	SEAL,CROWN,1-9/16x1-3/4x5/32	X	39V11056
10	3	23650004	BALL,TUNGSTEN-CARBIDE.250		
9	3	23350066	SPRING, COMPRESSION		
8	2	21500200	WASHER		
7	1	21500044	SCREW, CAP, BTNH, M3-0.5 X 6,SSTL		
6	3	21500043	SHCS, M3-0.5 X 6 ALY		
5	3	21500031	SHCS, M5 X 0.8 X 14, ALY		
4	10	21500023	SHCS, M5 X .8-6G X 30MM		
3	2	21500019	SCREW, CAP, BTNH, M3 X 6, ALY		
2	1	21430022	WASHER		
1	1	21410049	SCREW, CAP, SOCH, 8-32 X 3/8, ALY		
No.	QTY	PART No.	DESCRIPTION	Std. Seal Kit	FKM Seal Kit

**PARTS LIST**

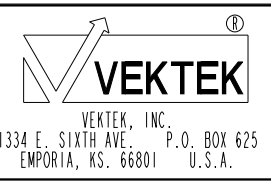

ASSEMBLIES AFFECTED 41422221PS	PARTS LIST, ASSY,SC,LP,TC,BF,22KN,DA,RH,PS
SIZE A	REV B
MPL7227	

B	3677	RELEASE	JDW	03/04/19
REV	IN ACCORDANCE WITH ECN	EFFECTIVE DATE	REVISED BY	DATE
DRW BY:	JDW	<b>DRAWING STATUS: Released</b>		
DATE:	10/16/13	PRODUCTION APPROVED FOR RELEASED STATUS ONLY		

