

SEE ISMV1003 FOR SERVICE INSTRUCTIONS.
LUBRICATE ALL SEALS WITH CLEAN HYDRAULIC OIL PRIOR TO ASSEMBLY.
DO NOT USE SILICONE BASED LUBRICANTS.

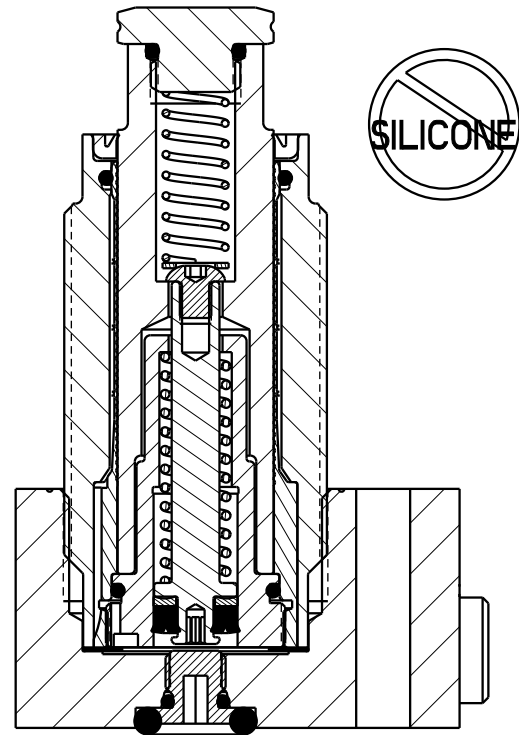

NO	QTY	PART NO	DESCRIPTION	STD SEAL KIT	FKM SEAL KIT	SPRING KIT
1	1	21410075	BHCS, 8-32 x 3/16 SELFLOCK, SST			
2	1	21430001	WASHER			
3	1	23350082	SPRING, COMPRESSION			X
4	1	23350083	SPRING, COMPRESSION			X
5	1	30601123	PLUG, SOCH, SAE 2			
6	1	39000021	O-RING, (-018)	X	39V51020	
7	1	39000050	O-RING, (-204)	X	39051022	
8	1	39002009	O-RING, (-012)	X	X	
9	1	39050028	SEAL, BEVEL, 3/16 X 7/16 X 1/8	X	39V50028	
10	1	39054028	BU RING, (-201)	X	X	
11	1	41040805	BASE, WS, FA, 11&13.4KN			
12	1	43068004	PLUG, SOCH, G1/8			
13	1	47041505	BOLT, CONTACT, WS, FA, 11&13.4&17KN			
14	1	81010815	PISTON, WS, FA, 3000 & 13.4KN, LS			
15	1	81040825	RETAINER, WS, FA, 3000 & 13.4KN, LS			
16	1	39H11062	GASKET, (-213)	X	X	X
17	1	39V50030	WIPER,PRESS-IN, (13/16)			
N/A	N/A	64100119	KIT, SEAL, STANDARD	NOTED	N/A	N/A
N/A	N/A	6V100119	KIT, SEAL, FKM	N/A	NOTED	N/A
N/A	N/A	61100221	KIT, SPRING	N/A	N/A	NOTED
N/A	N/A	ISMV1003	INSTRUCTION SHEET	N/A	N/A	N/A

PARTS LIST

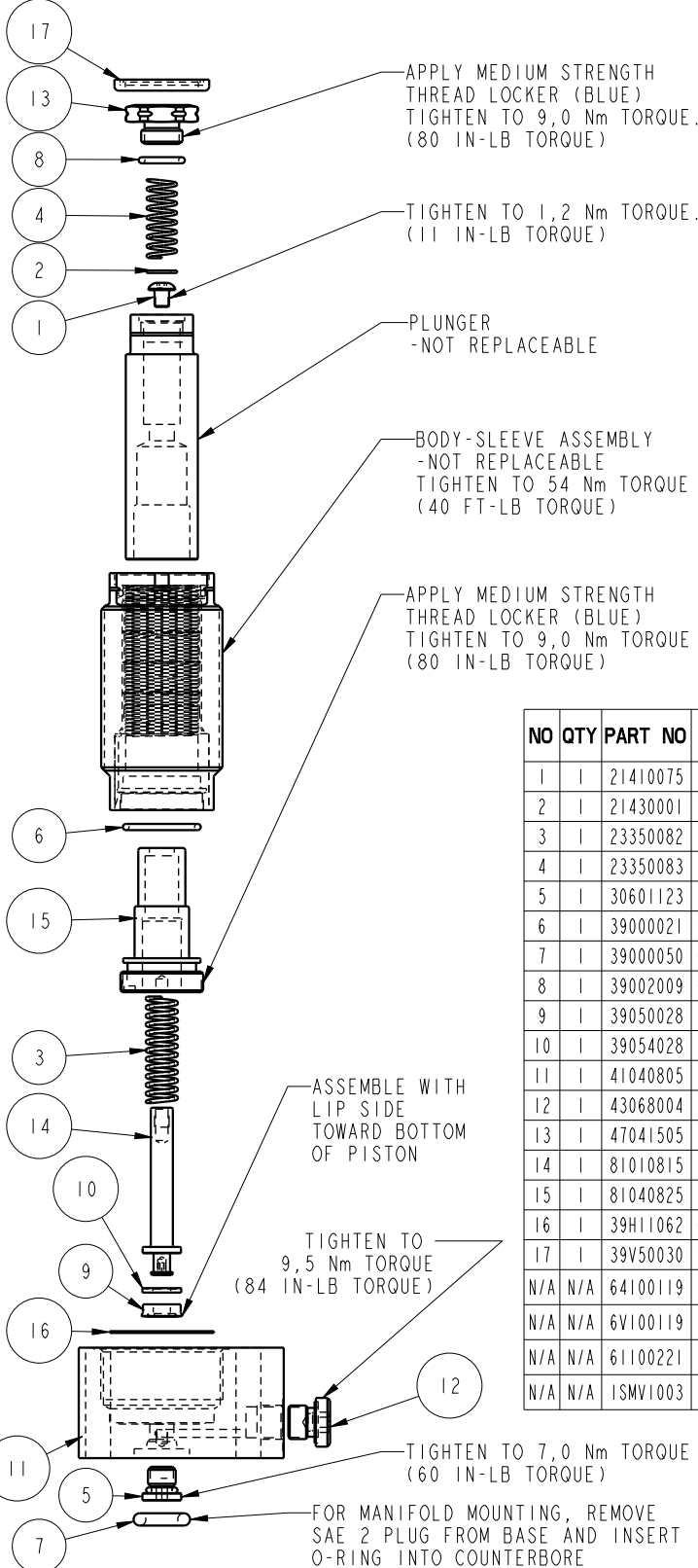

VEKTEK, INC.
1334 E. SIXTH AVE. P.O. BOX 625
EMPORIA, KS. 66801 U.S.A.

ASSEMBLIES AFFECTED
41007013
41007013F

SIZE
A

MPLV1087

REV
B

FORM FEG035_PL_ASIZE, REV. B

B	3130	RELEASE	MAJ	11/3/16
REV	IN ACCORDANCE WITH ECN	EFFECTIVE DATE	REVISED BY	DATE
DRW BY:	JDW	DRAWING STATUS: Released		
DATE:	05/04/12	PRODUCTION APPROVED FOR RELEASED STATUS ONLY		

SHEET 1 OF 1

Vekttek, Inc. 1334 East Sixth Ave. P.O. Box 625 Emporia, Ks. 66801 U.S.A.	Instruction Sheet	ISMV	1003	
		REV:	H, I.A.W. ECN3130	
		REV. BY/DATE:	MAJ	11-3-16
		APPR/DATE:	GY	11-4-16
TITLE: Disassembly/Assembly Instructions: 4.4, 6.2, 11, 13.4 kN Fluid Advance Work Supports				

Read all instructions before disassembly

Refer to the illustration on page three for component part numbers and a tool list.

Disassembly

Notice: When disassembling multiple work supports, the plunger and body/sleeve assembly from each work support should be kept together.

1. Unscrew the body/sleeve assembly (9) from the base (15) or fixture. **Caution- Use a six-point socket only. Other types of wrenches may damage the work support.**
2. Hold the plunger (6) stationary and unscrew the contact bolt (1). Remove o-ring (16) from contact bolt (1).
3. Remove the spring (2) and spacer (10) from inside the plunger (6).
4. Hold the piston (8) stationary and unscrew the cap screw (3).
5. Slide the plunger (6) out of the top of the body/sleeve assembly (9) and then push the piston (8) and spring (13) out of the retainer (14).
6. Remove the wiper (7) from the body/sleeve assembly (9). **Do not scratch the inner sleeve.**
7. Hold the body/sleeve assembly (9) stationary and unscrew the retainer (14) from the body/sleeve assembly (9) using a spanner wrench.
8. Remove the piston seal (11) and piston seal back-up ring (12) from the piston (8), the O-ring (5) from the retainer (14) and the gasket (4) from the base (15) or fixture.
9. Clean all parts thoroughly and set aside to dry.

Vektek, Inc. 1334 East Sixth Ave. P.O. Box 625 Emporia, Ks. 66801 U.S.A.	Instruction Sheet	ISMV	1003	
		REV:	H, I.A.W. ECN3130	
		REV. BY/DATE:	MAJ	11-3-16
		APPR/DATE:	GY	11-4-16
TITLE: Disassembly/Assembly Instructions: 4.4, 6.2, 11, 13.4 kN Fluid Advance Work Supports				

Assembly

1. Lubricate all O-rings, gaskets, back-up rings and seals with clean hydraulic fluid (Vektek 65-0010-01 or equivalent). Apply Loctite primer N® or equivalent to the threads of the contact bolt (1) and the retainer (14) and set aside to dry.
2. Press the wiper (7) into the body/sleeve assembly (9) using only enough force to seat the wiper in the counterbore. **Caution:** Excess force may cause the inner sleeve to collapse.
3. First install the back-up ring (12) then the piston seal (11) onto the piston (8) with the sealing lips of the piston seal (11) toward the piston (8) base.
4. Install the O-ring (5) onto the retainer (14).
5. Apply Loctite 243® or equivalent to the threads of the retainer (14).
6. Hold the body/sleeve assembly (9) stationary and screw the retainer (14) into the body/sleeve assembly (9). Tighten to the torque specification on the parts list.
7. Slide the spring (13) onto the piston (8) and insert both parts into the retainer (14)
8. Insert the plunger (6) into the top of the body/sleeve assembly (9).
9. While holding the piston (8) stationary insert the cap screw (3) into the top of the plunger (6) and thread the cap screw (3) into the piston (8). Tighten to the specification on the parts list.
10. Insert the flat washer (10) and the spring (2) into the top of the plunger (6).
11. Install o-ring (16) onto contact bolt (1). Apply one drop of Loctite 243® or equivalent to the threads of the contact bolt (1). While holding the plunger (6) stationary tighten the contact bolt (1) to the plunger (6). Tighten to the torque specification on the parts list.
12. Place the gasket (4) flat in the bottom of the base (15) or mounting cavity. Insert the work support assembly into the base (15) or mounting cavity and tighten it to the torque specification on the parts list.
Caution- Use a six-point socket only. Other types of wrenches may damage the work support.

Vekttek, Inc. 1334 East Sixth Ave. P.O. Box 625 Emporia, Ks. 66801 U.S.A.	Instruction Sheet	ISMV 1003
		REV: H, I.A.W. ECN3130
		REV. BY/DATE: MAJ 11-3-16
		APPR/DATE: GY 11-4-16
TITLE: Disassembly/Assembly Instructions: 4.4, 6.2, 11, 13.4 kN Fluid Advance Work Supports		

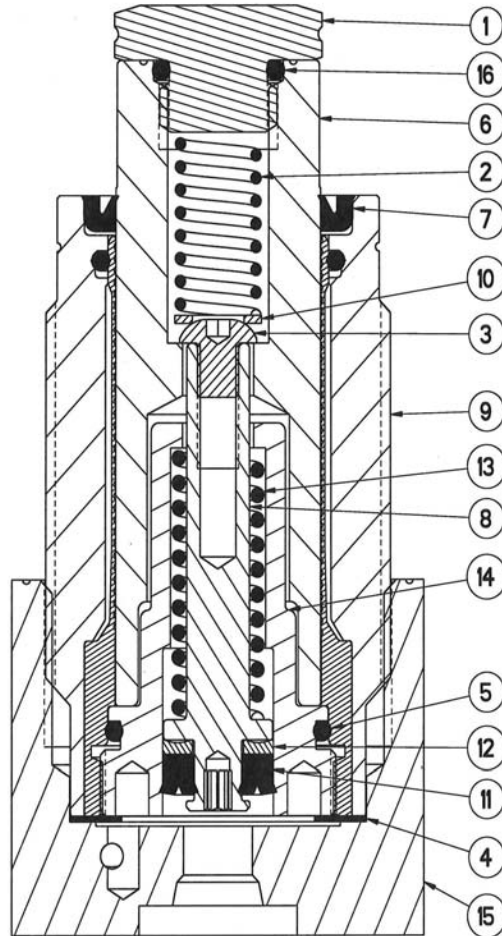

16	O-RING
15	BASE
14	RETAINER
13	SPRING
12	BACK-UP RING
11	SEAL
10	SPACER
9	BODY/SLEEVE ASSY
8	PISTON
7	WIPER
6	PLUNGER
5	O-RING
4	GASKET
3	CAP SCREW
2	SPRING
1	CONTACT BOLT
Item	Description

Model Number	Tool List
41-0070-00 41-0070-04 41-0070-14 41-0071-00 41-0071-04 41-0071-14 6964H-04-1 6964H-04-2	14 mm open end, 13 & 23 mm socket (six point) 1/16 & 5/64 hex keys, spanner wrench
41-0070-01 41-0070-03 41-0070-13 41-0071-01 41-0071-03 41-0071-13 6964H-11-1 6964H-11-2	18 mm open end, 19 & 30 mm socket (six point) 1/8 & 3/32 (2) hex keys, spanner wrench