

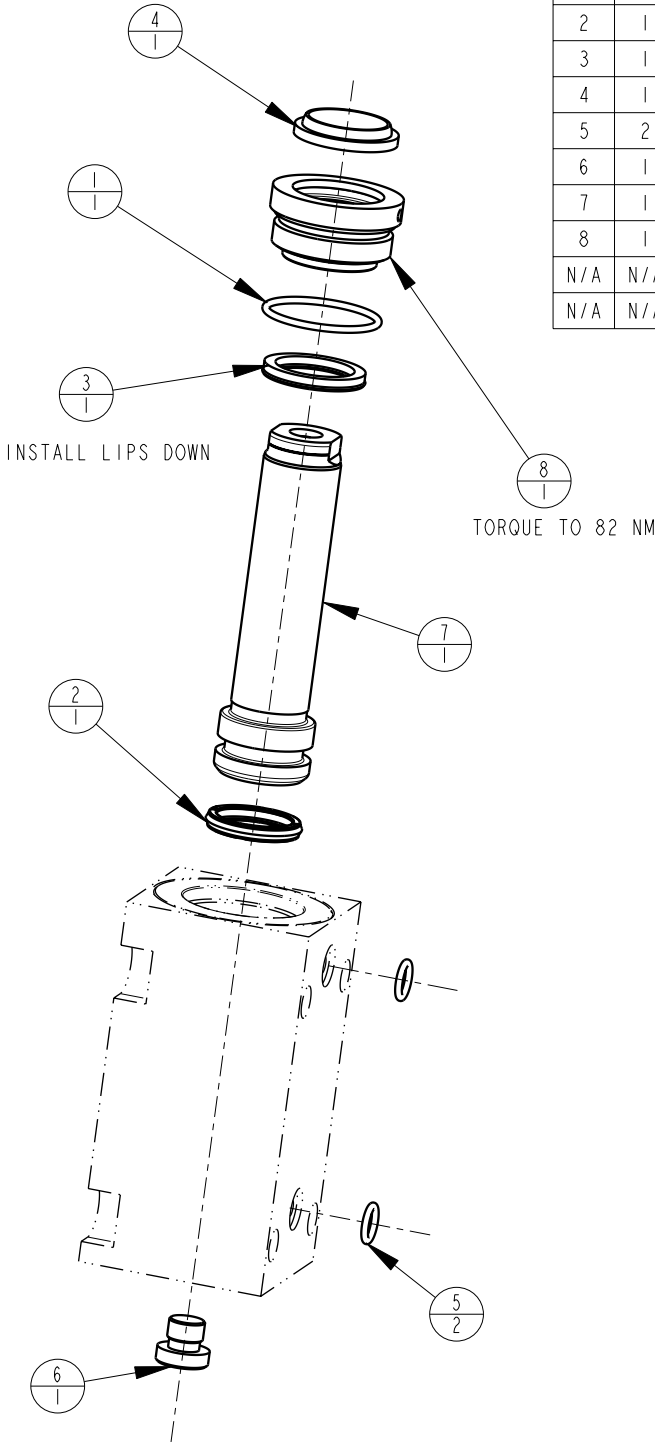

MODEL NO.			MODEL NAME
42112004			ASSY,CYL, BB, MM, 17,8KN, 51 STRK,DA
NO.	QTY	PART NO.	DESCRIPTION
1	1	39001011	O-RING, (-024)
2	1	39010017	SEAL,CROWN,13/16x1x5/32
3	1	39011045	SEAL, LL, (13/16 X 1/8 X 1/8 X 1-1/16)
4	1	39012008	WIPER,SNAP-IN, (13/16)
5	2	39050042	O-RING, (-011)
6	1	43068004	PLUG, 1/8 BSPP
7	1	48011002	METRIC PISTON, CYL., 51,0 STRK., 17,8 kN
8	1	82031002	GLAND,CYL, 3900 & 17.8 KN
N/A	N/A	60210401	KIT, SEAL, BB, 17,8 KN, DA
N/A	N/A	6V210210	KIT, SEAL, BB, 3900/17,8 KN, DA, FKM



2. ALL SEALS, O-RINGS, AND WIPERS ARE INCLUDED IN THE STANDARD OR FKM SEAL KIT.
1. APPLY LUBRICANT TO ALL SEALS PRIOR TO ASSEMBLY (DO NOT USE SILICONE TYPE LUBRICANTS).

NOTE:

PARTS LIST	 VEKTEK, INC. 1334 E. SIXTH AVE. P.O. BOX 625 EMPORIA, KS. 66801 U.S.A.
	PARTS LIST, BB, MM, 17,8 KN, DA
ASSEMBLIES AFFECTED 42-1120-04	SIZE A MPLV2161
FORM FEG035_PL_ASIZE, REV. B	

B	2625	RELEASE	GAR	2/28/14
REV	IN ACCORDANCE WITH ECN	EFFECTIVE DATE	REVISED BY	DATE
DRW BY:	G. ROMINE	DRAWING STATUS: Released		
DATE:	11/19/07	PRODUCTION APPROVED FOR RELEASED STATUS ONLY		

SHEET 1 OF 1