

NO	QTY	PART NO	DESCRIPTION	42-1140-00	42-1140-01	STD SEAL KIT
1	1	2335012	SPRING, COMPRESSION	X	X	
2	2	23520004	PIN, SPRING, SLOTTED, 1/8 X 5/8, SST	X	X	
3	1	39010019	SEAL, LL, (1/2 X 1/8 X 1/8 X 3/4)	X	X	X
4	1	39012009	WIPER, PRESS-IN, (1/2)	X	X	X
5	2	39051125	O-RING, (-025)	X	X	X
6	1	39052044	SEAL, U-CUP, 3/4 X 1/8 X 1	X	X	X
-	1	67010153	TAG, INSTALL, CYL, CM, SLIP-IN	X	X	X
7	1	82140021	PLUNGER, CYL, CM, PULL, 13.1kN	X		
-	1	82140022	PLUNGER, CYL, CM, PULL, 13.1kN		X	
8	2	39F54003	BU RING, (-025)	X	X	X
N/A	N/A	64014130	RETAINER, MNTG, CYL, CM, 2950LB	N/A	N/A	N/A
N/A	N/A	60210116	KIT, SEAL, CYL, CM, PULL, 2950LB	N/A	N/A	NOTED
N/A	N/A	IS2102	INSTRUCTIONS, INSTALL, CYL, CM, SLIP-IN	N/A	N/A	N/A

WHEN USED WITH OPTIONAL RETAINING RING P/N 64-0141-10
TORQUE M6 X 1.0 BOLTS TO 7.0 N-m (62 IN-LBS)

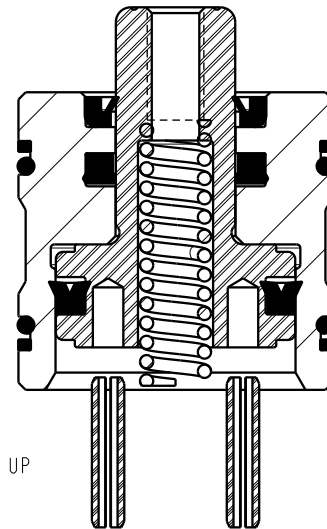
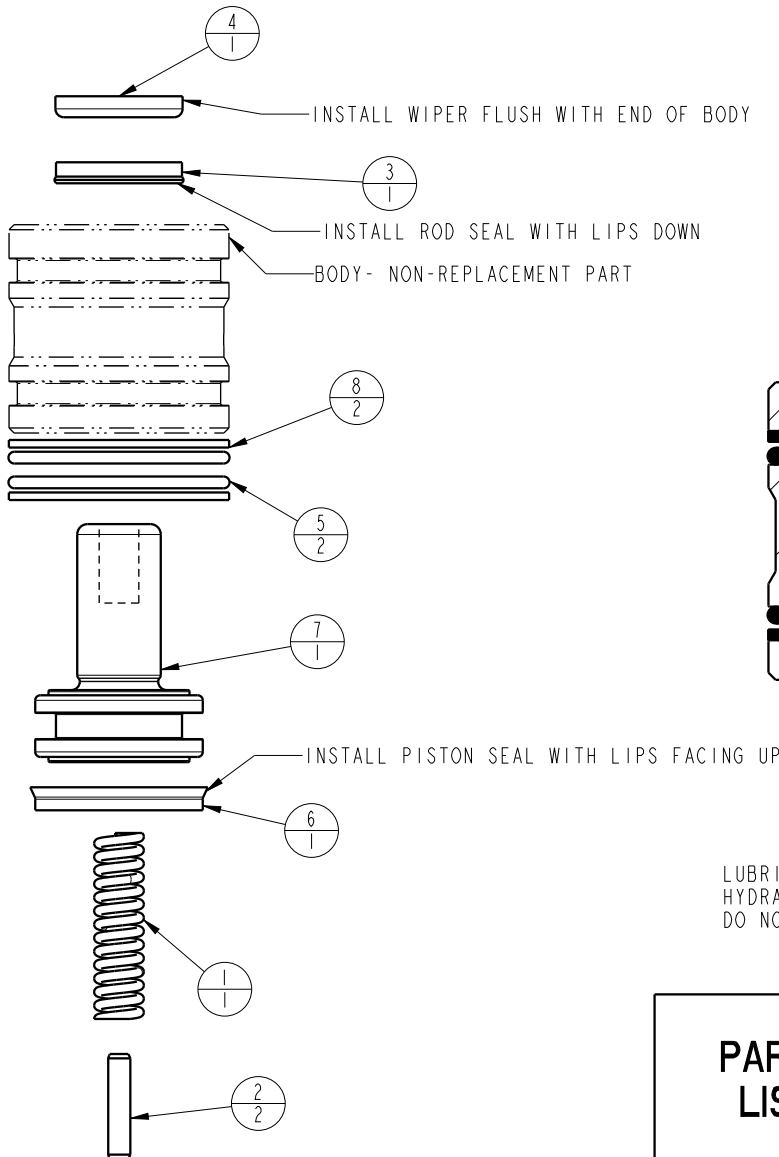

LUBRICATE ALL SEALS WITH CLEAN HYDRAULIC OIL PRIOR TO ASSEMBLY
DO NOT USE SILICONE BASED LUBRICANTS

PARTS LIST



VEKTEK, INC.
1334 E. SIXTH AVE. P.O. BOX 625
EMPORIA, KS. 66801 U.S.A.

ASSEMBLIES AFFECTED
42114000, 42114001

PARTS LIST, CYL, CM, PULL, 13.1kN
SLIP-IN CARTIDGE MOUNT

SIZE
A MPLV2181

REV
A

A	3136	RELEASE	DKC	11/8/16
REV	IN ACCORDANCE WITH ECN	EFFECTIVE DATE	REVISED BY	DATE
DRW BY:	DKC	DRAWING STATUS: Released		
DATE:	11/3/16	PRODUCTION APPROVED FOR RELEASED STATUS ONLY		

SHEET 1 OF 1

CAVITY AND INSTALLATION INSTRUCTIONS

PLEASE READ PRIOR TO OPERATION

Cavity Forming

-It is recommended that all cavities be prepared using a ball hone such as a *Flex-Hone™. This will deburr and round sharp edges to prevent seal damage. The honing prepares cavity for cylinder installation.

-Intersecting feed holes should be adequately deburred and chamfered to prevent seal damage.

*Flex-hone™ is a registered trademark of:
 Brush Research Manufacturing Co. Inc.
 Los Angeles, CA, 323-261-2193
 Please Contact Brush Research for additional information.

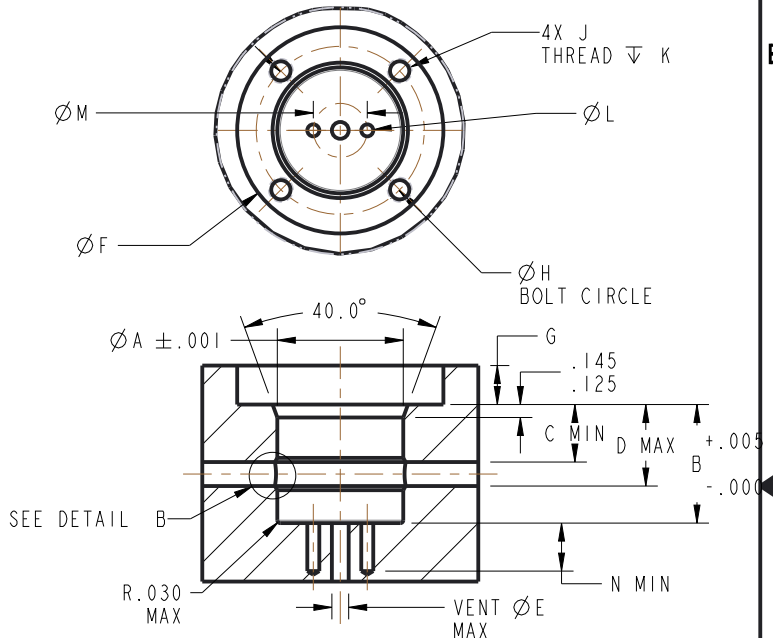
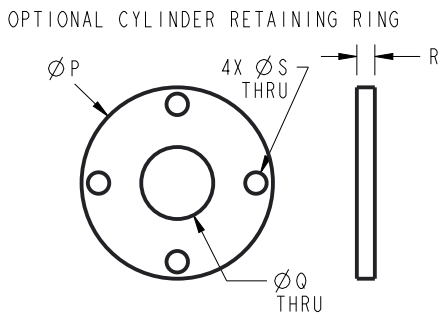
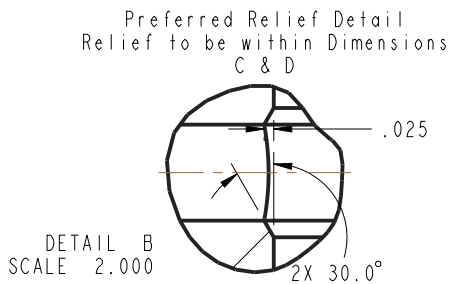

MODEL NO.	CAPACITY	A	B	C	D	E	F	G	H	J	K	L*	M*	N*	P	Q	R	S
21-4106-XX	980	.813	1.120	.44	.72	.16	1.40	.31	1.13	8-32 UNC	.33	.13	.44	.31	1.330	.50	.125	.173
21-4109-00	2000	1.188	1.120	.44	.72	.18	1.86	.31	1.56	8-32 UNC	.33	.13	.53	.40	1.832	.75	.125	.173
21-4109-01	2000	1.188	1.245	.44	.84	.18	1.86	.31	1.56	8-32 UNC	.33	.13	.53	.40	1.832	.75	.125	.173
21-4111-XX	2950	1.313	1.245	.44	.84	.18	2.15	.41	1.75	1/4-20 UNC	.38	.13	.56	.40	2.125	.75	.125	.257
21-4113-XX	5200	1.751	1.370	.44	.97	.33	2.83	.53	2.31	5/16-18 UNC	.47	.16	.88	.40	2.782	1.00	.187	.328
21-4116-XX	9000	2.126	1.495	.44	1.09	.35	3.40	.67	2.81	3/8-16 UNC	.50	.28	1.00	.60	3.375	1.12	.250	.391
21-4121-00	17100	2.876	1.620	.44	1.22	.40	4.59	.90	3.81	1/2-13 UNC	.63	.28	1.57	.60	4.563	1.25	.375	.515

NOTE: CAVITY UTILIZES OPTIONAL RETAINING RING AVAILABLE FROM VEKTEK, INC.
 ADDITIONAL RETAINING RING INFORMATION IS CONTAINED IN SHEET 3.

*THESE FEATURES ARE ONLY NEEDED IF ANTI-ROTATION PINS ARE USED.

**ANTI-ROTATE PINS AND RETURN SPRINGS INCLUDED WITH CYLINDERS.

INSTALLATION INSTRUCTIONS



VEKTEK, INC.
 1334 E. SIXTH AVE. P.O. BOX 625
 EMPORIA, KS. 66801 U.S.A.

A	2753	RELEASE	DKC	10/1/14
REV	IN ACCORDANCE WITH ECN	EFFECTIVE DATE	REVISED BY	DATE
DRW BY:	DKC	DRAWING STATUS: Released		
DATE:	9/23/14	PRODUCTION APPROVED FOR RELEASED STATUS ONLY		

ASSEMBLIES AFFECTED
 21-4106-XX 21-4109-XX
 21-4111-XX 21-4113-XX
 21-4116-XX 21-4121-00

INSTRUCTIONS, INSTALL, CTL, CH, SLIP-IN	
SLIP IN	REV A
SIZE A	IS2102

FORM FEG041-1S.AS1Z, REV. B

SHEET 1 OF 3

1 ↓ 2

INSTALLATION INSTRUCTIONS CONTINUED

Anti-Rotation Pins

- Anti-Rotation Pins are only to resist normal rotational force from cylinder actuation. The pins are not intended to resist torque from other applications.
- The use of anti-rotation pins are not required, but may be used to prevent plunger rotation.
- Anti-Rotation Pins (included with each device) are sized to have sufficient length to fully engage in plunger as well as have engagement in the fixture greater than the total plunger stroke.
- Replacement anti-rotation pin part numbers are below for each size of cylinder.

MODEL NO.	PIN NO.
21-4106-XX	90-1999-70
21-4109-XX	23-5200-03
21-4111-XX	23-5200-04
21-4113-XX	23-5200-04
21-4116-XX	23-5200-05
21-4121-00	23-5200-05

Installation of Anti-Rotation Pins

- Press rod end of plunger flush with the end of the cylinder body. See view below. Care must be taken not to push the rod out of the rod seal. Piston seal may be exposed in certain cylinder models.

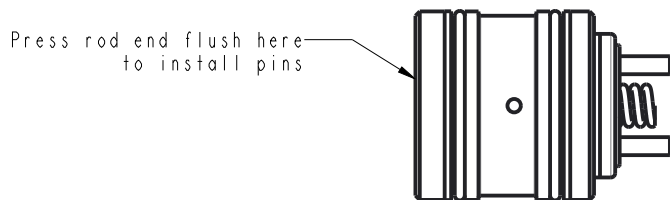

- Press in the pins provided. Ensure pins start straight and are fully seated in the plunger. (An increase in resistance will be felt when pin is fully seated.)

NOTE: If piston seal was exposed during anti-rotation pin installation, Lubricate seal with non-silicone grease or clean hydraulic oil prior to reinstallation.

- With both pins installed, carefully press piston end of the plunger even with end of body. See view below.

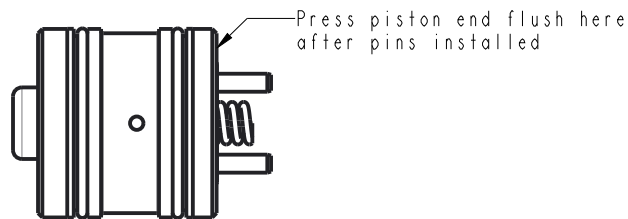

- Cylinder is ready for installation into fixture.

INSTALLATION INSTRUCTIONS	 <small>VEKTEK, INC. 1334 E. SIXTH AVE. P.O. BOX 625 EMPORIA, KS. 66801 U.S.A.</small>
ASSEMBLIES AFFECTED	INSTRUCTIONS, INSTALL, CTL, CN, SLIP-IN
21-4106-XX 21-4109-XX	SLIP IN
21-4111-XX 21-4113-XX	SIZE IS2102 REV A
21-4116-XX 21-4121-00	FORM FEG041-IS.AS1ZE, REV. B

A	2753	RELEASE	DKC	10/1/14
REV	IN ACCORDANCE WITH ECN	EFFECTIVE DATE	REVISED BY	DATE
DRW BY: DKC	DRAWING STATUS: Released			
DATE: 9/23/14	PRODUCTION APPROVED FOR RELEASED STATUS ONLY			

SHEET 2 OF 3

1

2

INSTALLATION INSTRUCTIONS CONTINUED

Installation Notes

- It is recommended that all cavities be prepared using a ball hone such as a *Flex-Hone™. This will deburr and round sharp edges to prevent seal damage and prepare cavity for cylinder installation.
- All seals should be lubricated with a non-silicone grease (recommended) or clean hydraulic oil prior to installation.

Installation

1. Lubricate all seals with non-silicone grease (recommended) or clean hydraulic oil.
2. Install return spring in plunger cavity with a small amount of grease to hold it in place during installation. See view below. A table of return spring part numbers is included below.

Cylinder P/N	Return Spring P/N
21-4106-XX	23-3550-11
21-4109-XX	23-3550-12
21-4111-XX	23-3550-12
21-4113-XX	23-3550-14
21-4116-XX	23-3550-15
21-4121-00	23-3550-16

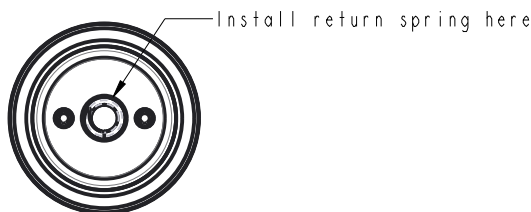

3. If using anti-rotate pins install a bolt and jam nut in plunger to help align pins. Press the piston end of the plunger even with end of body. See view below.

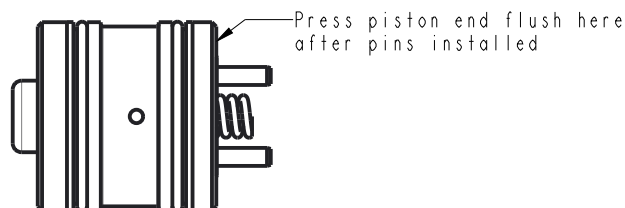

- a. Press cylinder into cavity until plunger begins to extend ensuring cylinder goes in evenly to prevent cavity or seal damage.
 - b. Using the bolt gently turn the plunger while applying slight downward force until plunger begins to retract. This ensures alignment of the anti-rotation pins.
 - c. Remove bolt and jam nut. Visually inspect spring through threaded hole in plunger to verify return spring is properly positioned.
4. Press cylinder body until flush with the start of the cavity. Stop if an increase in resistance is felt.
 - a. If using the optional retention ring, see chart below for proper torque.

MODEL NO.	RETAINER NO.	BOLT SIZE	TORQUE
21-4106-XX	64-0140-80	8-32 UNC	29 IN-LBS
21-4109-XX	64-0141-10	8-32 UNC	29 IN-LBS
21-4111-XX	64-0141-30	1/4-20 UNC	63 IN-LBS
21-4113-XX	64-0141-70	5/16-18 UNC	20 FT-LBS
21-4116-XX	64-0142-10	3/8-16 UNC	24 FT-LBS
21-4121-00	64-0142-80	1/2-13 UNC	62 FT-LBS

INSTALLATION INSTRUCTIONS



VEKTEK, INC.
1334 E. SIXTH AVE. P.O. BOX 625
EMPORIA, KS. 66801 U.S.A.

A	2753	RELEASE	DKC	10/1/14
REV	IN ACCORDANCE WITH ECN	EFFECTIVE DATE	REVISED BY	DATE
DRW BY: DKC	DRAWING STATUS: Released			
DATE: 9/23/14	PRODUCTION APPROVED FOR RELEASED STATUS ONLY			

ASSEMBLIES AFFECTED

21-4106-XX 21-4109-XX
21-4111-XX 21-4113-XX
21-4116-XX 21-4121-00

INSTRUCTIONS, INSTALL, CTL, CN, SLIP-IN

SLIP IN

SIZE
A

IS2102

REV
A

1

2

FORM FEG041-1S.AS1ZE, REV. B

SHEET 3 OF 3