

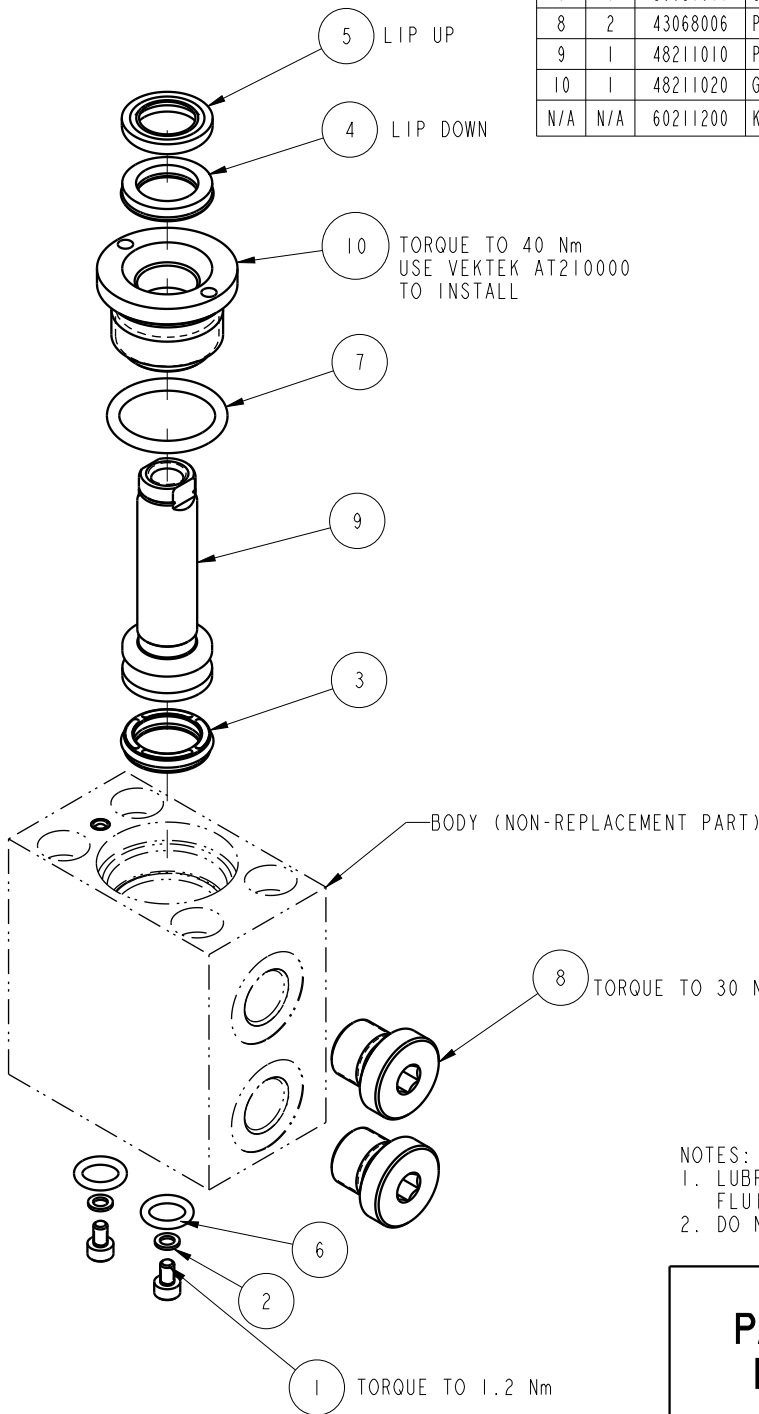

NO	QTY	PART NO	DESCRIPTION	STD SEAL KIT
1	2	21500018	SCREW, CAP, SOCH, M3 X 5, ALY	
2	2	21500200	WASHER	
3	1	39010016	SEAL, CROWN, 9/16x3/4x5/32	X
4	1	39010019	SEAL, LL, (1/2 X 1/8 X 1/8 X 3/4)	X
5	1	39012009	WIPER, PRESS-IN, (1/2)	X
6	2	39050042	O-RING, (-011)	X
7	1	39051071	O-RING, (-117)	X
8	2	43068006	PLUG, PORT, HOLLOW HEX, G1/4	
9	1	48211010	PISTON, CYL, BB, COMBO, 10 KN, 16	
10	1	48211020	GLAND, CYL, BB, COMBO, 10 KN	
N/A	N/A	60211200	KIT, SEAL, CYL, BB, COMBO, DA, 10 KN	NOTED



- NOTES:
- LUBRICATE ALL SEALS WITH CLEAN HYDRAULIC FLUID PRIOR TO INSTALLATION.
  - DO NOT USE SILICONE TYPE LUBRICANTS.

<b>PARTS LIST</b>	 VEKTEK, INC. 1334 E. SIXTH AVE. P.O. BOX 625 EMPORIA, KS. 66801 U.S.A.	
	ASSEMBLIES AFFECTED	PARTS LIST, CYL, BB, COMBO, DA, 10 KN, 16
REV	DATE	REV
D 4246	8/4/20	D
IN ACCORDANCE WITH ECN	EFFECTIVE DATE	DATE
REV	REVISED BY	DATE
DRW BY: K. ROEMER	<b>DRAWING STATUS: Released</b>	
DATE: 11/09/11	PRODUCTION APPROVED FOR RELEASED STATUS ONLY	
SIZE A	MPLV4200	REV D

FORM FEG035\_PL\_ASIZE, REV. B