

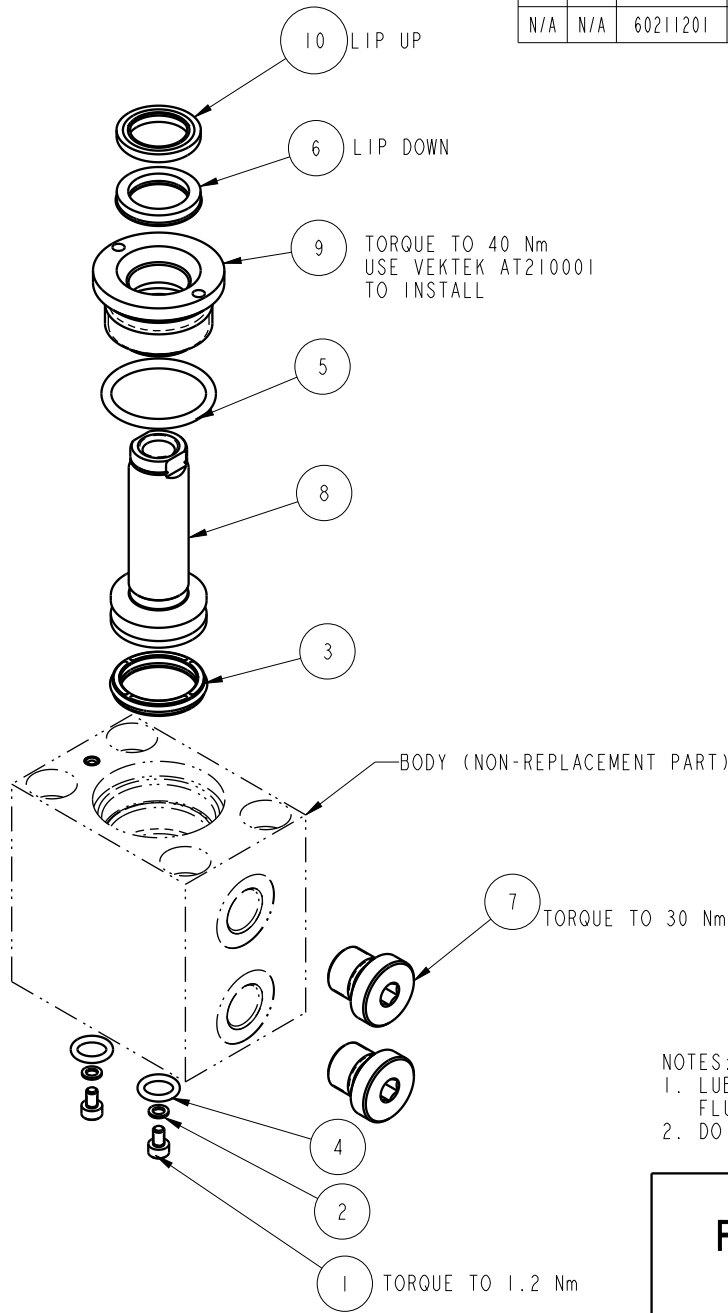

| NO | QTY | PART NO | DESCRIPTION | STD SEAL KIT |
|-----|-----|----------|--|--------------|
| 1 | 2 | 21500018 | SCREW, CAP, SOCH, M3 X 5, ALY | |
| 2 | 2 | 21500200 | WASHER | |
| 3 | 1 | 39010017 | SEAL,CROWN,13/16x1x5/32 | X |
| 4 | 2 | 39050042 | O-RING, (-011) | X |
| 5 | 1 | 39051072 | O-RING, (-120) | X |
| 6 | 1 | 39052036 | SEAL, LL, (5/8 X 1/8 X 1/8 X 7/8) | X |
| 7 | 2 | 43068006 | PLUG, PORT, HOLLOW HEX, G1/4 | |
| 8 | 1 | 48211012 | PISTON, CYL, BB, COMBO, 17,7 KN, 20 | |
| 9 | 1 | 48211021 | GLAND, CYL, BB, COMBO, 17,7 KN | |
| 10 | 1 | 39V11020 | WIPER,PRESS-IN, (5/8) | X |
| N/A | N/A | 60211201 | KIT, SEAL, CYL, BB, COMBO, DA, 17.7 KN | NOTED |



- NOTES:
- LUBRICATE ALL SEALS WITH CLEAN HYDRAULIC FLUID PRIOR TO INSTALLATION.
 - DO NOT USE SILICONE TYPE LUBRICANTS.

| | | |
|---------------------|---|----------|
| PARTS LIST |  | |
| | VEKTEK, INC. 1334 E. SIXTH AVE. P.O. BOX 625 EMPORIA, KS. 66801 U.S.A. | |
| ASSEMBLIES AFFECTED | PARTS LIST,CYL,BB,COMBO,DA,17.7 KN,20 | |
| 42112102 | | |
| L2112102 | SIZE A | MPLV4202 |
| | | REV D |

| | | | | |
|-------------------|--|----------------|------------|--------|
| D | 4246 | RELEASE | MJUST | 8/4/20 |
| REV | IN ACCORDANCE WITH ECN | EFFECTIVE DATE | REVISED BY | DATE |
| DRW BY: K. ROEMER | DRAWING STATUS: Released | | | |
| DATE: 11/09/11 | PRODUCTION APPROVED FOR RELEASED STATUS ONLY | | | |