

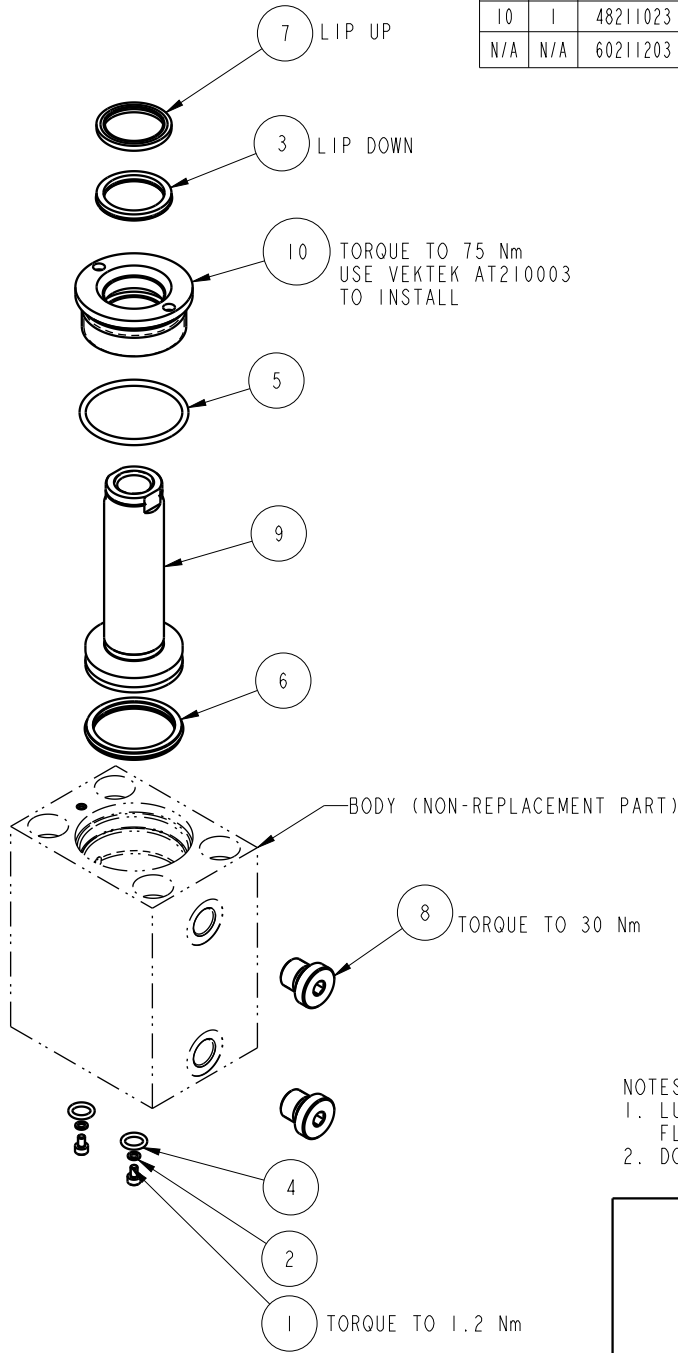

NO	QTY	PART NO	DESCRIPTION	STD SEAL KIT
1	2	21500018	SCREW, CAP, SOCH, M3 X 5, ALY	
2	2	21500200	WASHER	
3	1	39011047	SEAL, LL, (1 X 1/8 X 1/8 X 1-1/4)	X
4	2	39050042	O-RING, (-011)	X
5	1	39051074	O-RING, (-130)	X
6	1	39052035	SEAL, CROWN, 1-3/8x1-5/8x5/32	X
7	1	39053003	WIPER, PRESS-IN, (1)	X
8	2	43068006	PLUG, PORT, HOLLOW HEX, G1/4	
9	1	48211017	PISTON, CYL, BB, COMBO, 46,8 KN, 50	
10	1	48211023	GLAND, CYL, BB, COMBO, 46,8 KN	
N/A	N/A	60211203	KIT, SEAL, CYL, BB, COMBO, DA, 46.8 KN	NOTED



- NOTES:
- LUBRICATE ALL SEALS WITH CLEAN HYDRAULIC FLUID PRIOR TO INSTALLATION.
 - DO NOT USE SILICONE TYPE LUBRICANTS.

PARTS LIST	 VEKTEK VEKTEK, INC. 1334 E. SIXTH AVE. P.O. BOX 625 EMPORIA, KS. 66801 U.S.A.
	ASSEMBLIES AFFECTED 42112107 L2112107
PARTS LIST, CYL, BB, COMBO, DA, 46.8 KN, 50	SIZE A MPLV4207

D	4246	RELEASE	MJUST	8/4/20
REV	IN ACCORDANCE WITH ECN	EFFECTIVE DATE	REVISED BY	DATE
DRW BY:	K. ROEMER	DRAWING STATUS: Released		
DATE:	11/09/11	PRODUCTION APPROVED FOR RELEASED STATUS ONLY		

SHEET 1 OF 1