

APPLY LUBRICANT TO ALL SEALS PRIOR TO INSTALLATION. DO NOT USE SILICONE TYPE LUBRICANTS. FOR PROPER ARM MOUNTING SEE IS1505.

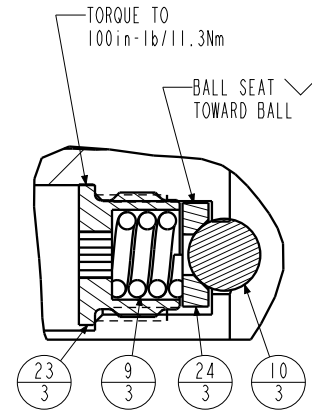

DETAIL A
SCALE 1.500

N/A	N/A	IS1505	INSTRUCTION SHEET, ARM INSTALLATION		
N/A	N/A	N/A	SPRING KIT		
N/A	N/A	6V711050	SEAL KIT, FKM		
N/A	N/A	60711050	SEAL KIT, STANDARD		
31	1	39V11051	WIPER, PRESS-IN, (1-1/2)	X	X
30	1	39V10029	WIPER, PRESS-IN, (1/4)	X	X
29	1	39H52000	SEAL, U-CUP, 1-1/2 x 1/8 x 1-3/4	X	39V52000
28	1	39H51002	O-RING, (-033)	X	39V51002
27	1	91100001	MAGNET, .130 x .312, PS		
26	1	81592137	CAM, SC, LP, 7500/33KN, LH, LS, TC, PR		
25	1	81542112	BASE, SC, BF, LP, 33KN, PR		
24	3	81532108	SEAT, BALL, SC, LP, TC		
23	3	81532107	RETAINER, SC, LP, TC		
22	1	81512122	PLUNGER, SC, LP, 7500/33KN, DA, LS, TC, PR		
21	1	81500062	HOUSING, PS, MAG, SC, LP, LS		
20	1	81500060	ADAPTOR, PS, MAG, SC, LP		
19	1	81500054	ROD, ACTUATOR, SC, LP, BF, 7500/33KN, LS		
18	1	81500039	BUSHING, PLUNGER, PR, SC, LP		
17	2	43068006	PLUG, 1/4 BSPP MALE		
16	1	39054017	BU RING, (-033)	X	39054023
15	1	39054016	BU RING, (1.5x.125x.063)	X	X
14	1	39052043	SEAL, LL, (1/4 x 1/8 x 1/8 x 1/2)	X	39V52043
13	1	39052030	SEAL, CROWN, 1-3/4x2-1/8x1/4	X	39V52030
12	2	39051041	O-RING, (-006)	X	39V51041
11	2	39050042	O-RING, (-011)	X	39051025
10	3	23650004	BALL, TUNGSTEN-CARBIDE. 250		
9	3	23350066	SPRING, COMPRESSION		
8	10	21500305	SHCS, M8 X 1.25-66 X 30MM		
7	2	21500200	WASHER		
6	1	21500044	SCREW, CAP, BTNH, M3-0.5 X 6, SSSL		
5	3	21500043	SHCS, M3-0.5 X 6, ALY		
4	3	21500031	SHCS, M5 X 0.8 X 14, ALY		
3	2	21500019	SCREW, CAP, BTNH, M3 X 6, ALY		
2	1	21430022	WASHER		
1	1	21410049	SCREW, CAP, SOCH, 8-32 X 3/8, ALY		
No.	QTY	PART No.	DESCRIPTION	Std. Seal Kit	FKM Seal Kit

PARTS LIST



VEKTEK, INC.
1334 E. SIXTH AVE. P.O. BOX 625
EMPORIA, KS. 66801 U.S.A.

ASSEMBLIES AFFECTED

41423327PS

41423327PSF

PARTS LIST, ASSY, SC, LP, TC, BF, 33KN, DA, LH, LS, PS

SIZE
A

MPLV7261

REV
A

SHEET 1 OF 1

A	3677	RELEASE	JDW	03/04/19
REV	IN ACCORDANCE WITH ECN	EFFECTIVE DATE	REVISED BY	DATE
DRW BY:	JDW	DRAWING STATUS: Released		
DATE:	03/04/19	PRODUCTION APPROVED FOR RELEASED STATUS ONLY		

