

APPLY LUBRICANT TO ALL SEALS PRIOR TO INSTALLATION. DO NOT USE SILICONE TYPE LUBRICANTS. FOR PROPER ARM MOUNTING SEE ISI505.

TORQUE TO 100 in-lb/11.3 Nm
BALL SEAT TOWARD BALL

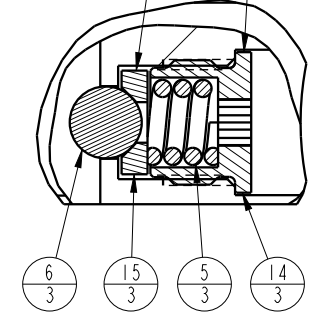

DETAIL A
SCALE 1.500

No.	QTY	PART No.	DESCRIPTION	Std. Seal Kit	FKM Seal Kit
N/A	N/A	ISI505	INSTRUCTION SHEET, ARM INSTALLATION		
N/A	N/A	6V711044	SEAL KIT, FKM		
N/A	N/A	60711044	SEAL KIT, STANDARD		
20	1	39V11051	WIPER, PRESS-IN, (1-1/2)	X	X
19	1	39H52000	SEAL, U-CUP, 1-1/2 x 1/8 x 1-3/4	X	39V52000
18	1	39H51002	O-RING, (-033)	X	39V51002
17	1	81592128	CAM, SC, LP, 7500, STR, LS, TC		
16	1	81542102	BASE, SC, BF, LP, 33KN		
15	3	81532108	SEAT, BALL, SC, LP, TC		
14	3	81532107	RETAINER, SC, LP, TC		
13	1	81512112	PLUNGER, SC, LP, 7500/33KN, DA, LS, TC		
12	2	43068006	PLUG, 1/4 BSPP MALE		
11	1	39054017	BU RING, (-033)	X	39054023
10	1	39054016	BU RING, (1.5x.125x.063)	X	X
9	1	39052030	SEAL, CROWN, 1-3/4x2-1/8x1/4	X	39V52030
8	2	39051041	O-RING, (-006)	X	39V51041
7	2	39050042	O-RING, (-011)	X	39051025
6	3	23650004	BALL, TUNGSTEN-CARBIDE. 250		
5	3	23350066	SPRING, COMPRESSION		
4	10	21500305	SHCS, M8 X 1.25-6G X 30MM		
3	2	21500200	WASHER		
2	3	21500031	SHCS, M5 X 0.8 X 14, ALY		
1	2	21500019	SCREW, CAP, BTNH, M3 X 6, ALY		

PARTS LIST



VEKTEK, INC.
1334 E. SIXTH AVE. P.O. BOX 625
EMPORIA, KS. 66801 U.S.A.

ASSEMBLIES AFFECTED
41423328
41423328F

SIZE A
MPLV7262

REV A

SHEET 1 OF 1

A	3677	RELEASE	JDW	03/04/19
REV	IN ACCORDANCE WITH ECN	EFFECTIVE DATE	REVISED BY	DATE
DRW BY:	JDW	DRAWING STATUS: Released		
DATE:	03/04/19	PRODUCTION APPROVED FOR RELEASED STATUS ONLY		

1 ↓ **2**

READ ALL INSTRUCTIONS BEFORE INSTALLING ARMS FAILURE TO FOLLOW INSTALLATION INSTRUCTIONS WILL VOID PRODUCT WARRANTY !

-Installing or Positioning of Low Profile Swing Clamp Arms-

**NOTE: If the arm is already installed on the plunger,
loosen the cap screw.**

**CAUTION: Never attempt to rotate the arm before loosening
the cap screw. This can damage the plunger rotating mechanism.**

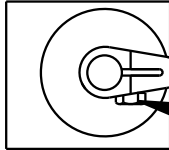

- 1. Rotate the arm to the desired radial position.**
- 2. Tighten to the torque specification listed below.**

MODEL	TORQUE ft-lb	TORQUE N-m
5000lb & 22Kn	115 ft-lb	156 N-m
7500lb & 33Kn	225 ft-lb	305 N-m

**IT IS RECOMMEND THE CROSS BOLT
BE REPLACED IF THE ARM NEEDS
REMOVED AFTER IT HAS BEEN IN SERVICE.**

CROSS BOLT	CROSS BOLT	CROSS BOLT	CROSS BOLT
5000 & 22KN	5000 & 22KN	7500 & 33KN	7500 & 33KN
SHORT LONG DOUBLE	UPREACH	SHORT LONG DOUBLE	UPREACH
21-5000-24	21-5000-25	21-5000-28	21-5000-25

**Instruction
Sheet**



VEKTEK, INC.
1334 E. SIXTH AVE. P.O. BOX 625
EMPORIA, KS. 66801 U.S.A.

Arm Installation Instruction Sheet

Low Profile Swing Clamps

SIZE A	IS1505	REV C
-----------	--------	----------

FORM FEG041-IS.AS1ZE, REV. B

C	2799	RELEASE	JDW	01/29/15
REV	IN ACCORDANCE WITH ECN	EFFECTIVE DATE	REVISED BY	DATE
DRW BY: MES	DRAWING STATUS: Released			
DATE: 08/01/05	PRODUCTION APPROVED FOR RELEASED STATUS ONLY			

SHEET 1 OF 1