

N/A	N/A	IS1008	INSTRUCTION SHEET			
N/A	N/A	61100521	KIT, SPRING			
N/A	N/A	6V100520	KIT, SEAL, FKM			
N/A	N/A	60100520	KIT, SEAL, STANDARD			
8	1	39V51020	O-RING, (-018)	X	X	
7	1	39V11057	WIPER, PRESS-IN, (2)	X	X	
6	1	81042002	STUD, SPRING, WS, AA, 12500/55KN			
5	1	81042000	BASE, WS, SPR8AA, 12500			
4	1	81021501	RETAINER, WS, SPR8AA, 12500			
3	1	39001030	O-RING, (-147)	X	39V01030	
2	1	39001028	O-RING, (-136)	X	39V01028	
1	1	23313012	SPRING, COMPRESSION			X
No.	QTY	PART No.	DESCRIPTION	Included in Std. Seal Kit	Included in FKM Seal Kit	Included in Spring Kit

APPLY LUBRICANT TO ALL SEALS PRIOR TO INSTALLATION
DO NOT USE SILICONE TYPE LUBRICANTS.

PARTS LIST



VEKTEK, INC.
1334 E. SIXTH AVE. P.O. BOX 625
EMPORIA, KS. 66801 U.S.A.

B	2965	RELEASE	JDW	01/09/16
REV	IN ACCORDANCE WITH ECN	EFFECTIVE DATE	REVISED BY	DATE
DRW BY:	JDW	DRAWING STATUS: Released		
DATE:	3-8-07	PRODUCTION APPROVED FOR RELEASED STATUS ONLY		

ASSEMBLIES AFFECTED
10062007
10062007F

PARTS LIST, ASSY, WS, AA, BM, 12500, TOP RET		
SIZE A	PL1052	REV B

FORM FEG035_PL_AS1ZE, REV. B

SHEET 1 OF 1

Vekttek, Inc. 1334 East Sixth Ave. P.O. Box 625 Emporia, Ks. 66801 U.S.A.	Instruction Sheet	IS-	1008		
		REV:	B, I.A.W. ECN2964		
		BY/DATE:	JDW	01/11/16	
		APPR/DATE:	GY	02/10/16	
Title Assembly/Disassembly:7500 & 12500 Air Advance Work Supports, Top Retainer					

Read all instructions before disassembly.

Refer to the illustration on page three for component item numbers and a tool list.

Disassembly

Notice: When disassembling multiple work supports, the plunger and body/sleeve assembly from each work support should be kept together.

To Remove Spring and Spring Retainer Seal

1. Clamp the work support base (1) in a vise.
2. With an open-end wrench on the plunger (2) and a flat blade screwdriver in the slot on the spring retainer (3) unthread. Remove the spring retainer and spring retainer seal (10) from the plunger.
3. Unthread and remove the spring stud (4).
4. Remove the spring (5).

To Remove Plunger Wiper

1. Clamp the work support base (1) in a vise.
2. With an open-end wrench on the plunger (2) and a flat blade screwdriver in the slot on the spring retainer (3) unthread and remove the spring retainer from the plunger.
3. Unthread and remove the spring stud (4).
4. Remove the spring (5).
5. Remove the plunger (2).
6. Remove wiper (6) from the body/sleeve assembly (7).

Caution: Do not scratch the inner sleeve.

7. Clean all parts thoroughly and set aside to dry.

To Remove O-rings

1. Clamp the work support base (1) in a vise
2. Unthread the body/sleeve assembly (7) from the base (1) and slide it off the plunger (2).

Caution: Use a six-point socket only. Other types of wrenches may damage the work support.

3. Remove the o-rings (8) & (9).
4. Clean all parts thoroughly and set aside to dry.

Vekttek, Inc. 1334 East Sixth Ave. P.O. Box 625 Emporia, Ks. 66801 U.S.A.	Instruction Sheet	IS-	1008		
		REV:	B, I.A.W. ECN2964		
		BY/DATE:	JDW	01/11/16	
		APPR/DATE:	GY	02/10/16	
Title Assembly/Disassembly:7500 & 12500 Air Advance Work Supports, Top Retainer					

Assembly

To Assemble Spring and Spring Retainer Seal

1. Insert the spring (5) into the plunger (2).
2. Insert the spring stud (4) through the plunger (2) and tighten it to the base (1) to the torque specification on the parts list.
3. Install the spring retainer seal (10) into the threaded hole in the plunger (2). Install the spring retainer (3) into the threaded hole in the plunger (2) and with an open-end wrench on the plunger and a flat blade screwdriver in the slot on the spring retainer tighten the spring retainer to the torque specification on the parts list.

To Assemble Wiper

1. Insert the wiper (6) into the body/sleeve assembly (7).
2. Insert the plunger (2) into the body/sleeve assembly (7).
3. Insert the spring (5) into the plunger (2).
4. Insert the spring stud (4) through the plunger (2) and tighten it to the base (1) at the torque specification on the parts list.
5. Install the spring retainer (3) into the threaded hole in the plunger (2) and with an open-end wrench on the plunger and a flat blade screwdriver in the slot on the spring retainer tighten the spring retainer to the torque specification on the parts list.

To Assemble O-rings

1. Lubricate all o-rings with clean hydraulic fluid. (Vekttek 65-0010-01 or equivalent).
2. Place the o-rings (8) & (9) in their respective places in the base (1).
3. Position the body/sleeve assembly (7) over the plunger (2), press it down to the base (1) and tighten it to the torque specification on the parts list. **Note: Make certain the o-rings have not moved out of position. Caution-Use a six-point socket only. Other types of wrenches may damage the work support.**

Vekttek, Inc. 1334 East Sixth Ave. P.O. Box 625 Emporia, Ks. 66801 U.S.A.	Instruction Sheet	IS- 1008	
		REV: B, I.A.W. ECN2964	
		BY/DATE: JDW	01/11/16
		APPR/DATE: GY	02/10/16
Title Assembly/Disassembly:7500 & 12500 Air Advance Work Supports, Top Retainer			

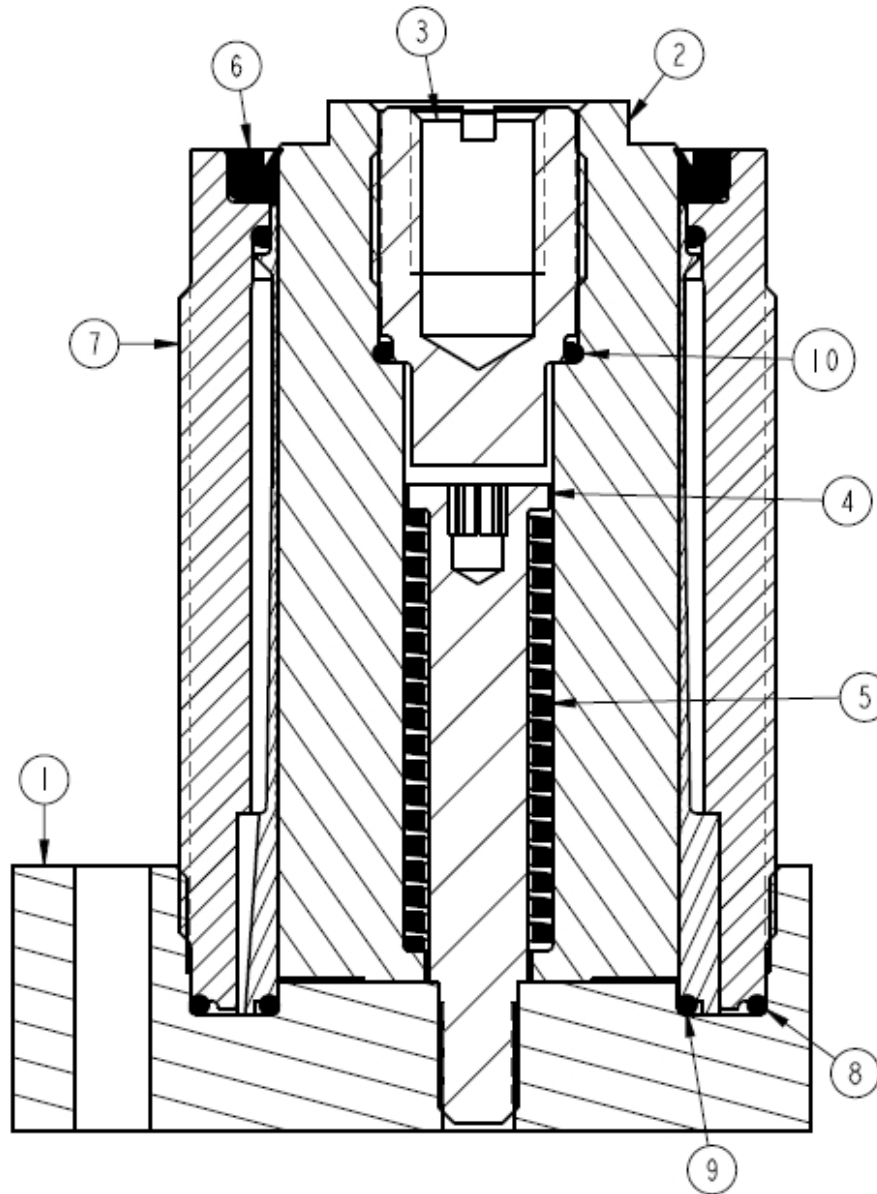

Model Number	Tools needed
10-0615-06	2 socket (six pt), 3/16 hex key, 1 1/8 open-end wrench, 11/16 wide flat blade screwdriver
10-0620-07	2 3/4 socket (six pt), 3/16 hex key, 1 5/8 open-end wrench, 13/16 wide flat blade screwdriver