

LUBRICATE ALL SEALS WITH CLEAN HYDRAULIC OIL PRIOR TO ASSEMBLY.
DO NOT USE SILICONE BASED LUBRICANTS.

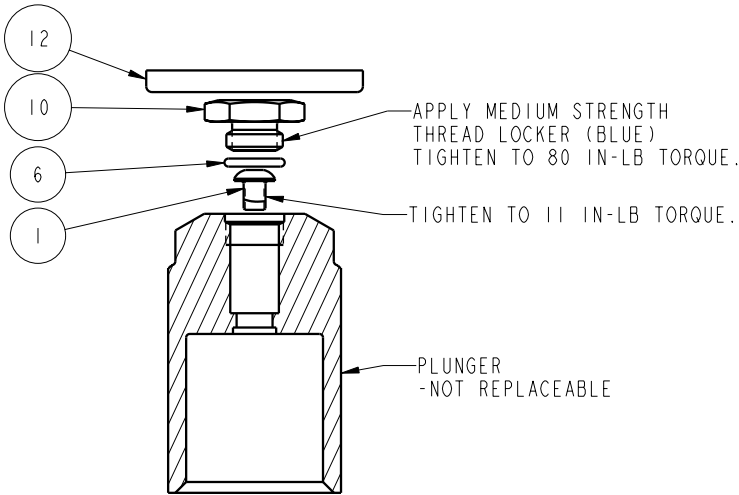

PLUNGER
-NOT REPLACEABLE

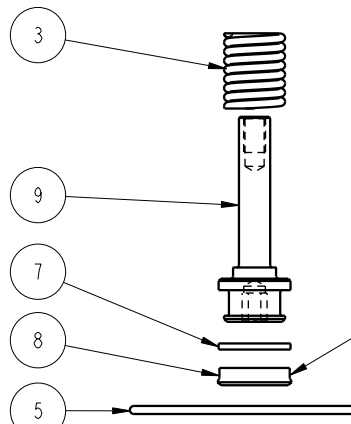
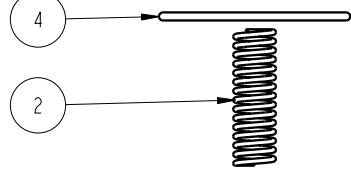
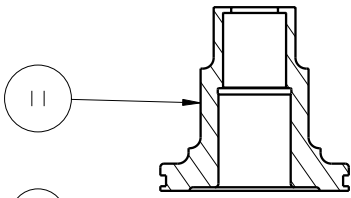
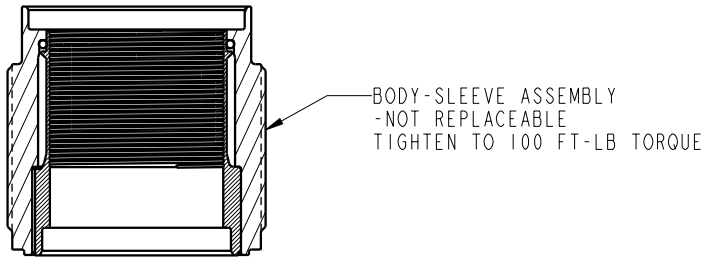

N/A	N/A	1S1012	INSTRUCTION SHEET, WS, FA, 4000 & 17KN			
N/A	N/A	61100117	SPRING KIT, WS, FA, 4000 & 17KN			
N/A	N/A	6V100117	SEAL KIT, WS, FA, 4000 & 17KN, FKM			
N/A	N/A	60100117	SEAL KIT, WS, FA, 4000 & 17KN			
12	1	39V11051	WIPER, PRESS-IN, 1-1/2", 85 FKM	X	X	
11	1	81041508	RETAINER, WS, FA, 4000 & 17 KN			
10	1	81041505	BOLT, CONTACT, WS, FA, 4000			
9	1	81011506	PISTON, WS, FA, 4000 & 17 KN			
8	1	39052028	SEAL, BEV, 7/16x3/32x5/8, 85 HNBR	X	39052014	
7	1	39010072	BU RING, (-111), PFTE, CUT	X	X	
6	1	39002009	O-RING, (-012), .364x.070, 70 NBR	X	X	
5	1	39001022	O-RING, 2-1/16 x 1/16, 90 AUD	X	39V01022	X
4	1	39001009	O-RING, (-029), 1.489x.07, 90 AU	X	39V01009	
3	1	23350063	SPRING, COMP., .530x.070x1.453x.578, 54.2			X
2	1	23350061	SPRING, COMP., .371x.045x2.512x.678, 12.4			X
1	1	21410077	BHCS, 10-32 x 1/4 SELFLOCK, SST			
No.	QTY	PART No.	DESCRIPTION	Std. Seal Kit	FKM Seal Kit	Spring Kit

PARTS LIST



VEKTEK, INC.
1334 E. SIXTH AVE. P.O. BOX 625
EMPORIA, KS. 66801 U.S.A.

ASSEMBLIES AFFECTED

10071506
10071506F

PARTS LIST, ASSY, WS, FA, CM, 4000

SIZE
A

PL1065

REV
C

C	2505	RELEASE	JDW	04/18/13
REV	IN ACCORDANCE WITH ECN	EFFECTIVE DATE	REVISED BY	DATE
DRW BY:	JDW	DRAWING STATUS: Released		
DATE:	9-7-07	PRODUCTION APPROVED FOR RELEASED STATUS ONLY		

FORM FEG035_PL_ASIZE, REV. A

SHEET 1 OF 1

Vekttek Inc. 1334 East Sixth Ave. P.O. Box 625 Emporia, Ks. 66801 U.S.A.	Instruction Sheet	IS1012		
		REV.	C I.A.W. ECN2168	
		BY/DATE:	JDW	5-3-10
		APPR/DATE:	JAM	5-20-10
Title: Disassembly/Assembly: 4000 lb & 17 kN Fluid Advance Work Support				

Read all instructions before disassembly

Refer to the illustration on page three for the component numbers and a tool list.

Disassembly

Notice: When disassembling multiple work supports, the plunger and body/sleeve assembly from each work support should be kept together.

1. Clamp the work support base (13) or feeder cap in a vise. Cartridge mounted work supports should remain in their fixture for step two.
2. Remove the contact bolt (1) from the plunger (3). Remove o-ring (15) from contact bolt (1).
3. Remove the body/sleeve assembly (2) from the base (13), feeder cap or fixture.
Caution--Use a six-point socket only. Other types of wrenches may damage the work support.
4. Remove the cap screw (4) from the piston (5). A 3/16 hex key inserted into the bottom of the piston (5) will be needed to keep it from turning with the cap screw (4).
6. Pull the plunger (3) out of the body/sleeve assembly (2).
7. Remove the retainer (6) and piston (5) from the body/sleeve assembly (2).
8. Remove the springs (7) & (8). Remove the seal (10) from the piston (5).
9. Remove the wiper (9) from the body/sleeve assembly (2). **Caution--Do not scratch the inner sleeve of the body/sleeve assembly (2).**
10. Remove the O-ring (12) from base (13), feeder cap or fixture. Remove the O-ring (11) from the retainer (6).
11. Clean all parts thoroughly and set aside to dry.

Vekttek Inc. 1334 East Sixth Ave. P.O. Box 625 Emporia, Ks. 66801 U.S.A.	Instruction Sheet	IS1012		
		REV.	C I.A.W. ECN2168	
		BY/DATE:	JDW	5-3-10
		APPR/DATE:	JAM	5-20-10
Title: Disassembly/Assembly: 4000 lb & 17 kN Fluid Advance Work Support				

Assembly

1. Lubricate the seal (10) and O-rings (11) & (12) with clean hydraulic oil (Vekttek 65-0010-01 or equivalent). Apply Loctite primer N® or equivalent to the threads of the contact bolt (1) and allow to dry.
2. Press the new wiper (9) into the body/sleeve assembly (2). Use only enough force to seat the wiper into the counterbore. **Caution--Excess force may cause the inner sleeve to collapse.**
3. Install the O-ring (11) into the groove of the retainer (6).
4. Insert the retainer (6) into the body/sleeve assembly (2) from the bottom. Insert the plunger (3) into the body/sleeve assembly (2) from the top.
5. Install the seal (10) onto the piston (5) with the open side of the seal toward the bottom end of the piston (5).
6. Install the springs (7) & (8) onto the piston (5).
7. Insert the piston (5) and springs (7) & (8) into the retainer (6).
8. Screw the cap screw (4) into the piston (5). Tighten to the torque specification on the parts list. A 3/16 hex wrench inserted into the bottom of the piston (5) will be needed to keep the piston (5) from turning with the cap screw (4).
9. Place the O-ring (12) into the bottom of the cavity in the base (13), feeder cap or fixture.
10. Screw the work support assembly into the base (13), feeder cap or fixture. The assembly will come to a positive stop when it contacts the mating surface. Tighten to the torque specification on the parts list. **Caution--Use a six-point socket only. Other types of wrenches may damage the work support.**
11. Install o-ring (15) onto contact bolt (1). Apply medium strength Loctite 243® or equivalent to the threads of the contact bolt (1) and screw the contact bolt (1) into the plunger (3). Tighten to the torque specification on the parts list.

Vekttek Inc. 1334 East Sixth Ave. P.O. Box 625 Emporia, Ks. 66801 U.S.A.	Instruction Sheet	IS1012	
		REV.	C I.A.W. ECN2168
		BY/DATE:	JDW 5-3-10
		APPR/DATE:	JAM 5-20-10
Title: Disassembly/Assembly: 4000 lb & 17 kN Fluid Advance Work Support			

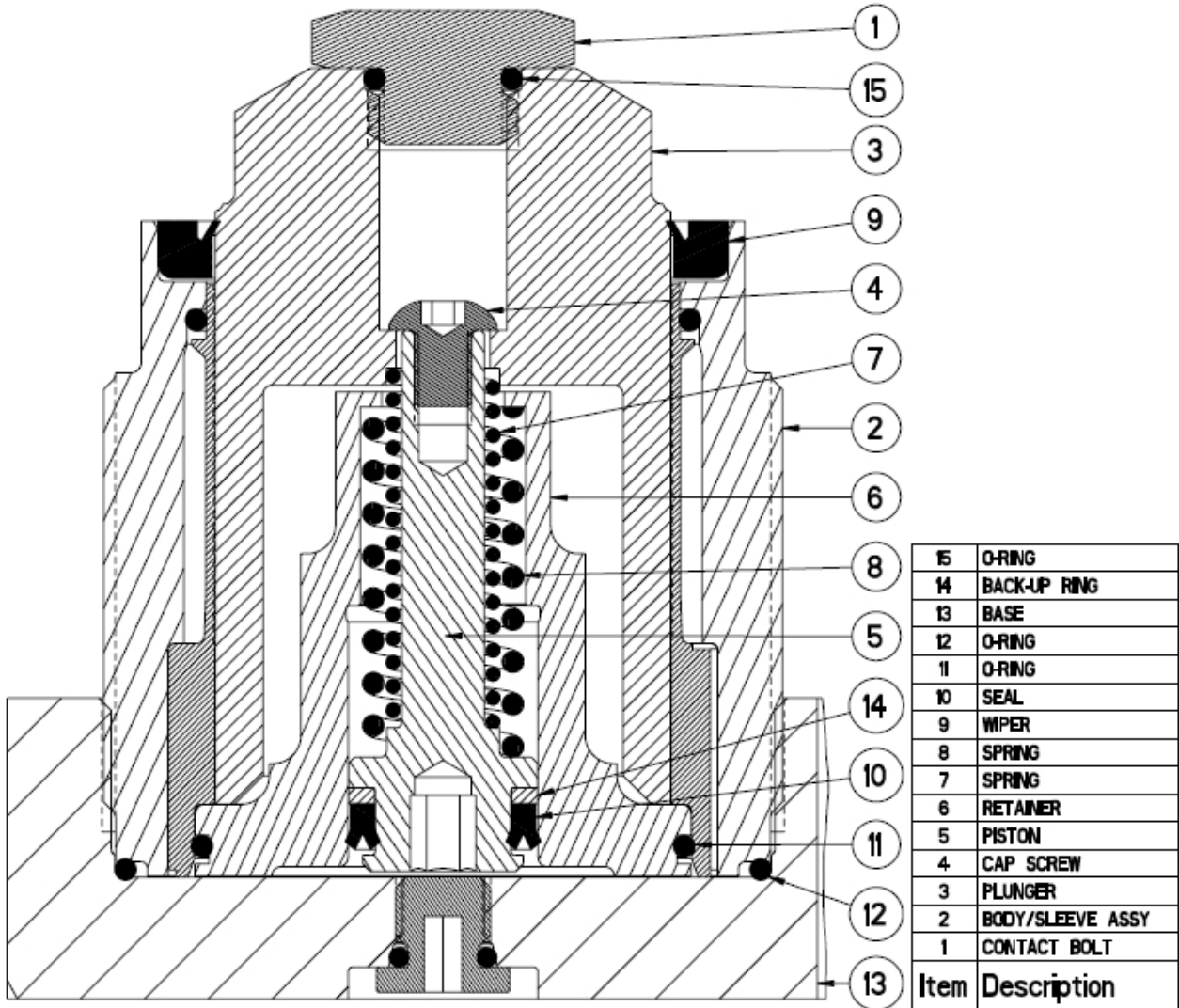

Model Number	Tool List
10071506 10081505 10081506	1/8 & 3/16 hex keys, 3/4 & 1-3/8 open end wrenches, 2 socket (6 pt)
41007105 41007005 6964H-17-1 6964H-17-2	1/8 & 3/16 hex keys, 18mm & 19mm open end wrenches, 30mm socket (6 pt)