

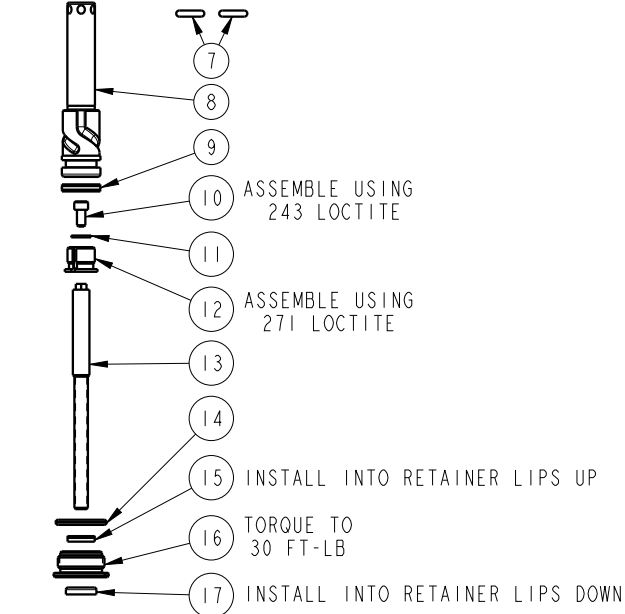

NO.	QTY.	DESCRIPTION			STANDARD SEAL KIT	FLUOROCARBON SEAL KIT
			14-2209-01-X-PR	14-2213-01-X-PR		
1	1	BUTTON HEAD CAP SCREW	21-4100-09	21-4100-39	NO	NO
2	1	WIPER, ROD (FLUOROCARBON)	39-0530-01	39-0530-00	YES	YES
3	1	BACK-UP RING, ROD	39-F540-01	39-F540-02	YES	YES
4	1	SEAL, ROD (STANDARD)	39-0100-20	39-0110-46	YES	NO
	1	SEAL, ROD (FLUOROCARBON)	39-V100-20	39-V110-46	NO	YES
5	3	BALL, TUNGSTEN CARBIDE	23-6500-03	23-6500-04	YES	YES
6	3	BALL SEAT ASSEMBLY	90-1999-57	90-1999-58	YES	YES
7	2	O-RING, MANIFOLD (STANDARD)	39-0000-50	39-0000-50	YES	NO
	2	O-RING, MANIFOLD (FLUOROCARBON)	39-0510-22	39-0510-22	NO	YES
8	1	PLUNGER, LEFT HAND (SHOWN)	81-4000-51	81-4000-52	NO	NO
	1	PLUNGER, RIGHT HAND	81-4000-48	81-4000-49	NO	NO
9	1	SEAL, PLUNGER (STANDARD)	39-H100-18	39-H110-30	YES	NO
	1	SEAL, PLUNGER (FLUOROCARBON)	39-V100-18	39-V110-30	NO	YES
10	1	SOCKET HEAD CAP SCREW	21-4100-73	21-4100-73	NO	NO
11	1	WASHER	23-0500-11	23-0500-11	NO	NO
12	1	PLUNGER BUSHING	81-5000-13	81-5000-14	NO	NO
13	1	ACTUATOR ROD	81-5005-08	81-5005-09	NO	NO
14	1	O-RING, RETAINER (FLUOROCARBON)	39-0510-31	39-V510-43	YES	YES
15	1	SEAL, LOADED LIP	39-0520-31	39-0520-31	YES	NO
	1	SEAL, LOADED LIP (FLUOROCARBON)	39-V520-36	39-V520-36	NO	YES
16	1	RETAINER	81-4000-53	81-4000-54	NO	NO
17	1	WIPER (FLUOROCARBON)	39-0530-23	39-0530-23	YES	YES
N/A	N/A	SEAL KIT (STANDARD)	60-1400-03	60-1400-04	INCLUDED IN KIT	
N/A	N/A	SEAL KIT (FLUOROCARBON)	6V-1400-03	6V-1400-04		

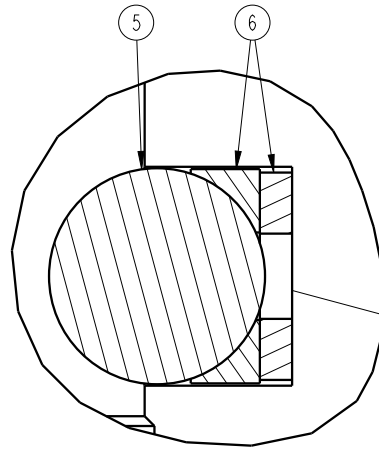
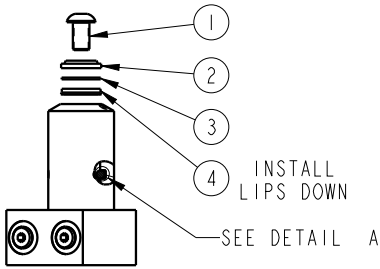

Lubricate all seals with clean hydraulic fluid prior to assembly.

<b>PARTS LIST</b>	 VEKTEK, INC. 1334 E. SIXTH AVE. P.O. BOX 625 EMPORIA, KS. 66801 U.S.A.
	<b>PARTS LIST, SC, BF, HS, DA, PR</b>
ASSEMBLIES AFFECTED 14-2209-01-L-PR, 14-2209-01-L-F-PR 14-2209-01-R-PR, 14-2209-01-R-F-PR 14-2213-01-L-PR, 14-2213-01-L-F-PR 14-2213-01-R-PR, 14-2213-01-R-F-PR	SIZE A
DRAWING STATUS: <b>Released</b> PRODUCTION APPROVED FOR RELEASED STATUS ONLY	REV E

E	3518	RELEASE	JDW	07/02/18
REV	IN ACCORDANCE WITH ECN	EFFECTIVE DATE	REVISED BY	DATE
DRW BY:	JAW	DRAWING STATUS: <b>Released</b> PRODUCTION APPROVED FOR RELEASED STATUS ONLY		
DATE:	03/10/05			