

LUBRICATE ALL SEALS WITH CLEAN HYDRAULIC OIL PRIOR TO ASSEMBLY.  
DO NOT USE SILICONE BASED LUBRICANTS.

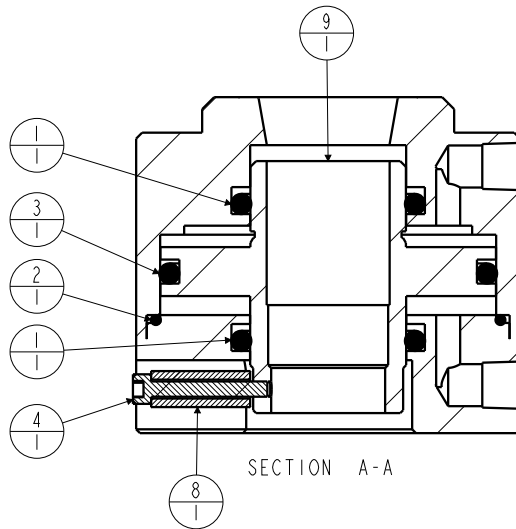

No.	QTY	PART No.	DESCRIPTION	Std. Seal Kit
N/A	N/A	60155400	SEAL KIT	NOTED
9	1	65-0009	PISTON	
8	1	65-0003	SLEEVE	
7	1	65-0002	BODY WITH ENCLOSURE RING	
6	1	65-0001	BASE	
5	4	01-2035-11	SHCS	
4	1	01-0058	SHCS	
3	1	39002007	O-RING, (-338)	X
2	1	39002006	O-RING, (-153)	X
1	2	39001053	O-RING, (-326)	X

### PARTS LIST

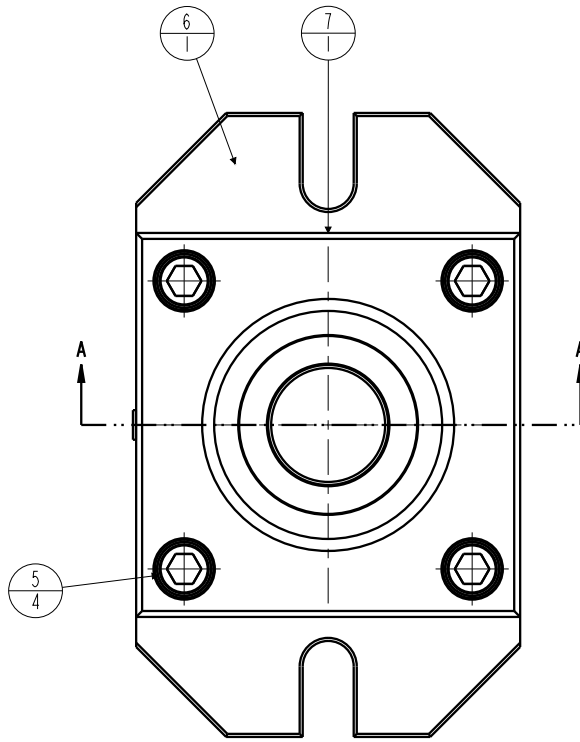

VEKTEK, INC.  
1334 E. SIXTH AVE. P.O. BOX 625  
EMPORIA, KS. 66801 U.S.A.

ASSEMBLIES AFFECTED  
15543501

PARTS LIST, ASSY, VISE, COLLET, PNEU, FLG MT

SIZE  
A PL1550

REV  
D

SHEET 1 OF 1

D	4258	RELEASE	JDW	09/03/20
REV	IN ACCORDANCE WITH ECN	EFFECTIVE DATE	REVISED BY	DATE
DRW BY:	JACOB	<b>DRAWING STATUS: Released</b>		
DATE:	03/09/93	PRODUCTION APPROVED FOR RELEASED STATUS ONLY		

FORM FEG035\_PL\_ASIZE, REV. B