

Lubricate all seals with clean hydraulic oil prior to assembly.
DO NOT USE SILICONE BASED LUBRICANTS.

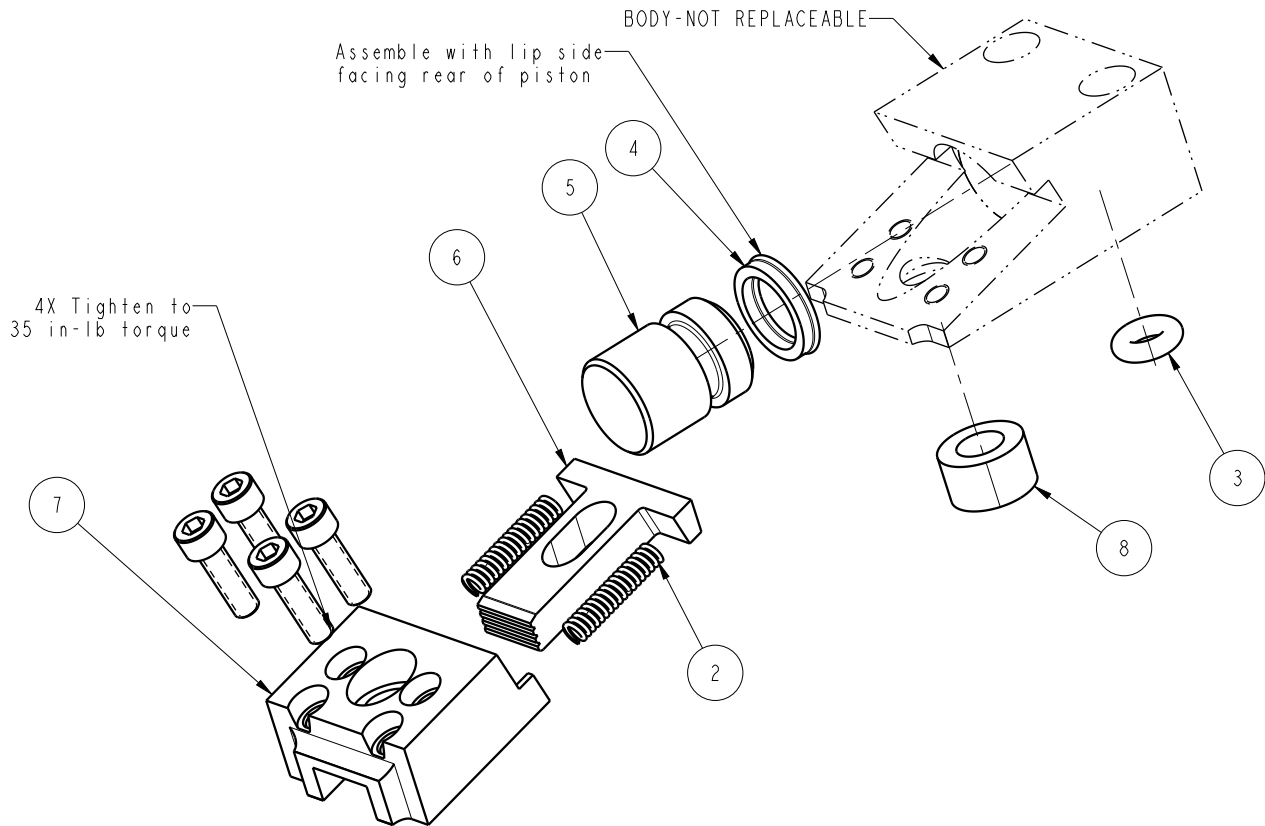

NO	QTY	PART NO	DESCRIPTION	REPAIR KIT	REPAIR KIT (FKM)
1	4	21411035	SCREW, CAP, SOCH, 10-32 X 5/8, ALY		
2	2	23310011	SPRING, COMPRESSION		
3	1	39000068	O-RING, (-202)	X	39V00068
4	1	39010013	SEAL, BEVEL, 9/16 X 3/32 X 3/4	X	39012000
5	1	81510800	PISTON, EDGE CLAMP, 2000		
6	1	81530800	BLADE, EDGE CLAMP, 2000		
7	1	81530801	CAP, EDGE CLAMP, 2000		
8	1	81540800	PIVOT, EDGE CLAMP, 2000		
N/A	N/A	62153004	KIT, REPAIR	NOTED	N/A
N/A	N/A	62153005	KIT, REPAIR, FKM	N/A	NOTED

PARTS LIST



VEKTEK, INC.
1334 E. SIXTH AVE. P.O. BOX 625
EMPORIA, KS. 66801 U.S.A.

ASSEMBLIES AFFECTED
15-3108-00

PARTS LIST, ASSY, EDGE CLAMP, 2000, MM

SIZE
A PL1554

REV
J

FORM FEG035_PL_ASIZE, REV. B

J	5075	RELEASE	RLK	4/21/23
REV	IN ACCORDANCE WITH ECN	EFFECTIVE DATE	REVISED BY	DATE
DRW BY: JACOB	DRAWING STATUS: Released			
DATE: 11/12/15	PRODUCTION APPROVED FOR RELEASED STATUS ONLY			

SHEET 1 OF 1