

LUBRICATE ALL SEALS WITH CLEAN HYDRAULIC OIL PRIOR TO ASSEMBLY. DO NOT USE SILICONE BASED LUBRICANTS.

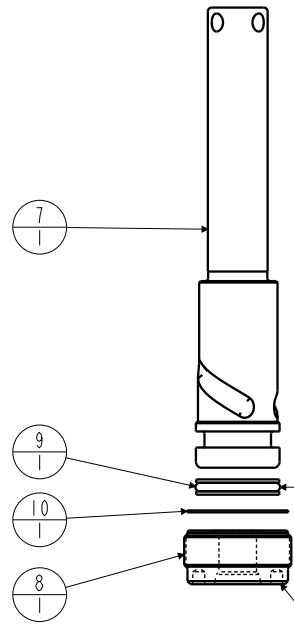

T-SEAL
INSTALLATION INFO

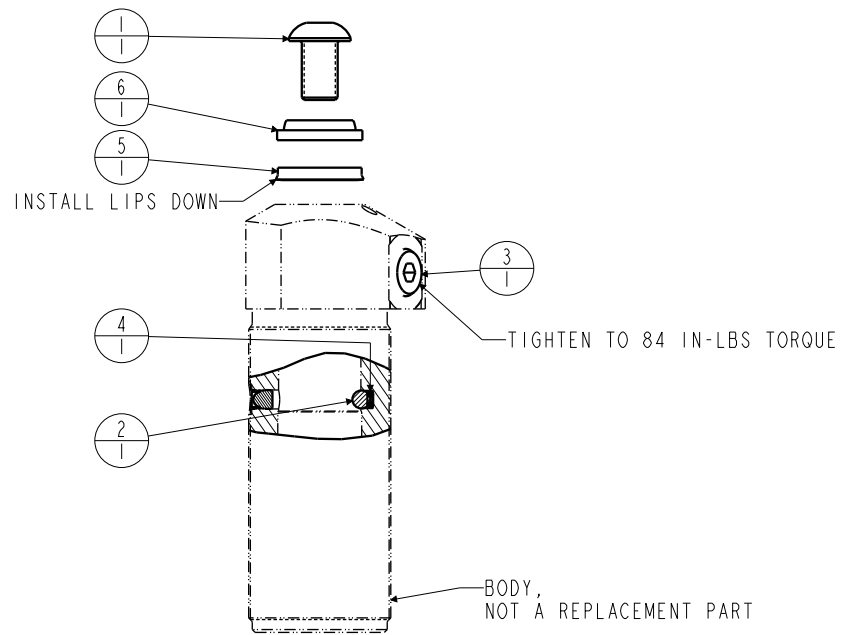
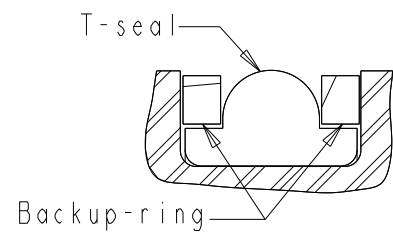
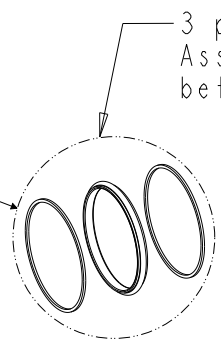

No.	QTY	PART No.	DESCRIPTION	Std. Seal Kit	FKM Seal Kit
N/A	N/A	6V150209	SEAL KIT, FKM		NOTED
N/A	N/A	60150209	SEAL KIT, STANDARD		NOTED
10	1	39T55002	GASKET, (-021)	X	X
9	1	39H10018	SEAL, T, (11/16 X 5/32 X 7/8)	X	39V10018
8	1	81530903	RETAINER, SC, DA, 1100, PORTED		
7	1	81510904	PLUNGER, SC, LS, 1100#		
6	1	39011023	WIPER, SNAP-IN, (5/8)	X	39053001
5	1	39010020	SEAL, BEVEL W/HEEL INSERT, 5/8 x 1/8 x 7/8	X	39V10020
4	1	39000019	O-RING, (-003)	X	39051006
3	1	30601144	PLUG, SOCH, SAE 4		
2	1	23600011	BALL, STEEL, ALLOY, .187	X	X
1	1	21410009	BHCS, 3/8-24 x 5/8, ALY		

1.230 TOTAL STROKE
.765 VERTICAL STROKE
.465 SWING STROKE
90° LH or RH SWING and STRAIGHT
VersaCam PLUNGER

(WEIGHT 2.18 LBS)

PARTS LIST



VEKTEK, INC.
1334 E. SIXTH AVE. P.O. BOX 625
EMPORIA, KS. 66801 U.S.A.

ASSEMBLIES AFFECTED
15020912

PARTS LIST, ASSY, SC, TB, DA, LS, 1100, BP, 90°, .757 VERT

SIZE A PL1567 REV G

G	4312	RELEASE	JDW	03/18/21
REV	IN ACCORDANCE WITH ECN	EFFECTIVE DATE	REVISED BY	DATE
DRW BY:	BUSH	DRAWING STATUS: Released		
DATE:	08/03/96	PRODUCTION APPROVED FOR RELEASED STATUS ONLY		

FORM FEG035_PL_ASIZE, REV. B

SHEET 1 OF 1