

Lubricate all seals with clean hydraulic fluid prior to assembly.  
Do not use silicone based lubricants.

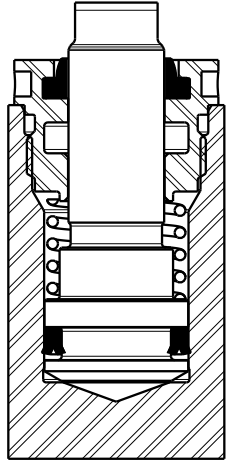
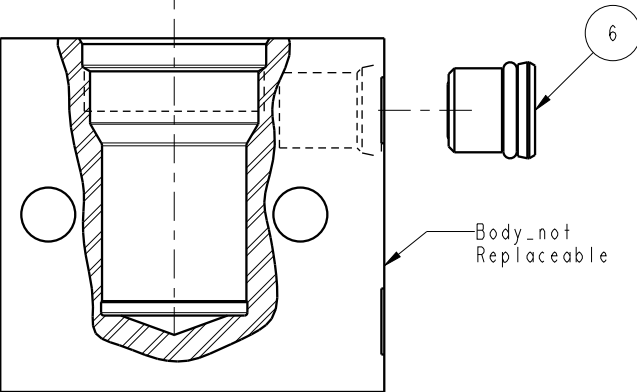
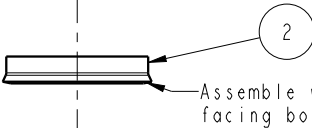
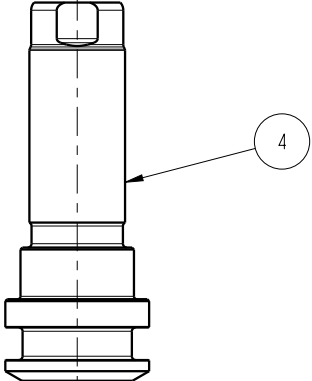
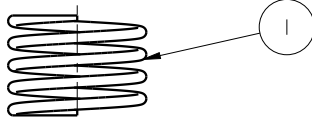
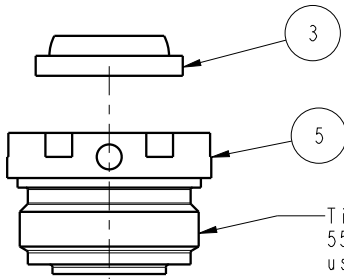

Standard Seal Kit 60-2011-08	Fluorocarbon Seal Kit 6V-2011-08	Spring Kit 61-2003-08
39-0100-13	39-0120-00	23-3130-07
39-0110-17	39-0120-11	

No.	QTY	PART No.	DESCRIPTION
6	1	92090001	ASSY, BREATHER, SAE #4
5	1	82030802	GLAND, CYL, BB, DA, 2200
4	1	82010803	PISTON, CYL, BB, 2200, .25 STRK
3	1	39011017	WIPER, SNAP-IN, (1/2
2	1	39010013	SEAL, BEVEL, 9/16 X 3/32 X 3/4
1	1	23313007	SPRING, COMPRESSION

<b>PARTS LIST</b>	<b>VEKTEK</b> <small>VEKTEK, INC.          1334 E. SIXTH AVE. P.O. BOX 625          EMPORIA, KS. 66801 U.S.A.</small>	
	<b>Model Number</b> 20-1108-00 20-1108-00F	ASSY, CYL, BB, 2200, .25 STRK, SA
SIZE A	<b>PL-2043</b>	REV <b>G</b>

G	4701	RELEASE	RLK	6/6/22
REV	IN ACCORDANCE WITH ECN	EFFECTIVE DATE	REVISED BY	DATE
DRW BY:	JACOB	<b>DRAWING STATUS: Released</b> PRODUCTION APPROVED FOR RELEASED STATUS ONLY		
DATE:	7-6-90			