

LUBRICATE ALL SEALS WITH CLEAN HYDRAULIC OIL PRIOR TO ASSEMBLY. DO NOT USE SILICONE BASED LUBRICANTS.

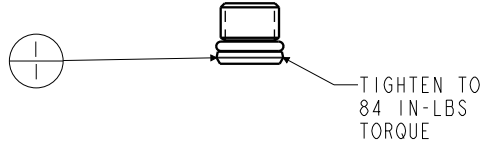
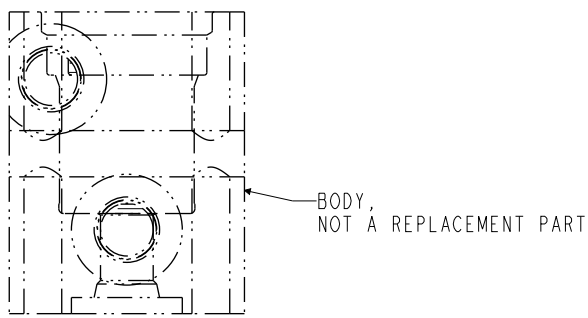
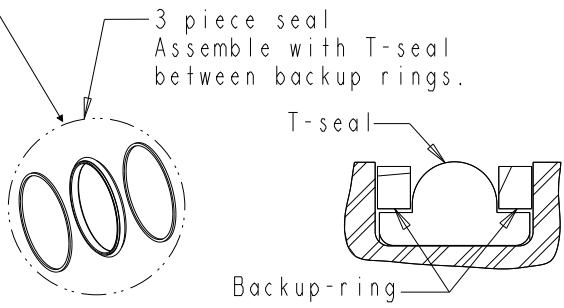
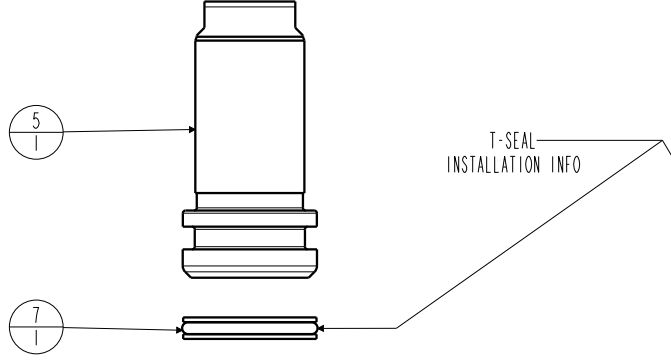
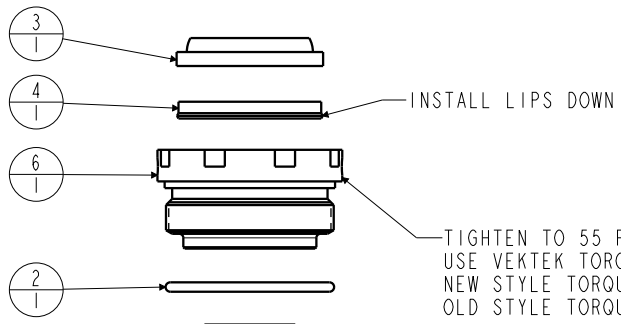

No.	QTY	PART No.	DESCRIPTION	Std. Seal Kit	FKM Seal Kit
N/A	N/A	6V200209	SEAL KIT, FKM		NOTED
N/A	N/A	60200210	SEAL KIT, STANDARD	NOTED	
7	1	39H10017	SEAL,T, (13/16 X 5/32 X 1)	X	39V10017
6	1	82031002	GLAND,CYL, 3900 & 17.8 KN		
5	1	82011004	PISTON,CYL,3900,.5 STRK		
4	1	39011045	SEAL, LL, (13/16 X 1/8 X 1/8 X 1-1/16)	X	39012005
3	1	39011018	WIPER,SNAP-IN, (13/16)	X	39012008
2	1	39001011	O-RING, (-024)	X	39012013
1	1	30601144	PLUG, SOCH, SAE 4		

PARTS LIST

(WEIGHT 1.96 LBS)

ASSEMBLIES AFFECTED
20121000
20121000F

VEKTEK
VEKTEK, INC.
1334 E. SIXTH AVE. P.O. BOX 625
EMPORIA, KS. 66801 U.S.A.

PL2054

FORM FEG035_PL_ASIZE, REV. B

PL2054

REV G

G	4312	RELEASE	JDW	04/18/21
REV	IN ACCORDANCE WITH ECN	EFFECTIVE DATE	REVISED BY	DATE
DRW BY:	JACOB	DRAWING STATUS: Released		
DATE:	08/06/90	PRODUCTION APPROVED FOR RELEASED STATUS ONLY		

SHEET 1 OF 1