

Lubricate all seals with clean hydraulic fluid prior to assembly.
Do not use silicone based lubricants.

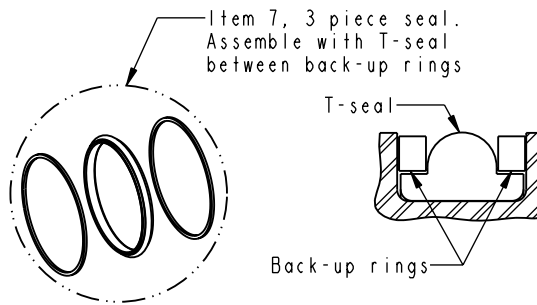
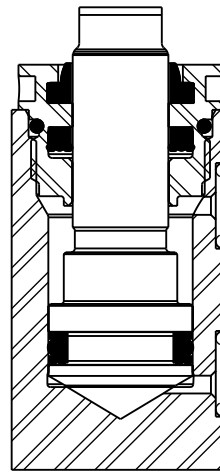
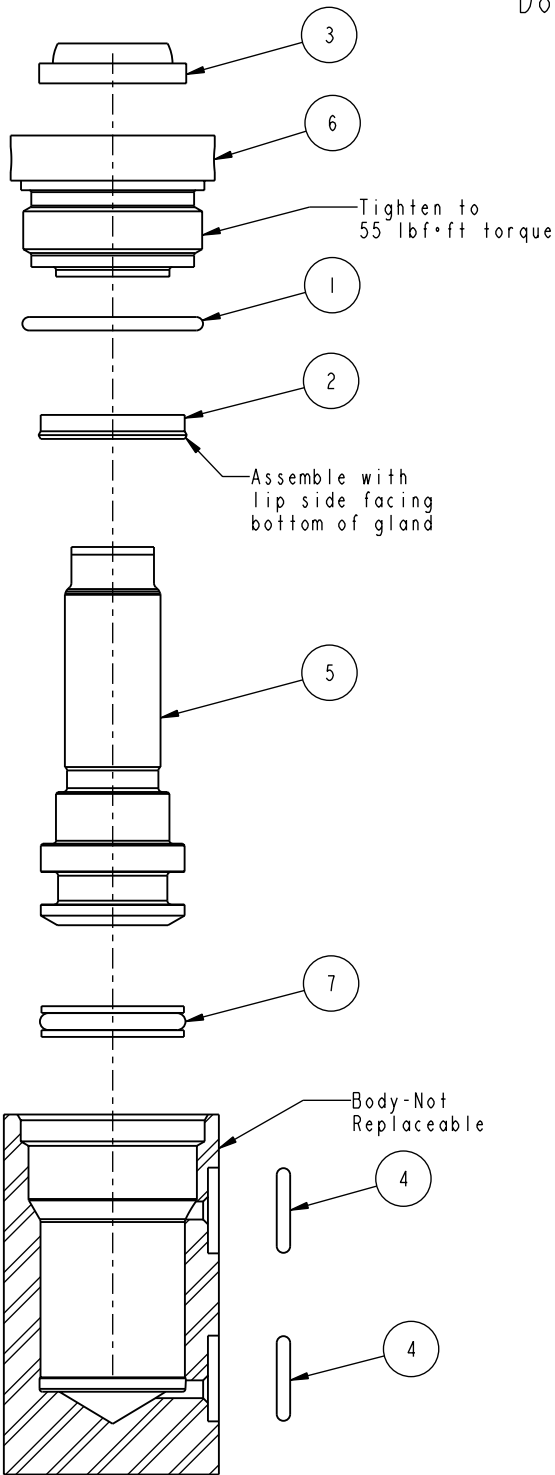

Standard Seal Kit	Fluorocarbon Seal Kit
60-2102-02	6V-2102-02
39-H100-16	39-V100-16
39-0500-42(2 ea)	39-0510-25(2 ea)
39-0000-13	39-0120-12
39-0100-19	39-0120-04
39-0110-17	39-0120-11

No.	QTY	PART No.	DESCRIPTION
7	1	39H10016	SEAL, T, PISTON, 9/16 X 5/32 X 3/4
6	1	82030802	GLAND, CYL, BB, DA, 2200
5	1	82010803	PISTON, CYL, BB, 2200, .25 STRK
4	2	39050042	O-RING
3	1	39011017	SEAL, WIPER, SNAP-IN, (1/2)
2	1	39010019	SEAL, LOADED LIP
1	1	39000013	O-RING

PARTS LIST



VEKTEK, INC.
1334 E. SIXTH AVE. P.O. BOX 625
EMPORIA, KS. 66801 U.S.A.

Model Number
21-1208-00
21-1208-00F

ASSY, CYL, BB, MM, 2200, .25 STRK, DA

SIZE
A

PL-2171

REV
E

FORM FEG035_PL_ASIZE, REV. A

E	2111	RELEASE	MES	10-19-09
REV	IN ACCORDANCE WITH ECN	EFFECTIVE DATE	REVISED BY	DATE
DRW BY:	JACOB	DRAWING STATUS: Released		
DATE:	3-13-00	PRODUCTION APPROVED FOR RELEASED STATUS ONLY		

SHEET 1 OF 1