

| NO | QTY | PART NO | DESCRIPTION | 21-4116-00 | 21-4116-01 | STD SEAL KIT |
|-----|-----|----------|---|------------|------------|--------------|
| 1 | 1 | 23355015 | SPRING, COMPRESSION | X | X | |
| 2 | 2 | 23520005 | PIN, SPRING, 1/4 X 7/8, SST | X | X | |
| 3 | 2 | 39051128 | O-RING, (-033) | X | X | X |
| 4 | 1 | 39052050 | SEAL, U-CUP, 1 3/8 x 3/16 x 1 3/4 | X | X | X |
| 5 | 1 | 39052054 | SEAL, LL, (7/8 X 1/8 X 1/8 X 1 1/8) | X | X | X |
| 6 | 1 | 39053054 | WIPER,PRESS-IN, (7/8) | X | X | X |
| 7 | 2 | 39054023 | BU RING,(-033) | X | X | X |
| 8 | 1 | 67010153 | TAG, INSTALL, CYL, CM, SLIP-IN | X | X | X |
| 9 | 1 | 82140014 | PLUNGER,CYL,CM,PULL,9000LB | X | | |
| - | 1 | 82140015 | PLUNGER,CYL,CM,PULL,9000LB | | X | |
| N/A | N/A | 64014210 | RETAINER, MNTG, CYL, CM, 9000LB | X | X | N/A |
| N/A | N/A | 60210118 | KIT, SEAL, CYL, CM, PULL, 9000LB | N/A | N/A | NOTED |
| N/A | N/A | IS2102 | INSTRUCTIONS, INSTALL, CYL, CM, SLIP-IN | N/A | N/A | N/A |

WHEN USED WITH RETAINING RING P/N 64-0142-10
TORQUE 3/8-16 BOLTS TO 24 FT-LBS

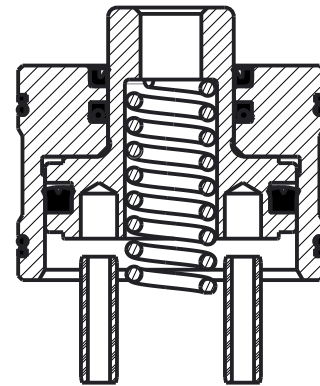
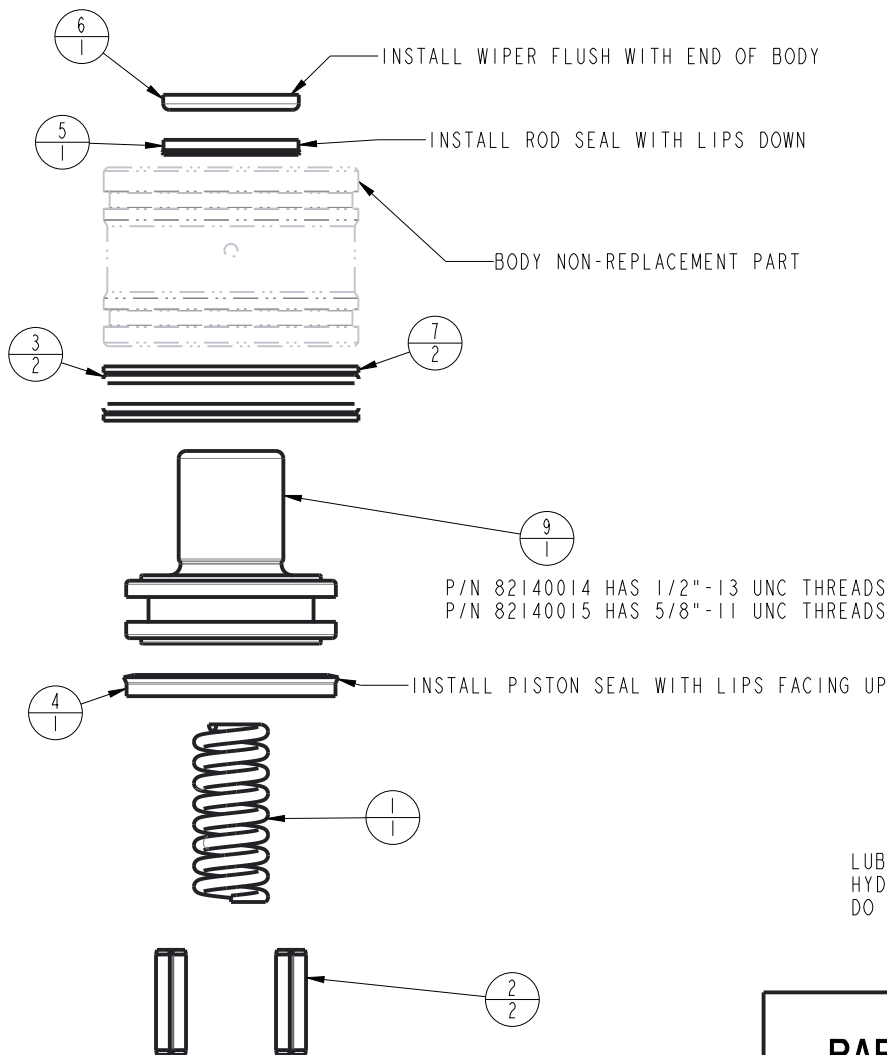

LUBRICATE ALL SEALS WITH CLEAN
HYDRAULIC OIL PRIOR TO ASSEMBLY
DO NOT USE SILICONE BASED LUBRICANTS

PARTS LIST



VEKTEK, INC.
1334 E. SIXTH AVE. P.O. BOX 625
EMPORIA, KS. 66801 U.S.A.

ASSEMBLIES AFFECTED
21-4116-00
21-4116-01

PARTS LIST, CYL, CM, PL DL, 9000LB

SLIP IN

SIZE
A

PL2185

REV
A

| | | | | |
|---------|------------------------|--|------------|---------|
| A | 2802 | RELEASE | DKC | 2/24/15 |
| REV | IN ACCORDANCE WITH ECN | EFFECTIVE DATE | REVISED BY | DATE |
| DRW BY: | DKC | DRAWING STATUS: Released | | |
| DATE: | 9/25/14 | PRODUCTION APPROVED FOR RELEASED STATUS ONLY | | |

FORM FEG035_PL_ASIZE, REV. B

SHEET 1 OF 1

CAVITY AND INSTALLATION INSTRUCTIONS

PLEASE READ PRIOR TO OPERATION

Cavity Forming

-It is recommended that all cavities be prepared using a ball hone such as a *Flex-Hone™. This will deburr and round sharp edges to prevent seal damage. The honing prepares cavity for cylinder installation.

-Intersecting feed holes should be adequately deburred and chamfered to prevent seal damage.

*Flex-hone™ is a registered trademark of:
 Brush Research Manufacturing Co. Inc.
 Los Angeles, CA, 323-261-2193
 Please Contact Brush Research for additional information.

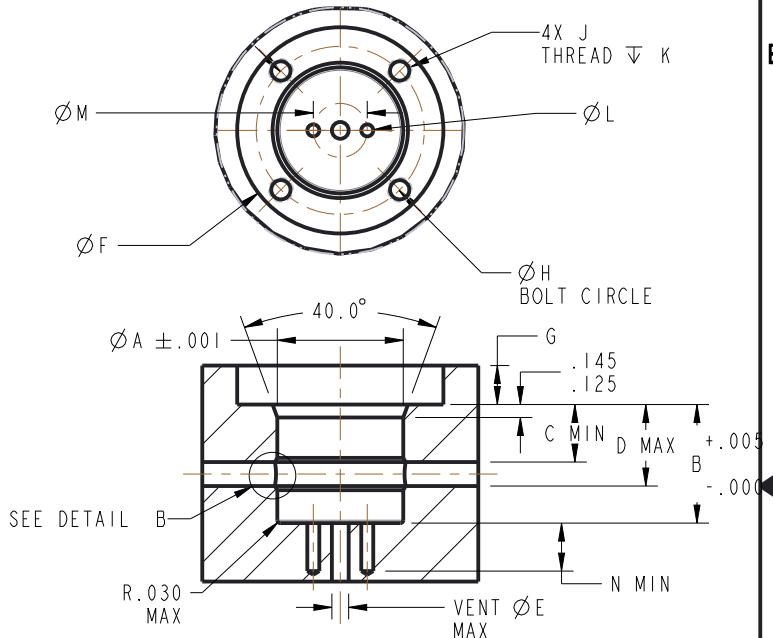
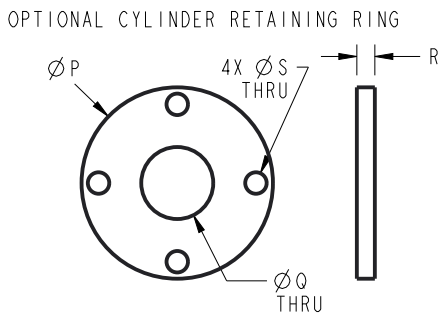
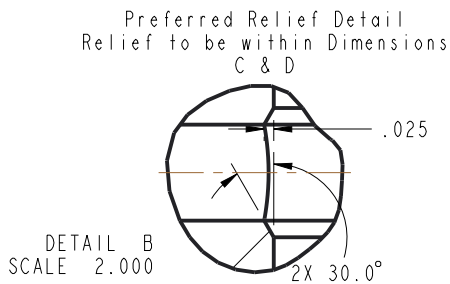

| MODEL NO. | CAPACITY | A | B | C | D | E | F | G | H | J | K | L* | M* | N* | P | Q | R | S |
|------------|----------|-------|-------|-----|------|-----|------|-----|------|-------------|-----|-----|------|-----|-------|------|------|------|
| 21-4106-XX | 980 | .813 | 1.120 | .44 | .72 | .16 | 1.40 | .31 | 1.13 | 8-32 UNC | .33 | .13 | .44 | .31 | 1.330 | .50 | .125 | .173 |
| 21-4109-00 | 2000 | 1.188 | 1.120 | .44 | .72 | .18 | 1.86 | .31 | 1.56 | 8-32 UNC | .33 | .13 | .53 | .40 | 1.832 | .75 | .125 | .173 |
| 21-4109-01 | 2000 | 1.188 | 1.245 | .44 | .84 | .18 | 1.86 | .31 | 1.56 | 8-32 UNC | .33 | .13 | .53 | .40 | 1.832 | .75 | .125 | .173 |
| 21-4111-XX | 2950 | 1.313 | 1.245 | .44 | .84 | .18 | 2.15 | .41 | 1.75 | 1/4-20 UNC | .38 | .13 | .56 | .40 | 2.125 | .75 | .125 | .257 |
| 21-4113-XX | 5200 | 1.751 | 1.370 | .44 | .97 | .33 | 2.83 | .53 | 2.31 | 5/16-18 UNC | .47 | .16 | .88 | .40 | 2.782 | 1.00 | .187 | .328 |
| 21-4116-XX | 9000 | 2.126 | 1.495 | .44 | 1.09 | .35 | 3.40 | .67 | 2.81 | 3/8-16 UNC | .50 | .28 | 1.00 | .60 | 3.375 | 1.12 | .250 | .391 |
| 21-4121-00 | 17100 | 2.876 | 1.620 | .44 | 1.22 | .40 | 4.59 | .90 | 3.81 | 1/2-13 UNC | .63 | .28 | 1.57 | .60 | 4.563 | 1.25 | .375 | .515 |

NOTE: CAVITY UTILIZES OPTIONAL RETAINING RING AVAILABLE FROM VEKTEK, INC.
 ADDITIONAL RETAINING RING INFORMATION IS CONTAINED IN SHEET 3.

*THESE FEATURES ARE ONLY NEEDED IF ANTI-ROTATION PINS ARE USED.

**ANTI-ROTATE PINS AND RETURN SPRINGS INCLUDED WITH CYLINDERS.

INSTALLATION INSTRUCTIONS



VEKTEK, INC.
 1334 E. SIXTH AVE. P.O. BOX 625
 EMPORIA, KS. 66801 U.S.A.

| | | | | |
|---------|------------------------|--|------------|---------|
| A | 2753 | RELEASE | DKC | 10/1/14 |
| REV | IN ACCORDANCE WITH ECN | EFFECTIVE DATE | REVISED BY | DATE |
| DRW BY: | DKC | DRAWING STATUS: Released | | |
| DATE: | 9/23/14 | PRODUCTION APPROVED FOR RELEASED STATUS ONLY | | |

ASSEMBLIES AFFECTED
 21-4106-XX 21-4109-XX
 21-4111-XX 21-4113-XX
 21-4116-XX 21-4121-00

| | |
|---|--------|
| INSTRUCTIONS, INSTALL, CTL, CH, SLIP-IN | |
| SLIP IN | REV A |
| SIZE A | IS2102 |

FORM FEG041-1S.AS1Z, REV. B

SHEET 1 OF 3

INSTALLATION INSTRUCTIONS CONTINUED

Installation Notes

- It is recommended that all cavities be prepared using a ball hone such as a *Flex-Hone™. This will deburr and round sharp edges to prevent seal damage and prepare cavity for cylinder installation.
- All seals should be lubricated with a non-silicone grease (recommended) or clean hydraulic oil prior to installation.

Installation

1. Lubricate all seals with non-silicone grease (recommended) or clean hydraulic oil.
2. Install return spring in plunger cavity with a small amount of grease to hold it in place during installation. See view below. A table of return spring part numbers is included below.

| Cylinder P/N | Return Spring P/N |
|--------------|-------------------|
| 21-4106-XX | 23-3550-11 |
| 21-4109-XX | 23-3550-12 |
| 21-4111-XX | 23-3550-12 |
| 21-4113-XX | 23-3550-14 |
| 21-4116-XX | 23-3550-15 |
| 21-4121-00 | 23-3550-16 |

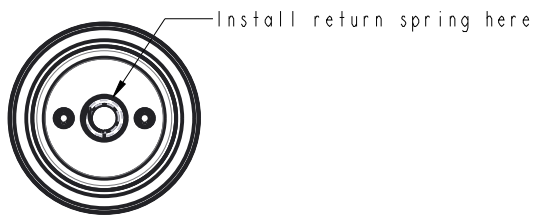

3. If using anti-rotate pins install a bolt and jam nut in plunger to help align pins. Press the piston end of the plunger even with end of body. See view below.

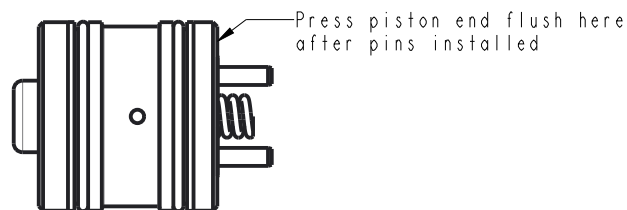

- a. Press cylinder into cavity until plunger begins to extend ensuring cylinder goes in evenly to prevent cavity or seal damage.
 - b. Using the bolt gently turn the plunger while applying slight downward force until plunger begins to retract. This ensures alignment of the anti-rotation pins.
 - c. Remove bolt and jam nut. Visually inspect spring through threaded hole in plunger to verify return spring is properly positioned.
4. Press cylinder body until flush with the start of the cavity. Stop if an increase in resistance is felt.
 - a. If using the optional retention ring, see chart below for proper torque.

| MODEL NO. | RETAINER NO. | BOLT SIZE | TORQUE |
|------------|--------------|-------------|------------------|
| 21-4106-XX | 64-0140-80 | 8-32 UNC | 29 IN-LBS |
| 21-4109-XX | 64-0141-10 | 8-32 UNC | 29 IN-LBS |
| 21-4111-XX | 64-0141-30 | 1/4-20 UNC | 63 IN-LBS |
| 21-4113-XX | 64-0141-70 | 5/16-18 UNC | 20 FT-LBS |
| 21-4116-XX | 64-0142-10 | 3/8-16 UNC | 24 FT-LBS |
| 21-4121-00 | 64-0142-80 | 1/2-13 UNC | 62 FT-LBS |

INSTALLATION INSTRUCTIONS



VEKTEK, INC.
1334 E. SIXTH AVE. P.O. BOX 625
EMPORIA, KS. 66801 U.S.A.

| | | | | |
|---------------|--|----------------|------------|---------|
| A | 2753 | RELEASE | DKC | 10/1/14 |
| REV | IN ACCORDANCE WITH ECN | EFFECTIVE DATE | REVISED BY | DATE |
| DRW BY: DKC | DRAWING STATUS: Released | | | |
| DATE: 9/23/14 | PRODUCTION APPROVED FOR RELEASED STATUS ONLY | | | |

| | | | |
|-----------------------|--|---------------|--------------|
| ASSEMBLIES AFFECTED | INSTRUCTIONS, INSTALL, CTL, CN, SLIP-IN | | |
| 21-4106-XX 21-4109-XX | SLIP IN | | |
| 21-4111-XX 21-4113-XX | SIZE | IS2102 | REV A |
| 21-4116-XX 21-4121-00 | A | | |