

LUBRICATE ALL SEALS WITH CLEAN HYDRAULIC OIL PRIOR TO ASSEMBLY.
DO NOT USE SILICONE BASED LUBRICANTS.

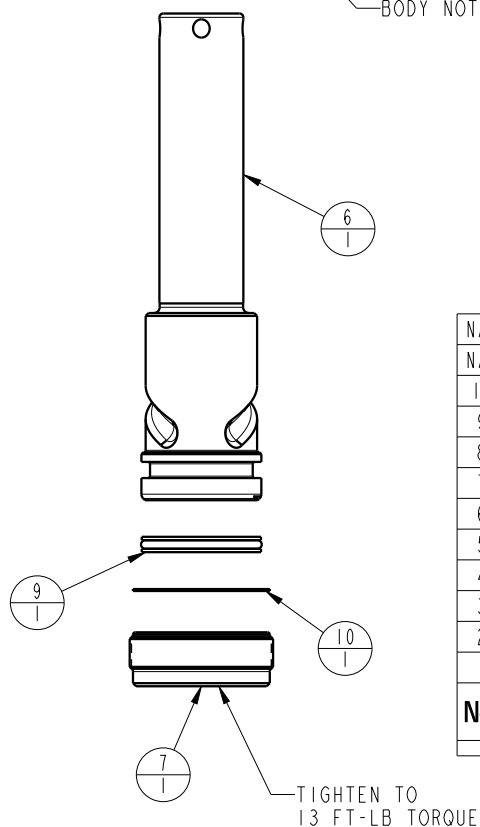

| | | | | | |
|------------|------------|-----------------|---|----------------------|---------------------|
| N/A | N/A | 6V251204 | SEAL KIT, FKM | N/A | NOTED |
| N/A | N/A | 60251204 | SEAL KIT, STANDARD | NOTED | |
| 10 | 1 | 39T55003 | GASKET, (-124) | X | X |
| 9 | 1 | 39H11030 | SEAL, T, (1 1/16X5/32X1 1/4) | X | 39V11030 |
| 8 | 1 | 39F54002 | BU RING, (-212 CUSTOM) | X | X |
| 7 | 1 | 81531302 | RETAINER, SC, DA, 2600, PORTED | | |
| 6 | 1 | 81511301 | PLUNGER, SC, 2600# | | |
| 5 | 1 | 39053000 | WIPER, SNAP-IN, (7/8) | X | X |
| 4 | 2 | 39021006 | BU RING, (-129) | X | 39011068 |
| 3 | 1 | 39011046 | SEAL, BEVEL W/HHEEL INSERT, 7/8 x 1/8 x 1 1/8 | X | 39V11046 |
| 2 | 1 | 39001040 | O-RING, (-924) | X | 39051029 |
| 1 | 1 | 39001039 | O-RING, (-129) | X | 39051028 |
| No. | QTY | PART No. | DESCRIPTION | Std. Seal kit | FKM Seal Kit |

PARTS LIST

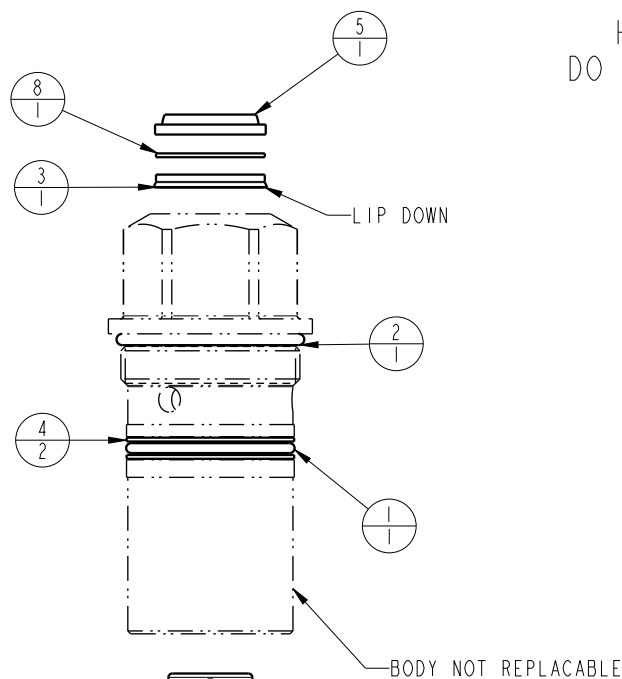

VEKTEK, INC.
1334 E. SIXTH AVE. P.O. BOX 625
EMPORIA, KS. 66801 U.S.A.

ASSEMBLIES AFFECTED

25121313

25121313F

PARTS LIST ASSY,CYL,PP,CM,6100/3100

SIZE
A

PL2522

REV
B

SHEET 1 OF 1

| | | | | |
|---------|------------------------|--|------------|---------|
| B | 4651 | RELEASE | RLK | 3/30/22 |
| REV | IN ACCORDANCE WITH ECN | EFFECTIVE DATE | REVISED BY | DATE |
| DRW BY: | RLK | DRAWING STATUS: Released | | |
| DATE: | 5/12/21 | PRODUCTION APPROVED FOR RELEASED STATUS ONLY | | |

FORM FEG035_PL_ASIZE, REV. B