

LUBRICATE ALL SEALS WITH CLEAN HYDRAULIC OIL PRIOR TO ASSEMBLY.
DO NOT USE SILICONE BASED LUBRICANTS.

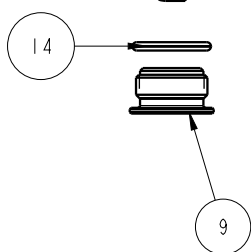

| N/A | N/A | 61250002 | SPRING KIT | N/A | N/A | NOTED |
|-----|-----|----------|--------------------------------|---------------|--------------|------------|
| N/A | N/A | 6V254102 | SEAL KIT, FKM | N/A | NOTED | |
| N/A | N/A | 60254102 | SEAL KIT, STANDARD | NOTED | | |
| 14 | 1 | 39V00036 | O-RING, (-908) | | | |
| 13 | 1 | 39F54000 | BU RING, (-111) | | | |
| 12 | 1 | 91590001 | ASSY, BREATHER, SAE 2 | | | |
| 11 | 1 | 81590501 | ROD, SUPPORT, SPRING, SC, 450 | | | |
| 10 | 1 | 81510500 | PLUNGER, SC, 450 | | | |
| 9 | 1 | 81400028 | RETAINER, SC, HS, 450 | | | |
| 8 | 1 | 39053004 | WIPER, SNAP-IN, (7/16) | | | |
| 7 | 1 | 39010038 | SEAL, BEVEL, 7/16 x 3/32 x 5/8 | X | 39052014 | |
| 6 | 1 | 39010036 | SEAL, BEVEL, 3/8 x 3/32 x 9/16 | X | 39052010 | |
| 5 | 2 | 30871120 | ASSY, ADAPTER, SC, TF, MM | X | 30871120F | |
| 4 | 3 | 30601122 | PLUG, SOCH, SAE 2 | | | |
| 3 | 1 | 23600014 | BALL, STEEL, ALLOY, .156 | | | |
| 2 | 1 | 23311017 | SPRING, COMPRESSION | | | X |
| 1 | 1 | 23310008 | SPRING, COMPRESSION | | | X |
| No. | QTY | PART No. | DESCRIPTION | Std. Seal kit | FKM Seal Kit | Spring Kit |

PARTS LIST

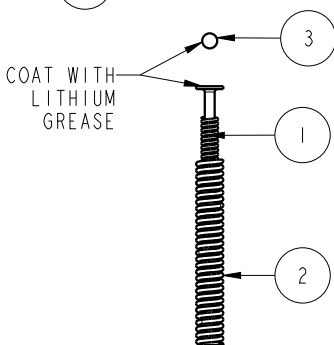
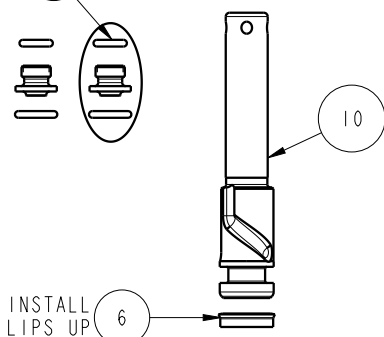
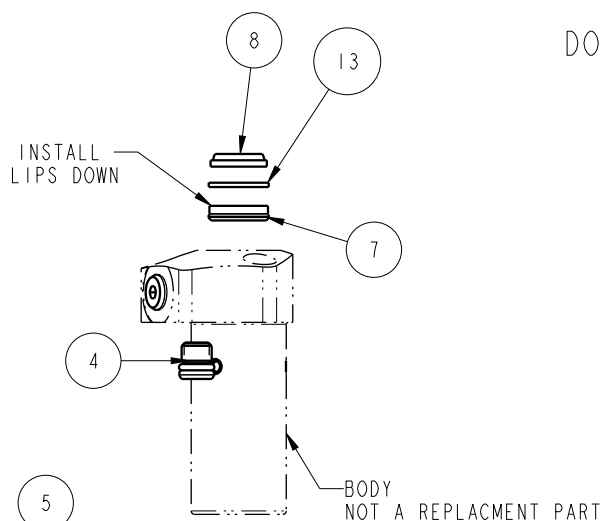

VEKTEK, INC.
1334 E. SIXTH AVE. P.O. BOX 625
EMPORIA, KS. 66801 U.S.A.

ASSEMBLIES AFFECTED
25610500
25610500F

PARTS LIST ASSY,CYL,PULL,TF,470

SIZE
A PL2523

REV
A

SHEET 1 OF 1

| | | | | |
|---------|------------------------|--|------------|----------|
| A | 4576 | RELEASE | RLK | 12/30/21 |
| REV | IN ACCORDANCE WITH ECN | EFFECTIVE DATE | REVISED BY | DATE |
| DRW BY: | RLK | DRAWING STATUS: Released | | |
| DATE: | 12/30/21 | PRODUCTION APPROVED FOR RELEASED STATUS ONLY | | |

FORM FEG035_PL_ASIZE, REV. B