

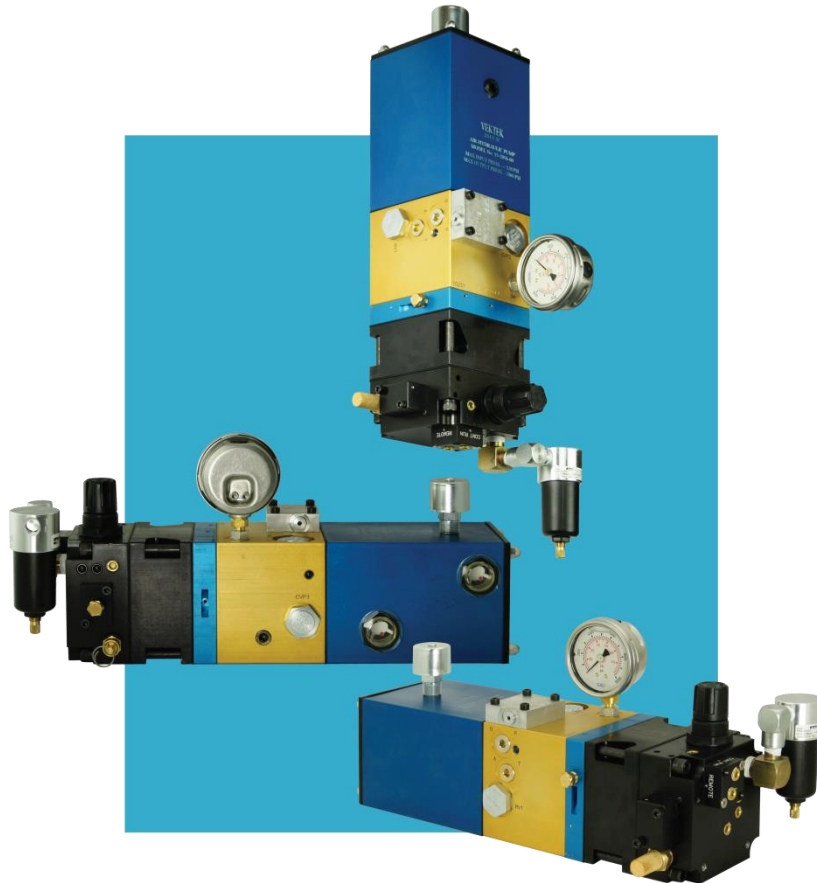

The Productivity Devices Company



**60:1
AIR HYDRAULIC PUMP
#55-2056-00**

VEKTEK, INC.
1334 EAST SIXTH AVENUE
EMPORIA, KANSAS 66801
1-800-992-0236



PL-5533 REV. AC, IAW ECN 5196

Safety Data Sheet

According to OSHA HCS 2012 (29 CFR 1910.1200)



SECTION 1: Identification

Product Identifier	Megaflow® AW Hydraulic Oil
Other means of identification	Phillips 66 Megaflow® AW Hydraulic Oil 22 Phillips 66 Megaflow® AW Hydraulic Oil 32 Phillips 66 Megaflow® AW Hydraulic Oil 46 Phillips 66 Megaflow® AW Hydraulic Oil 68 Phillips 66 Megaflow® AW Hydraulic Oil 100 Phillips 66 Megaflow® AW Hydraulic Oil 150 Phillips 66 Megaflow® AW Hydraulic Oil 220 Phillips 66 Megaflow® AW Hydraulic Oil 320
SDS Number	LBPH814637
Relevant identified uses	Hydraulic Fluid
Uses advised against	All others
24 Hour Emergency Phone Number	CHEMTREC 1-800-424-9300 CHEMTREC Mexico 01-800-681-9531

Manufacturer/Supplier	SDS Information	Customer Service
Phillips 66 Lubricants P.O. Box 4428 Houston, TX 77210	Phone: 800-762-0942 Email: SDS@P66.com URL: www.Phillips66.com	U.S.: 800-368-7128 or International: 1-832-765-2500 Technical Information 1-877-445-9198

SECTION 2: Hazard identification

Classified Hazards	Hazards Not Otherwise Classified (HNOC)
This material is not hazardous under the criteria of the Federal OSHA Hazard Communication Standard 29CFR 1910.1200.	PHNOC: None known HHNOC: None known

Label Elements
No classified hazards

SECTION 3: Composition/information on ingredients

Chemical Name	CASRN	Concentration ¹
Distillates, petroleum, hydrotreated heavy paraffinic	64742-54-7	>99

¹ All concentrations are percent by weight unless ingredient is a gas. Gas concentrations are in percent by volume.

SECTION 4: First aid measures

Eye Contact: If irritation or redness develops from exposure, flush eyes with clean water. If symptoms persist, seek medical attention.

Skin Contact: First aid is not normally required. However, it is good practice to wash any chemical from the skin. If product is injected into or under the skin, or into any part of the body, regardless of the appearance of the wound or its size, the individual should be evaluated immediately by a physician. (see Note to Physician)

Inhalation: First aid is not normally required. If breathing difficulties develop, move victim away from source of exposure and into fresh air in a position comfortable for breathing. Seek immediate medical attention.

Ingestion: First aid is not normally required; however, if swallowed and symptoms develop, seek medical attention.

Most important symptoms and effects, both acute and delayed: Inhalation of oil mists or vapors generated at elevated temperatures may cause respiratory irritation. Accidental ingestion can result in minor irritation of the digestive tract, nausea and diarrhea.

Notes to Physician: Acute aspirations of large amounts of oil-laden material may produce a serious aspiration pneumonia. Patients who aspirate these oils should be followed for the development of long-term sequelae. Inhalation exposure to oil mists below current workplace exposure limits is unlikely to cause pulmonary abnormalities. When using high-pressure equipment, injection of product under the skin can occur. In this case, the casualty should be sent immediately to the hospital. Do not wait for symptoms to develop. High-pressure hydrocarbon injection injuries may produce substantial necrosis of underlying tissue despite an innocuous appearing external wound. These injuries often require extensive emergency surgical debridement and all injuries should be evaluated by a specialist in order to assess the extent of injury. Early surgical treatment within the first few hours may significantly reduce the ultimate extent of injury.

SECTION 5: Firefighting measures

NFPA 704 Hazard Class

Health: 0 Flammability: 1 Instability: 0



0 (Minimal)
1 (Slight)
2 (Moderate)
3 (Serious)
4 (Severe)

Extinguishing Media: Dry chemical, carbon dioxide, foam, or water spray is recommended. Water or foam may cause frothing of materials heated above 212°F / 100°C. Carbon dioxide can displace oxygen. Use caution when applying carbon dioxide in confined spaces. Simultaneous use of foam and water on the same surface is to be avoided as water destroys the foam.

Specific hazards arising from the chemical

Unusual Fire & Explosion Hazards: This material may burn, but will not ignite readily. If container is not properly cooled, it can rupture in the heat of a fire.

Hazardous Combustion Products: Combustion may yield smoke, carbon monoxide, and other products of incomplete combustion. Oxides of sulfur, nitrogen or phosphorus may also be formed.

Special protective actions for firefighters: For fires beyond the initial stage, emergency responders in the immediate hazard area should wear protective clothing. When the potential chemical hazard is unknown, in enclosed or confined spaces, a self contained breathing apparatus should be worn. In addition, wear other appropriate protective equipment as conditions warrant (see Section 8).

Isolate the hazard area and deny entry to unnecessary and unprotected personnel Stop spill/release if it can be done safely. Move undamaged containers from immediate hazard area if it can be done safely Water spray may be useful in minimizing or dispersing vapors and to protect personnel. Cool equipment exposed to fire with water, if it can be done safely. Avoid spreading burning liquid with water used for cooling purposes.

See Section 9 for Flammable Properties including Flash Point and Flammable (Explosive) Limits

SECTION 6: Accidental release measures

Personal precautions, protective equipment and emergency procedures: This material may burn, but will not ignite readily. Keep all sources of ignition away from spill/release. Stay upwind and away from spill/release. Avoid direct contact with material. For large spillages, notify persons down wind of the spill/release, isolate immediate hazard area and keep unauthorized personnel out. Wear appropriate protective equipment, including respiratory protection, as conditions warrant (see Section 8). See Sections 2 and 7 for additional information on hazards and precautionary measures.

Environmental Precautions: Stop and contain spill/release if it can be done safely. Prevent spilled material from entering sewers, storm drains, other unauthorized drainage systems, and natural waterways. Use water sparingly to minimize environmental contamination and reduce disposal requirements. If spill occurs on water notify appropriate authorities and advise shipping of any hazard. Spills into or upon navigable waters, the contiguous zone, or adjoining shorelines that cause a sheen or discoloration on the surface of the water, may require notification of the National Response Center (phone number 800-424-8802).

Methods and material for containment and cleaning up: Notify relevant authorities in accordance with all applicable regulations. Immediate cleanup of any spill is recommended. Dike far ahead of spill for later recovery or disposal. Absorb spill with inert material such as sand or vermiculite, and place in suitable container for disposal. If spilled on water remove with appropriate methods (e.g. skimming, booms or absorbents). In case of soil contamination, remove contaminated soil for remediation or disposal, in accordance with local regulations.

Recommended measures are based on the most likely spillage scenarios for this material; however local conditions and regulations may influence or limit the choice of appropriate actions to be taken. See Section 13 for information on appropriate disposal.

SECTION 7: Handling and storage

Precautions for safe handling: Keep away from flames and hot surfaces. Wash thoroughly after handling. Use good personal hygiene practices and wear appropriate personal protective equipment (see section 8). Spills will produce very slippery surfaces. High pressure injection of hydrocarbon fuels, hydraulic oils or greases under the skin may have serious consequences even though no symptoms or injury may be apparent. This can happen accidentally when using high pressure equipment such as high pressure grease guns, fuel injection apparatus or from pinhole leaks in tubing of high pressure hydraulic oil equipment.

Do not enter confined spaces such as tanks or pits without following proper entry procedures such as ASTM D-4276 and 29CFR 1910.146. Do not wear contaminated clothing or shoes.

Conditions for safe storage: Keep container(s) tightly closed and properly labeled. Use and store this material in cool, dry, well-ventilated area away from heat and all sources of ignition. Store only in approved containers. Keep away from any incompatible material (see Section 10). Protect container(s) against physical damage.

"Empty" containers retain residue and may be dangerous. Do not pressurize, cut, weld, braze, solder, drill, grind, or expose such containers to heat, flame, sparks, or other sources of ignition. They may explode and cause injury or death. "Empty" drums should be completely drained, properly bunged, and promptly shipped to the supplier or a drum reconditioner. All containers should be disposed of in an environmentally safe manner and in accordance with governmental regulations. Before working on or in tanks which contain or have contained this material, refer to OSHA regulations, ANSI Z49.1, and other references pertaining to cleaning, repairing, welding, or other contemplated operations.

SECTION 8: Exposure controls/personal protection

Chemical Name	ACGIH	OSHA	Phillips 66
Distillates, petroleum, hydrotreated heavy paraffinic	---	---	TWA: 5 mg/m ³ STEL: 10 mg/m ³ as Oil Mist, if Generated

Note: State, local or other agencies or advisory groups may have established more stringent limits. Consult an industrial hygienist or similar professional, or your local agencies, for further information.

Engineering controls: If current ventilation practices are not adequate to maintain airborne concentrations below the established exposure limits, additional engineering controls may be required.

Eye/Face Protection: The use of eye/face protection is not normally required; however, good industrial hygiene practice suggests the use of eye protection that meets or exceeds ANSI Z.87.1 whenever working with chemicals.

Skin/Hand Protection: The use of skin protection is not normally required; however, good industrial hygiene practice suggests the use of gloves or other appropriate skin protection whenever working with chemicals. Suggested protective materials: Nitrile

Respiratory Protection: Where there is potential for airborne exposure above the exposure limit a NIOSH certified air purifying respirator equipped with R or P95 filters may be used.

A respiratory protection program that meets or is equivalent to OSHA 29 CFR 1910.134 and ANSI Z88.2 should be followed whenever workplace conditions warrant a respirator's use. Air purifying respirators provide limited protection and cannot be used in atmospheres that exceed the maximum use concentration (as directed by regulation or the manufacturer's instructions), in oxygen deficient (less than 19.5 percent oxygen) situations, or under conditions that are immediately dangerous to life and health (IDLH).

Suggestions provided in this section for exposure control and specific types of protective equipment are based on readily available information. Users should consult with the specific manufacturer to confirm the performance of their protective equipment. Specific situations may require consultation with industrial hygiene, safety, or engineering professionals.

SECTION 9: Physical and chemical properties

Note: Unless otherwise stated, values are determined at 20°C (68°F) and 760 mm Hg (1 atm). Data represent typical values and are not intended to be specifications.

Appearance: Amber, Transparent	Flash Point: > 302 °F / > 150 °C (ASTMD93)
Physical Form: Liquid	Test Method: Pensky-Martens Closed Cup (PMCC), ASTM D93, EPA 1010
Odor: Petroleum	Initial Boiling Point/Range: No data
Odor Threshold: No data	Vapor Pressure: <1 mm Hg
pH: Not applicable	Partition Coefficient (n-octanol/water) (Kow): No data
Vapor Density (air=1): >1	Melting/Freezing Point: No data
Upper Explosive Limits (vol % in air): No data	Auto-ignition Temperature: No data
Lower Explosive Limits (vol % in air): No data	Decomposition Temperature: No data
Evaporation Rate (nBuAc=1): No data	Specific Gravity (water=1): 0.85-0.89 @ 60°F (15.6°C)
Particle Size: Not applicable	Bulk Density: No data
Percent Volatile: No data	Viscosity: 4.0 - 25 cSt @ 100°C; 21 - 345 cSt @ 40°C
Flammability (solid, gas): Not applicable	Pour Point: < 10 °F / < -12 °C
Solubility in Water: Negligible	

SECTION 10: Stability and reactivity

Reactivity: Not chemically reactive.

Chemical stability: Stable under normal ambient and anticipated conditions of use.

Possibility of hazardous reactions: Hazardous reactions not anticipated.

Conditions to avoid: Extended exposure to high temperatures can cause decomposition. Avoid all possible sources of ignition.

Incompatible materials: Avoid contact with strong oxidizing agents and strong reducing agents.

Hazardous decomposition products: Not anticipated under normal conditions of use.

SECTION 11: Toxicological information

Information on Toxicological Effects

Substance / Mixture			
Acute Toxicity	Hazard	Additional Information	LC50/LD50 Data
Inhalation	Unlikely to be harmful		>5 mg/L (mist, estimated)
Dermal	Unlikely to be harmful		> 2 g/kg (estimated)
Oral	Unlikely to be harmful		> 5 g/kg (estimated)

Aspiration Hazard: Not expected to be an aspiration hazard.

Skin Corrosion/Irritation: Not expected to be irritating.

Serious Eye Damage/Irritation: Not expected to be irritating.

Skin Sensitization: No information available on the mixture, however none of the components have been classified for skin sensitization (or are below the concentration threshold for classification).

Respiratory Sensitization: No information available.

Specific Target Organ Toxicity (Single Exposure): No information available on the mixture, however none of the components have been classified for target organ toxicity (or are below the concentration threshold for classification).

Specific Target Organ Toxicity (Repeated Exposure): No information available on the mixture, however none of the components have been classified for target organ toxicity (or are below the concentration threshold for classification).

Carcinogenicity: No information available on the mixture, however none of the components have been classified for carcinogenicity (or are below the concentration threshold for classification).

Germ Cell Mutagenicity: No information available on the mixture, however none of the components have been classified for germ cell mutagenicity (or are below the concentration threshold for classification).

Reproductive Toxicity: No information available on the mixture, however none of the components have been classified for reproductive toxicity (or are below the concentration threshold for classification).

Information on Toxicological Effects of Components

Distillates, petroleum, hydrotreated heavy paraffinic

Carcinogenicity: This oil has been highly refined by a variety of processes to reduce aromatics and improve performance characteristics. It meets the IP-346 criteria of less than 3 percent PAH's and is not considered a carcinogen by the International Agency for Research on Cancer.

SECTION 12: Ecological information

GHS Classification: No classified hazards

Toxicity: All acute aquatic toxicity studies on samples of lubricant base oils show acute toxicity values greater than 100 mg/L for invertebrates, algae and fish. These tests were carried out on water accommodated fractions and the results are consistent with the predicted aquatic toxicity of these substances based on their hydrocarbon compositions.

Persistence and Degradability: The hydrocarbons in this material are not readily biodegradable, but since they can be degraded by microorganisms, they are regarded as inherently biodegradable.

Bioaccumulative Potential: Log Kow values measured for the hydrocarbon components of this material are greater than 5.3, and therefore regarded as having the potential to bioaccumulate. In practice, metabolic processes may reduce bioconcentration.

Mobility in Soil: Volatilization to air is not expected to be a significant fate process due to the low vapor pressure of this material. In water, base oils will float and spread over the surface at a rate dependent upon viscosity. There will be significant removal of hydrocarbons from the water by sediment adsorption. In soil and sediment, hydrocarbon components will show low mobility with adsorption to sediments being the predominant physical process. The main fate process is expected to be slow biodegradation of the hydrocarbon constituents in soil and sediment.

Other adverse effects: None anticipated.

SECTION 13: Disposal considerations

The generator of a waste is always responsible for making proper hazardous waste determinations and needs to consider state and local requirements in addition to federal regulations. This material, if discarded as produced, would not be a federally regulated RCRA "listed" hazardous waste and is not believed to exhibit characteristics of hazardous waste. See Sections 7 and 8 for information on handling, storage and personal protection and Section 9 for physical/chemical properties. It is possible that the material as produced contains constituents which are not required to be listed in the SDS but could affect the hazardous waste determination. Additionally, use which results in chemical or physical change of this material could subject it to regulation as a hazardous waste. This material under most intended uses would become "Used Oil" due to contamination by physical or chemical impurities. Whenever possible, Recycle used oil in accordance with applicable federal and state or local regulations. Container contents should be completely used and containers should be emptied prior to discard.

SECTION 14: Transport information

U.S. Department of Transportation (DOT)

UN Number: Not regulated

UN proper shipping name: None

Transport hazard class(es): None

Packing Group: None

Environmental Hazards: This product does not meet the DOT/UN/IMDG/IMO criteria of a marine pollutant

Special precautions for user: If shipped by land in a packaging having a capacity of 3,500 gallons or more, the provisions of 49 CFR, Part 130 apply. (Contains oil)

Transport in bulk according to Annex II of MARPOL 73/78 and the IBC Code: Not applicable

SECTION 15: Regulatory information

CERCLA/SARA - Section 302 Extremely Hazardous Substances and TPQs (in pounds):

This material does not contain any chemicals subject to the reporting requirements of SARA 302 and 40 CFR 372.

CERCLA/SARA - Section 311/312 (Title III Hazard Categories)

Acute Health Hazard:	No
Chronic Health Hazard:	No
Fire Hazard:	No
Pressure Hazard:	No
Reactive Hazard:	No

CERCLA/SARA - Section 313 and 40 CFR 372:

This material does not contain any chemicals subject to the reporting requirements of SARA 313 and 40 CFR 372.

EPA (CERCLA) Reportable Quantity (in pounds):

This material does not contain any chemicals with CERCLA Reportable Quantities.

California Proposition 65:

This material does not contain any chemicals which are known to the State of California to cause cancer, birth defects or other reproductive harm at concentrations that trigger the warning requirements of California Proposition 65.

International Hazard Classification

Canada:

This product has been classified in accordance with the hazard criteria of the Hazardous Products Regulations (SOR/2015-17) and the SDS contains all the information required by the Regulations.

International Inventories

All components are either listed on the US TSCA Inventory, or are not regulated under TSCA. All components are either on the DSL, or are exempt from DSL listing requirements.

U.S. Export Control Classification Number: EAR99

SECTION 16: Other information

Issue Date:	Previous Issue Date:	SDS Number	Status:
28-Jun-2016	23-Jun-2016	LBPH814637	FINAL

Revised Sections or Basis for Revision: New SDS

Guide to Abbreviations:

ACGIH = American Conference of Governmental Industrial Hygienists; CASRN = Chemical Abstracts Service Registry Number; CEILING = Ceiling Limit (15 minutes); CERCLA = The Comprehensive Environmental Response, Compensation, and Liability Act; EPA = Environmental Protection Agency; GHS = Globally Harmonized System; IARC = International Agency for Research on Cancer; INSHT = National Institute for Health and Safety at Work; IOPC = International Oil Pollution Compensation; LEL = Lower Explosive Limit; NE = Not Established; NFPA = National Fire Protection Association; NTP = National Toxicology Program; OSHA = Occupational Safety and Health Administration; PEL = Permissible Exposure Limit (OSHA); SARA = Superfund Amendments and Reauthorization Act; STEL = Short Term Exposure Limit (15 minutes); TLV = Threshold Limit Value (ACGIH); TWA = Time Weighted Average (8 hours); UEL = Upper Explosive Limit; WHMIS = Worker Hazardous Materials Information System (Canada)

Disclaimer of Expressed and implied Warranties:

The information presented in this Safety Data Sheet is based on data believed to be accurate as of the date this Safety Data Sheet was prepared. HOWEVER, NO WARRANTY OF MERCHANTABILITY, FITNESS FOR ANY PARTICULAR PURPOSE, OR ANY OTHER WARRANTY IS EXPRESSED OR IS TO BE IMPLIED REGARDING THE ACCURACY OR COMPLETENESS OF THE INFORMATION PROVIDED ABOVE, THE RESULTS TO BE OBTAINED FROM THE USE OF THIS INFORMATION OR THE PRODUCT, THE SAFETY OF THIS PRODUCT, OR THE HAZARDS RELATED TO ITS USE. No responsibility is assumed for any damage or injury resulting from abnormal use or from any failure to adhere to recommended practices. The information provided above, and the product, are furnished on the condition that the person receiving them shall make their own determination as to the suitability of the product for their particular purpose and on the condition that they assume the risk of their use. In addition, no authorization is given nor implied to practice any patented invention without a license.

TABLE OF CONTENTS

Material Safety Data Sheet – VektorFlo Hydraulic Fluid

Preliminary Information (EN-5502).....	2
Specifications (Section I)	3
Installation and Operation (Section II).....	4
Maintenance and Service (Section III)	7
Parts List and Diagrams (Section IV)	10

PRELIMINARY INFORMATION**FAILURE TO HEED THE FOLLOWING INFORMATION WILL
VOID WARRANTY**

Most malfunctions of new equipment are the result of improper operation and/or improper set-up and assembly. Please read the enclosed information.

Remove the pump from the shipping container...but **DO NOT** remove any plugs or valves until the unit is ready to be fully assembled to prevent dirt or foreign matter from contaminating the system or oil.

Visually inspect all components for shipping damage. If any damage is found, notify the carrier immediately and contact the factory.

CAUTION: USE ONLY CYLINDERS, HOSES, AND EQUIPMENT RATED FOR 5,000 PSI OPERATING PRESSURE. USE OF CYLINDERS OR OTHER COMPONENTS RATED FOR LESS THAN 5,000 PSI MAY RESULT IN SYSTEM FAILURE, WHICH MAY RESULT IN BODILY INJURY OR PROPERTY DAMAGE.

This pump incorporates SAE O-Ring seal ports for all external hydraulic connections. SAE O-Ring fittings seal by compressing a resilient O-Ring in a specially designed chamfer in the port. With this type of connection, the use of Teflon® tape, pipe dope, or other similar materials is not allowed. Such materials may contaminate the hydraulic system and damage the sealing surfaces in precision valves. Detection of such material in the pump reservoir will void the warranty.

When connected to a properly functioning clamping system, hydraulic pressure may drop very slowly after the pump stops. The pump should restart only once every (5) to (10) minutes, depending on the size and complexity of the system.

CAUTION: UNDER NO CIRCUMSTANCES SHOULD THE PUMP RESTART MORE THAN ONCE PER MINUTE. FREQUENT PUMP RESTARTS INDICATES THAT SYSTEM LEAKAGE RATES ARE EXCESSIVE AND MUST BE LOCATED AND REPAIRED TO PREVENT PREMATURE PUMP FAILURE CAUSED BY CONSTANT STARTING AND STOPPING.

Leakage points may be either external (evidenced by visible fluid drips) or internal and thus, unseen. Consult factory for assistance if unable to locate or correct the problem.

Teflon is a registered trademark of Dupont Dow Elastomers®

SECTION I SPECIFICATIONS

Figure 1.1

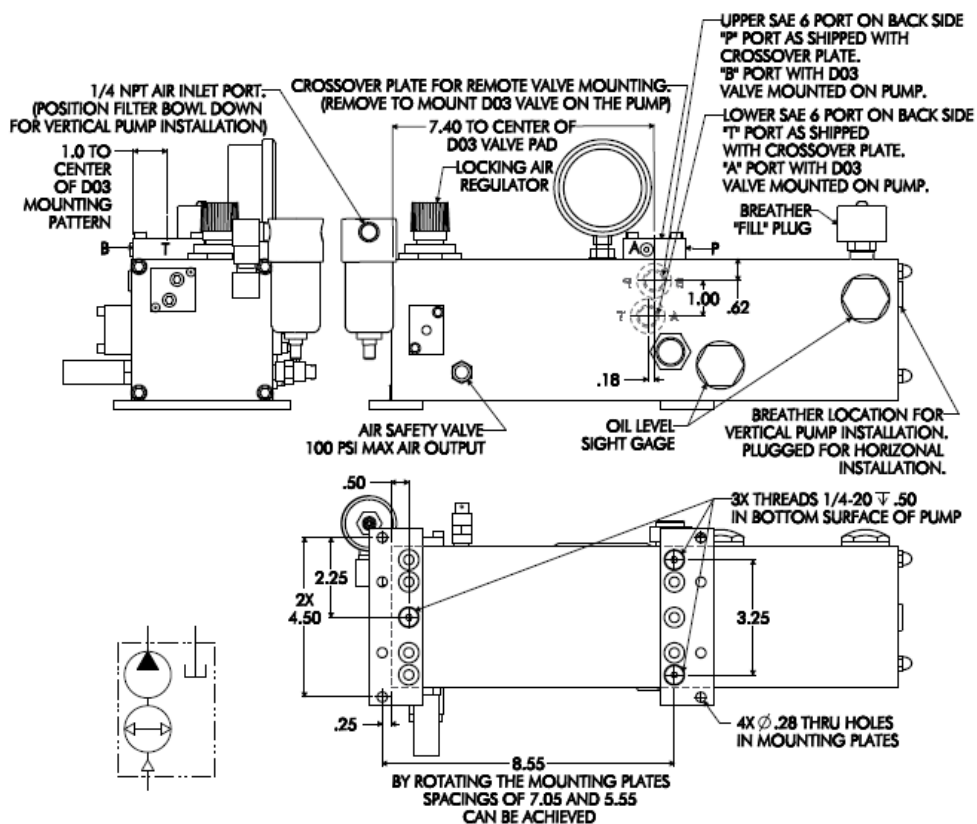
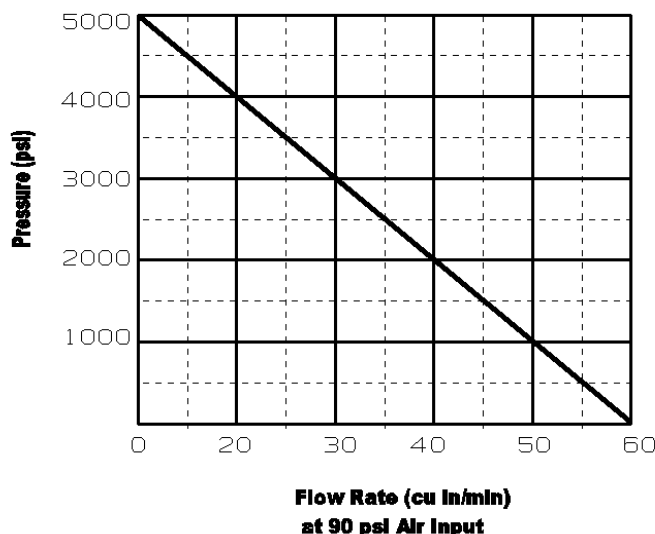

MODEL NO.	RESERVOIR CAPACITY CU. IN.	MINIMUM AIR INPUT PSI	MAXIMUM AIR INPUT PSI	OPERATING PRESSURE RANGE PSI	MOUNTING OPTIONS	ANODIZED ALUMINUM WEIGHT LBS
55-2056-00	HORIZONTAL 68	50	120	1200-5000	HORIZONTAL (AS SHOWN)	19
55-2056-00	VERTICAL 80	50	120	1200-5000	VERTICAL (RESERVOIR UP & FILTER BOWL DOWN)	19

SECTION II

INSTALLATION AND OPERATION

2.1 PRIOR TO OPERATION

The pump comes ready to operate. The only customer requirement is to install the following:

1. Install the gauge on top of pump (see Figure 1.1).
2. Install vent/fill plug into reservoir (see Figure 1.1).
3. Connect hydraulic lines to either the A or the A and B SAE 6 ports (see Figure 1.1).
4. If a valve is needed at the pump, remove the crossover plate and mount a "zero leak" valve on the D03 pad (see Figure 1.1). If a remote valve is needed, mount the valve onto a valve sub-plate (70-9411-00) at the fixture.
5. Connect the air line to to filter (1/4 NPT) (see Section 2.2 and Figure 1.1).

2.2 CHECK LIST

Before putting air to the unit, it is necessary to go through the following check list to ensure proper operation.

1. Be sure that all hydraulic fittings, hoses, etc., are rated at 5000 psi.
2. Use an air hose with a minimum 3/8 in. ID.
3. Air supply must be free of contaminants and an air filter/separator installed as close as possible to the pump.
4. Lubricated air must **not** be used.
5. Be sure that the regulator is completely closed before connecting to air line. (Pull knob and rotate counter-clockwise until completely closed.)

2.3 RESERVOIR FILLING AND DRAINING

It is recommended that VektorFlo hydraulic oil (Cat. No. 65-0010-01, one gallon) be used. VektorFlo hydraulic oil is a premium grade petroleum-based fluid with detergent and anti-wear additives. It also includes additives to inhibit corrosion and foaming. VektorFlo hydraulic oil has the following additional characteristics:

Pour Point: <5° F.	Viscosity (SUS) 100° F.: 160
Flash Point: >302° F.	210° F.: 44.4
	ISO Viscosity Grade: 32

Consult a VEKTEK catalog if your application requires anything other than light viscosity petroleum-based fluids.

TO FILL: Remove the vent/fill plug. Add clean oil through a strainer into the reservoir until full. Replace the vent/fill cap. Refill the reservoir after the system is bled (Section 2.4).

TO DRAIN: Pump oil out until the unit begins to cavitate (cycles rapidly). Disconnect from the air supply. Remove the vent/fill plug. Turn the unit upside and allow the remainder of the oil to drain out.

SECTION II

INSTALLATION AND OPERATION (Continued)

2.4 BLEEDING AIR FROM YOUR SYSTEM

Bleeding air from any hydraulic system can be a tedious task. The following suggestions should help expedite the procedure.

Air naturally moves toward the highest point in the system or device. Elevating the pump to a height greater than the fixture devices and cycling the control valve several times will usually remove most of the air. The air bubbles will seek the highest point in the circuit and be released into the pump reservoir.

To bleed the system, connect the air supply hose and slowly turn the regulator clockwise until the pump begins to reciprocate. Shift the hydraulic control valve and allow the unit to cycle until the oil has filled the entire system. Depressurize the hydraulic system and repeat until the system has been completely bled. After the system is bled, the adjustment knob can be rotated in the clockwise direction until the desired outlet pressure is reached. Push down on the adjustment knob to lock the adjustment knob.

If a system proves difficult to bleed, using the above method, turn the pump on, move the valve to the advance/clamp position and carefully loosen the hydraulic fitting at the device. Usually only 1/2 to 3/4 turn of the nut is required for air/oil to leak out from the connection. The appearance of "milky" colored oil from this connection indicates that air is being evacuated. While still under pressure, re-tighten the fitting before turning off the pump, to prevent re-entry of air back into the system. Turn the pump off, recheck and re-tighten the fitting as required before proceeding to the next fitting.

Sluggish or "jerky" device action is usually the first sign of air in a hydraulic system. Accordingly, removal of as much air as possible by the methods described above will help your system function smoothly.

SECTION II

INSTALLATION AND OPERATION (Continued)

2.5 PUMP MOUNTING POSITION

2.5.1 Horizontal pump mounting position shown below with reservoir breather installed in top surface and plug in the left end of the reservoir (not shown).



2.5.2 Vertical pump mounting position shown below with reservoir breather installed in the top end of the reservoir and plug in the front right surface.



SECTION III

MAINTENANCE AND SERVICE

3.1 GENERAL

Due to the modular design, it is easily maintained and readily serviced. Upon receipt of the unit, inspect the assembly thoroughly. Check the pressure gauge, air pressure regulator, mufflers, reservoirs and valves for signs of physical damage. If damaged, first consult the shipping company and then VEKTEK for corrective repair action. Before operating the unit, follow the guidelines described in Section 2.

3.2 TROUBLE SHOOTING GUIDE

If a problem develops with the pump, the following guide will help to diagnose the problem and suggest a remedy.

PROBLEM	PROBABLE CAUSE(S)	SUGGESTED REMEDY
Pump stops cycling	2-way air valve failure	Replace one or both air valves (P/N 55-2500-38)
	Contaminated air supply	Clean all internal air cap parts thoroughly, replace or clean inline air filter at pump inlet
	Inadequate air supply	See Section 2.2 for air inlet requirements
Pump cycles when regulator is backed out	Pressure regulator failure	Replace regulator (P/N 55-2500-15)
Oil comes out of muffler(s) in air section	Use of air lubricator	Remove air lubricator to pump
	Ratio plate seal failure caused by contaminated oil supply	Factory repair
Oil leaks out between pump and reservoir	Reservoir gasket failure	Replace reservoir gasket (P/N 55-2500-22)
Oil leaks out between hydraulic body and ratio plate – oil breather on ratio plate	O-ring failure	Replace main O-ring (P/N 55-2500-07) between hydraulic body and ratio plate (see Section 3.3 for hints on assembly)

SECTION III

MAINTENANCE AND SERVICE (Continued)

3.2 TROUBLE SHOOTING GUIDE (continued)

PROBLEM	PROBABLE CAUSE(S)	SUGGESTED REMEDY
Pump does not reach/hold desired pressure, pump cycles	Check valve failure	Clean check valves and replace if damaged
	Piston seal failure caused by contaminated oil	Factory repair
	Oil leakage	Check all fitting connections
Pump does not reach desired pressure – pump does not cycle	Reduced air inlet supply	Check inlet air pressure
	Gauge failure	Check hydraulic gauge calibration
	Mechanical bind between piston and bore	Check alignment (see Section 3.3)
Pump reaches pressure – air hisses out of mufflers	T-seal failure caused by contaminated air	Replace T-seals (P/N 55-2500-02), also check air supply and filter

3.3 GENERAL ASSEMBLY

The general assembly consists of four major sub-assemblies; the air cap, the air body, the ratio plate with piston and rod, and the hydraulic body. It is most efficient if each of these four sub-assemblies are sub-assembled prior to final assembly. It is strongly recommended that the piston never be removed from the piston shaft, as any damage to the seals is not covered under warranty if damaged in repair.

3.4 ASSEMBLING THE AIR CAP

When servicing the air cap, make sure that all of the internal parts are clean and in the proper order. Do not forget the O-rings on the two pilot caps. Be sure the spool, cages, and T-seals have not been damaged. Before assembly, lubricate the spool and T-seals with a light even coat of white lithium grease. Plugged construction holes should never be touched.

SECTION III

MAINTENANCE AND SERVICE (Continued)**3.5 MOUNTING RATIO PLATE TO HYDRAULIC BODY**

Check to make sure that the two sections are entirely sub-assembled, and all parts are clean. Lubricate the hydraulic bore and piston with hydraulic oil. Put a thin film of hydraulic oil on the o-rings. Be sure all the O-rings are in their original place. Gently insert the hydraulic piston into the bore. Use the air valve actuator to line up the center plate to the body. At this point, check to see that no shearing of the piston seal has occurred, by looking for any residual seal pieces in the bore. Push the center plate down until it contacts the bore face of the hydraulic body. Exercise the hydraulic piston up and down by pushing and pulling on the air piston while holding down the center plate. Insert the center plate cap screws (1/4-20 x 1) with lock washers. Tighten the screws until just snug. Exercise the piston again. Torque the cap screws in a cross pattern to 15 ft. lbs. Again, exercise the piston. No mechanical binding should be evident.

3.6 MOUNTING THE AIR BODY TO THE RATIO PLATE

Make sure the ratio plate is secured to the hydraulic body and that the air valve actuator is in place. Clean the bore of the air body and the air piston. Pull the air piston to the top of its stroke. Place the air gasket over the piston and line it up on the center plate. When the air body is aligned correctly, the nameplate with the model and serial numbers is on the top of the unit, with the bottom of the nameplate facing toward the center plate. Check the orientation by noting that the chamfer on the bore of the air body is facing the center plate. Apply a light even coat of white lithium grease to the bore and the air piston seal. Gently work the air body over the air piston. Push the body down onto the gasket on the ratio plate.

3.7 MOUNTING THE AIR CAP TO THE AIR BODY

Be sure the air cap is fully assembled before mounting it to the air body. Place gasket (55-2500-28) on the air body and align to the edges. Place the air cap on the air body with the air regulator toward the top.

Align the bottom faces of the air cap through the air body and ratio plate to the hydraulic body by using the four cap screws (5/16-18 x 4 1/2") and lock washers. Snug the bolts using a cross pattern.

Connect a temporary air supply to the pump (NO OIL YET) and be sure the air pressure regulator (55-2500-15) is turned fully (counter-clockwise). Slowly rotate the air pressure regulator knob clockwise until the pump starts reciprocating. While running, tighten all four air cap screws to approximately 20 lbf·ft using a cross pattern. If the pump stalls or binds during tightening, remove all air pressure, loosen all four cap screws and restart the procedure.

SECTION IV
PUMP SECTIONS

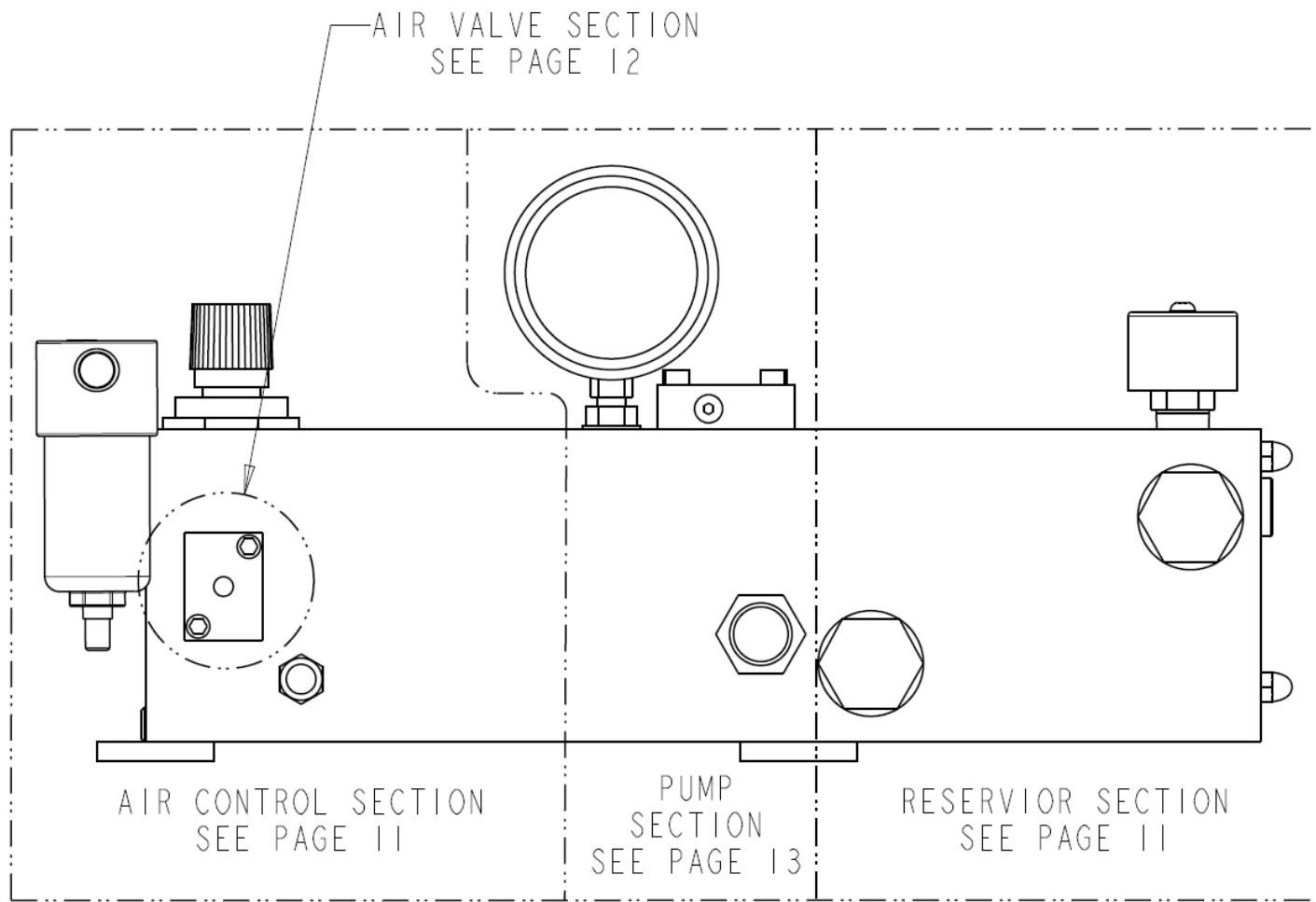

Complete pump rebuild kit PN: 62-5520-04
See page 15 for kit BOM

SECTION IV

PUMP SECTIONS (Continued)

AIR CONTROL SECTION

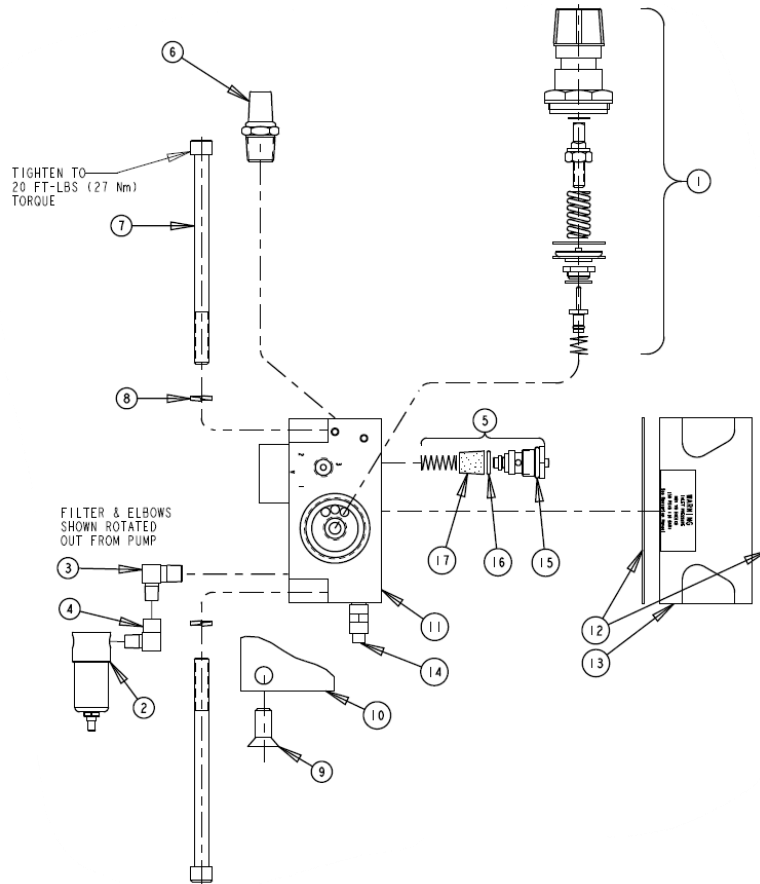

	ITEM	QTY	PART NUMBER	DESCRIPTION
	1	1	55-2500-15	AIR REG ASSY
	2	1	50-1440-00	AIR FILTER ASSY
	3	1	30-1033-64	ELBOW, 90°, 3/8 NPT – 1/4 NPT
	4	1	30-1034-44	ELBOW, STREET, 90°, NPT
	5	1	55-2500-38	TWO-WAY AIR VALVE
+	6	1	55-2500-34	MUFFLER
	7	4	5/16-18 x 4.5"	S.H.C.S.
	8	4	5/16 HI COLLAR	LOCK WASHER
	9	3	21-4100-24	FL. HD. CAP SCREW
	10	2	85-5400-05	BRACKET
	11	1	OP-160	AIR CAP HOUSING
	12	2	55-2500-28	AIR BODY GASKET
	13	1	EP-200	AIR BODY
	14	1	55-2500-45	VALVE RELIEF
+	15	1	39-0000-37	O-RING
+	16	1	39-0020-09	O-RING
+	17	1	55-2500-46	FILTER, TWO-WAY VALVE

+ INCLUDED IN COMPLETE PUMP REBUILD KIT 62-5520-04

**SECTION IV
PUMP SECTIONS (Continued)**

AIR VALVE SECTION

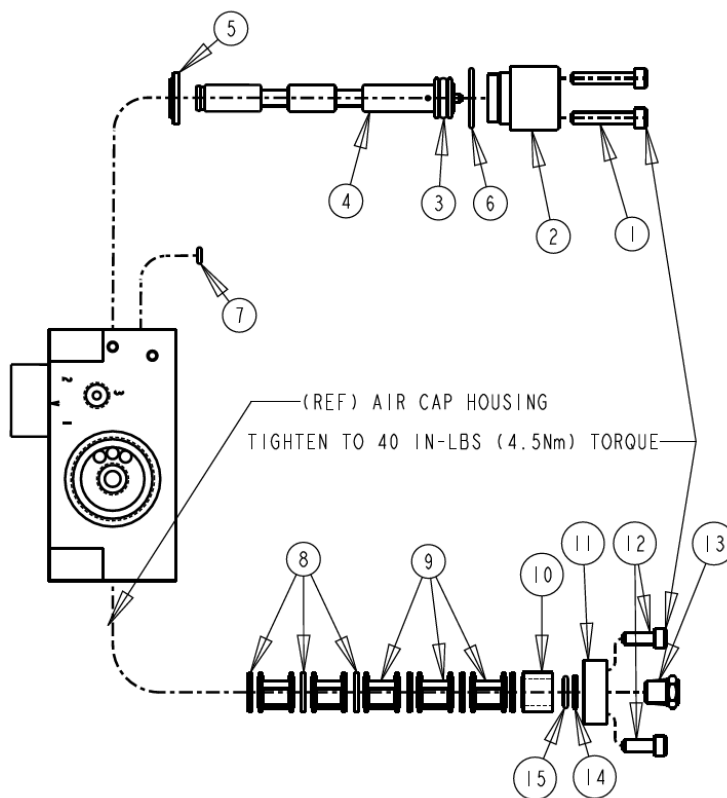

ITEM	QTY	PART NUMBER	DESCRIPTION
1	2	10-24 X 1"	S.H.C.S.
2	1	EP-159-2	PILOT CAP
+ *	3	55-2500-39	O-RING
	4	55-2500-43	AIR SPOOL
	5	EP-158	BUSHING (SHORT)
++	6	39-0500-58	O-RING
++	7	55-2500-41	O-RING
++	8	55-2500-02	TEE-SEAL
	9	EP-104	CAGE
	10	EP-157	BUSHING (LONG)
	11	EP-159-1	SPOOL CAP
	12	10-24 x 1/2"	S.H.C.S.
+	13	55-2500-35	BREATHER
+	14	39-0540-10	BU. RING
+	15	39-0511-89	O-RING

* INCLUDED IN AIR VALVE SECTION REPAIR KIT 62-5556-01
 + INCLUDED IN COMPLETE PUMP REBUILD KIT 62-5520-04

SECTION IV PUMP SECTIONS (Continued)

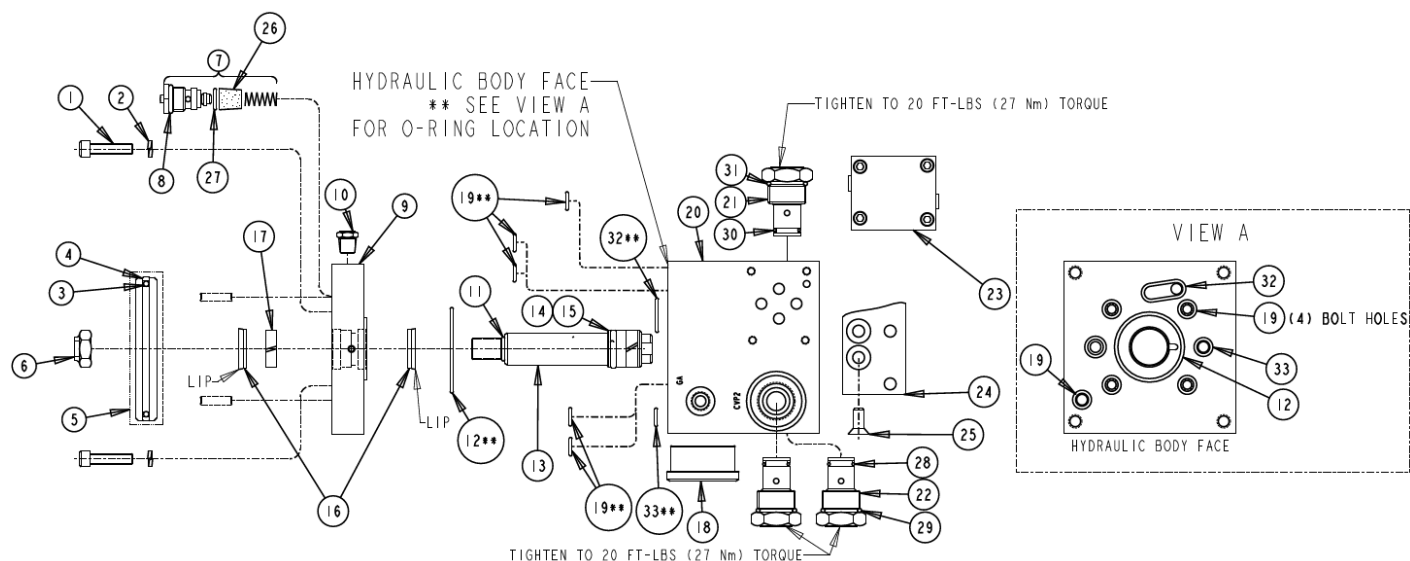

* INCLUDED IN PUMP SECTION REPAIR KIT 62-5556-02
+ INCLUDED IN COMPLETE PUMP REPAIR KIT 62-5520-04

ITEM	QTY	PART NUMBER	DESCRIPTION	ITEM	QTY	PART NUMBER	DESCRIPTION
1	4	¼-20 NC x 1"	S.H.C.S.	18	1	72-2121-62	GAGE
2	4	¼ HI COLLAR	LOCK WASHER	**	19	55-2500-05	O-RING
+	3	55-2500-03	O-RING	20	1	(NON-REP. PART)	HYDRAULIC BODY
+	4	55-2500-04	PISTON SEAL	21	1	55-2500-18	CHECK VALVE (RV1)
5	1	55-2500-29	AIR PISTON ASSY	22	2	55-2500-42	CHECK VALVE (CVP 1&2)
6	1	EP-304	LOCK NUT	23	1	93-1989-00	CROSS-OVER ASSY
7	1	55-2500-38	VALVE ACTUATOR	24	1	85-5400-05	BRACKET
**	8	39-0000-37	O-RING	25	2	21-4100-24	FL. HD. CAP SCREW
9	1	EP-320	RATIO PLATE	+	26	55-2500-46	TWO-WAY FILTER
**	10	55-2500-35	BREATHER	**	27	39-0020-09	O-RING
**	11	55-2500-53	O-RING	**	28	39-0000-39	O-RING
**	12	55-2500-07	O-RING	**	29	39-0000-56	O-RING
13	1	OP-305	PISTON & ROD	**	30	39-0000-30	O-RING
+	14	55-2500-00	O-RING	**	31	39-0000-27	O-RING
+	15	55-2500-08	PISTON SEAL	**	32	39-0500-60	O-RING
**	16	55-2500-10	ROD SEAL	**	33	39-0000-42	O-RING
**	17	55-2500-12	WEAR RING				

SECTION IV

PUMP SECTIONS (Continued)
RESERVOIR SECTION

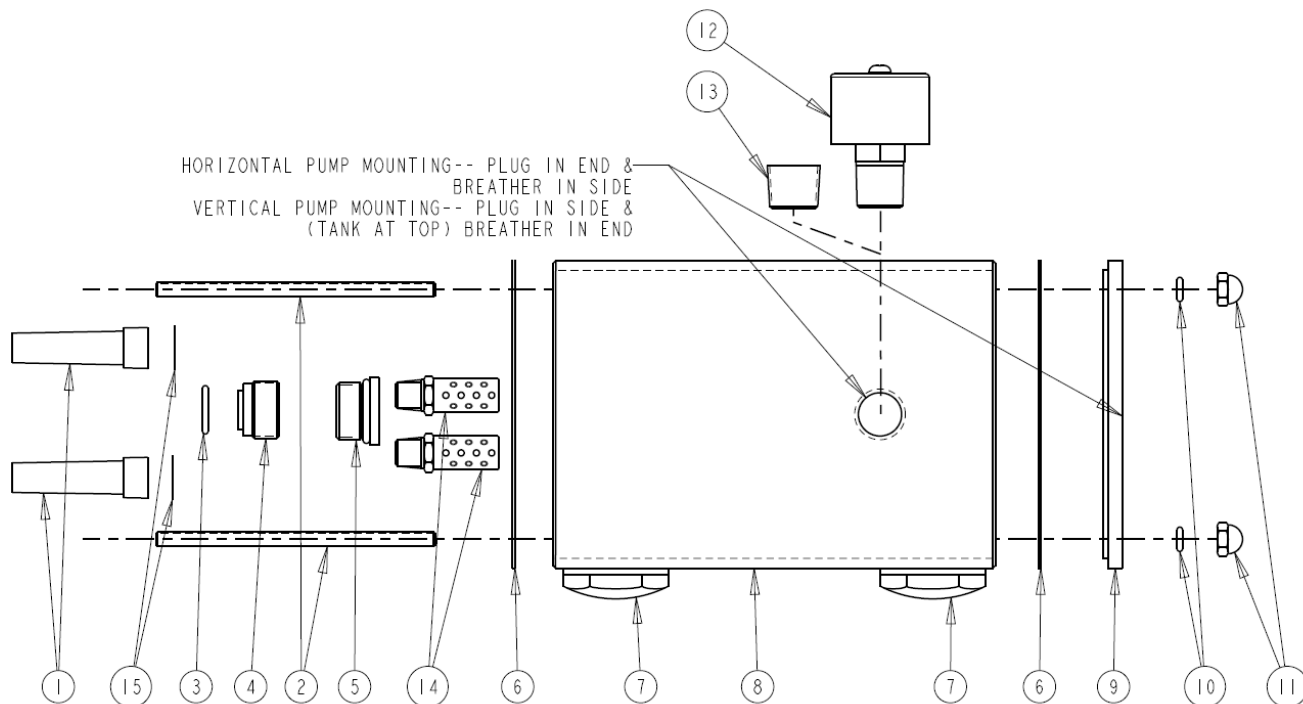

	ITEM	QTY	PART NUMBER	DESCRIPTION
+ *	1	2	55-2500-21	STRAINER
	2	4	OP-581	STUD
+ *	3	1	55-2500-11	O-RING
	4	1	55-2500-17	CHECK VALVE
	5	1	30-6011-99	PLUG
**	6	2	55-2500-22	GASKET
	7	2	10364	SIGHT GAGE
	8	1	OP-580	RESERVOIR SHELL
	9	1	OP-504	RESERVOIR CAP
**	10	4	39-0000-09	O-RING
	11	4	10-24	ACORN NUT
+	12	1	85-5944-12	BREATHER
	13	1	55-2500-31	PLUG (NPT)
**	14	2	55-2500-20	DIFFUSER, 1/8 NPT
	15	2	55-2500-30	STAR WASHER

* INCLUDED IN RESERVOIR SECTION REPAIR KIT 62-5556-03
 + INCLUDED IN COMPLETE PUMP REPAIR KIT 62-5520-04

Apply PTFE tape to pipe threads.

Apply lubricant to all seals prior to installation.
 Do not use silicone type lubricants.

55-2056-00 AIR HYDRAULIC COMPLETE PUMP REBUILD KIT (62-5520-04)

ITEM	QTY	PART NUMBER	DESCRIPTION	DRAWING PAGE	ITEM NO.
1	1	55-2500-34	MUFFLER, 3/8 NPT	11	6
2	1	39-0000-37	O-RING, -906, SAE 6, 70 NBR	11	14
3	1	39-0020-09	O-RING, -012, 3/8 X 1/16, 70 NBR	11	15
4	1	55-2500-46	FILTER, TWO-WAY VALVE	11	16
5	1	55-2500-39	O-RING, 7/16 X 3/32, 70 NBR	12	3
6	1	39-0500-58	O-RING, 13/16 X 1/16, 70 NBR	12	6
7	1	55-2500-41	O-RING, 1/8 X 1/16, 70 NBR	12	7
8	6	55-2500-02	SEAL, TEE	12	8
9	1	55-2500-35	BREATHER, 1/8 NPT	12	13
10	1	39-0540-10	RING, BACKUP, TEFLON, -012	12	14
11	1	39-0511-89	O-RING, -012, 3/8 X 1/16, 70 AU	12	15
12	1	55-2500-03	O-RING, 3 X 1/8, 70 NBR	13	3
13	1	55-2500-04	SEAL, PISTON	13	4
14	1	39-0000-37	O-RING, -906, SAE 6, 70 NBR	13	8
15	1	55-2500-35	BREATHER, 1/8 NPT	13	10
16	1	55-2500-53	O-RING, SAE 5, 70 NBR	13	11
17	1	55-2500-07	O-RING, 1-1/2 X 1/16, 90 AU	13	12
18	1	55-2500-00	O-RING, 1/2 X 3/32, 70 NBR	13	14
19	1	55-2500-08	SEAL, PISTON, 7/8	13	15
20	2	55-2500-10	SEAL, ROD	13	16
21	2	55-2500-12	RING, WEAR, PISTON	13	17
22	5	55-2500-05	O-RING, 5/16 X 1/16, 70 NBR	13	19
23	1	55-2500-46	FILTER, TWO-WAY VALVE	13	26
24	1	39-0020-09	O-RING, -012, 3/8 X 1/16, 70 NBR	13	27
25	2	39-0000-39	O-RING, -014, 1/2 X 1/16, 90 AU	13	28
26	2	39-0000-56	O-RING, -116, 3/4 X 3/32, 90 AU	13	29
27	1	39-0000-30	O-RING, -014, 1/2, 1/16, 70 NBR	13	30
28	1	39-0000-27	O-RING, -116, 3/4 X 3/32, 90 NBR	13	31
29	1	39-0500-60	O-RING, -017, 11/16 X 1/16, 70 NBR	13	32
30	1	39-0500-42	O-RING, -011, 5/16 X 1/16, 90 AU	13	33
31	2	55-2500-21	STRAINER	14	1
32	1	55-2500-11	O-RING, 16mm X 2mm, 70 NBR	14	3
33	2	55-2500-22	GASKET, RESERVOIR	14	6
34	4	39-0000-09	O-RING	14	10
35	2	55-2500-20	DIFFUSER, 1/8 NPT	14	14