

IMPORTANT FOR THIS PNEUMATIC ASSEMBLY ONLY
NOTE LOCATION OF PLATE 85600553 ORIENTATION HOLE

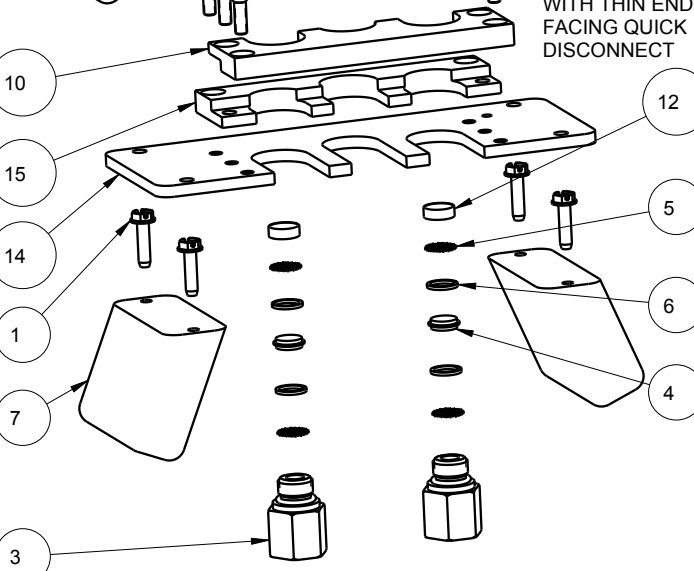
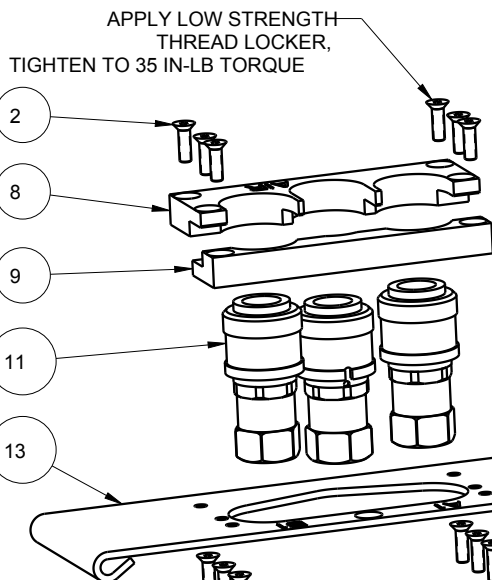
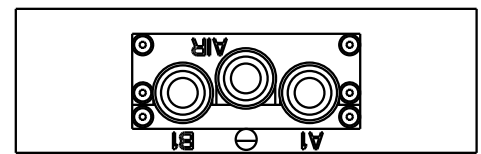
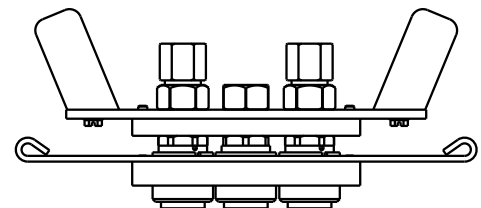

APPLY LOW STRENGTH
THREAD LOCKER,
TIGHTEN TO 35 IN-LB TORQUE

APPLY LOW STRENGTH
THREAD LOCKER,
TIGHTEN TO 35 IN-LB TORQUE

INSTALL
SPACER
WITH THIN END
FACING QUICK
DISCONNECT

TORQUE TO
23 FT-LB

NO	QTY	PART NO	DESCRIPTION
1	4	21410064	SCREW, HEXH, 10-24 X 3/4, SLF TPG
2	12	21410067	FLAT HEAD CAP SCREW, 10-32 x 5/8
3	2	30791266	FITTING, SAE 6, MALE- FEMALE
4	2	31050001	FILTER SCREEN, SAE 6, 178 MICRON
5	4	31050013	DIFFUSER, DISK, SAE 6
6	4	39054010	BU RING, (-012)
7	2	85600506	PULL HANDLE
8	1	85600516	PLATE, TRAP, PD, DUAL, 5000
9	1	85600537	PLATE, TRAP, PD, DUAL, 5000
10	1	85600543	PLATE, TRAP, TOP, PD, DUAL
11	3	85600544	COUPLER, QD, SAE 6, FEM, MODIFIED
12	2	85600549	SPACER, QD FILTER, SAE 6
13	1	85600551	PLATE, PD, 2H, .120 THK
14	1	85600553	PLATE, PD, 2H, .188 THK
15	1	85600707	PLATE, TRAP, BOTTOM, PD, DUAL

PARTS LIST



VEKTEK, INC.
1334 E. SIXTH AVE. P.O. BOX 625
EMPORIA, KS. 66801 U.S.A.

ASSEMBLIES AFFECTED
56-0007-01

PARTS LIST, ASSY, HANDLE, PD, 2H, 5000, PNEU

SIZE
A **PL5631**

REV
D

D	3191	RELEASE	MAJ	02/13/17
REV	IN ACCORDANCE WITH ECN	EFFECTIVE DATE	REVISED BY	DATE
DRW BY: MAJ	DRAWING STATUS: Released			
DATE: 2/13/12	PRODUCTION APPROVED FOR RELEASED STATUS ONLY			

FORM FEG035_PL_ASIZE, REV. B

SHEET 1 OF 1