



VEKTEK, INC.
1334 E. SIXTH AVE.
P.O. BOX 625
EMPORIA, KS. 66801
U.S.A.

PARTS LIST

PL-7094

REV L
ECN 2503

ASSEMBLIES AFFECTED: 15222101
15222101F

DRAWN/DATE

ROMINE
06/18/01

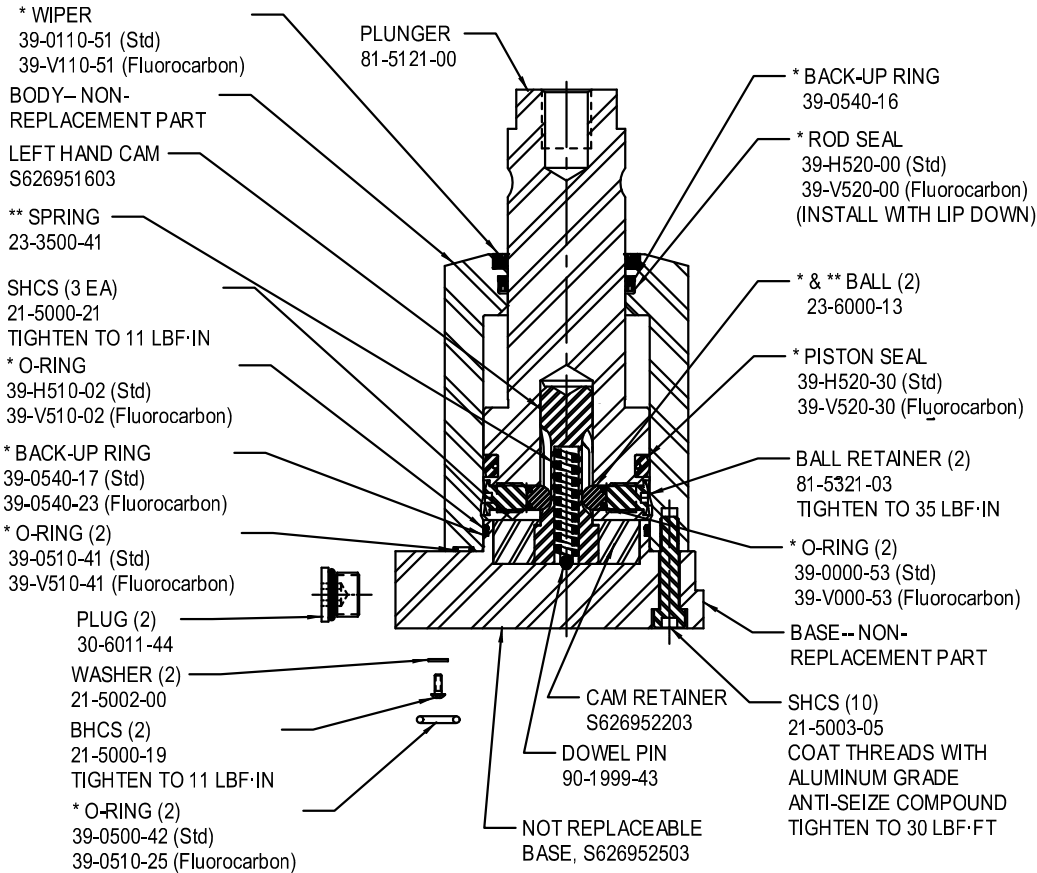

ASSY, SC, LP, BF, 7500, DA, LH

UNIT WITH PLUNGER CLUTCH
MODELS THAT APPLY
15222101 , Revision C & Earlier
15222101F , Revision C & Earlier

* INCLUDED IN SEAL KIT (Std) No. 60-7110-22
(Fluorocarbon) 6V-7110-13
** INCLUDED IN SPRING KIT No. 61-7040-07
APPLY LUBRICANT TO ALL SEALS
PRIOR TO INSTALLATION
DO NOT USE SILICONE TYPE LUBRICANTS.
FOR PROPER ARM MOUNTING SEE IS-1505

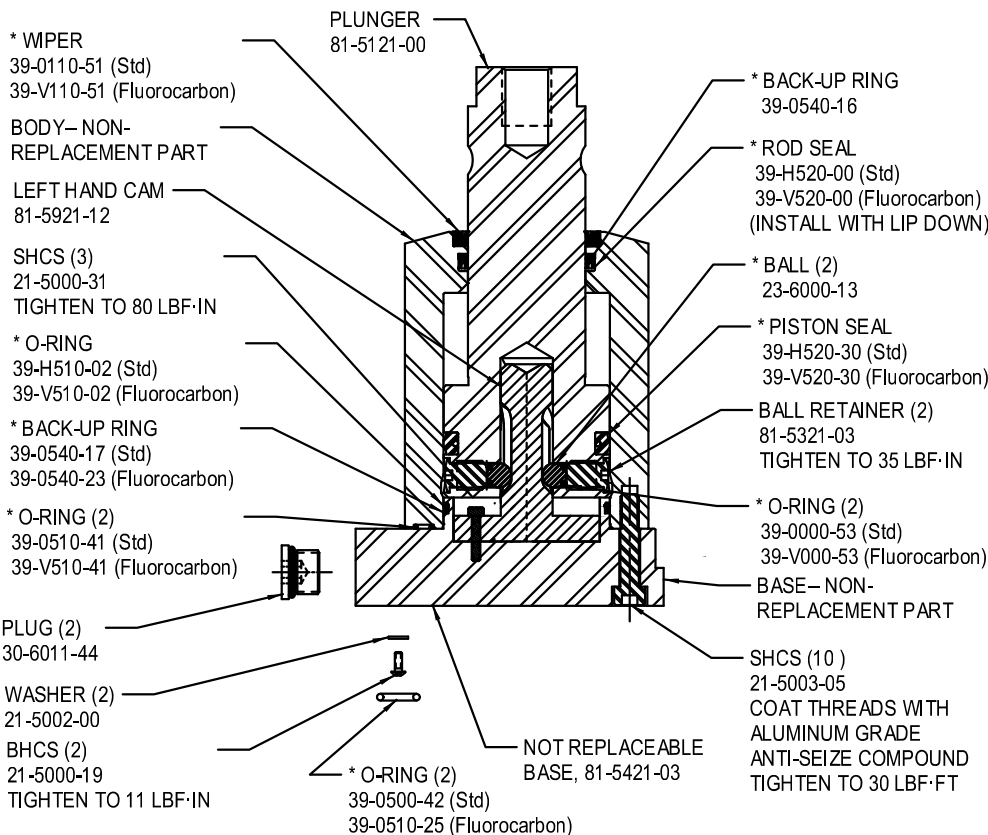

ASSY, SC, LP, BF, 7500, DA, LH

UNIT WITHOUT PLUNGER CLUTCH
AS OF 11/09/04
MODELS THAT APPLY
15222101 , Revision D & Later
15222101F , Revision D & Later

* INCLUDED IN SEAL KIT (Std) No. 60-7110-22
(Fluorocarbon) 6V-7110-13
APPLY LUBRICANT TO ALL SEALS
PRIOR TO INSTALLATION
DO NOT USE SILICONE TYPE LUBRICANTS.
FOR PROPER ARM MOUNTING SEE IS-1505

