

APPLY LUBRICANT TO ALL SEALS
PRIOR TO INSTALLATION.
DO NOT USE SILICONE TYPE LUBRICANTS.
FOR PROPER ARM MOUNTING SEE IS1505.

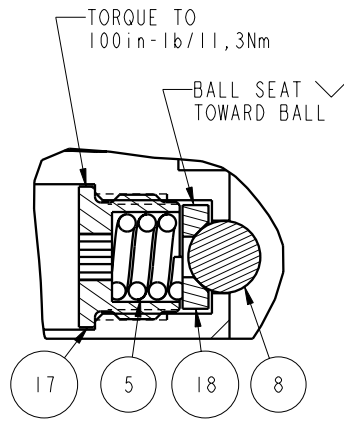

DETAIL A
SCALE 1.500

No.	QTY	PART No.	DESCRIPTION	Std. Seal Kit	FKM Seal Kit	Spring Kit
N/A	N/A	IS1505	INSTRUCTION SHEET, ARM INSTALLATION			
N/A	N/A	61704033	SPRING KIT			
N/A	N/A	6V711043	SEAL KIT, FKM			
N/A	N/A	60711043	SEAL KIT, STANDARD			
27	1	39V11051	WIPER, PRESS-IN, 1-1/2", 85 FKM	X	X	
26	1	39H52001	SEAL, BEV, 1-3/4x3/16x2-1/8, 85 HNBR	X	39V52001	
25	1	39H52000	SEAL, BEV, 1-1/2x1/8x1-3/4, 85 HNBR	X	39V52000	
24	1	39H51002	O-RING, (-033), 1.989x.070, 90 HNBR	X	39V51002	
23	1	92090001	ASSY, BREATHER, SAE #4			
22	1	81592122	CAM, SC, LP, 7500/33KN, LH, TC			
21	1	81592100	DISK, Ø1.00 X .19			X
20	1	81542103	BASE, SC, BF, LP, 7500			
19	1	81532111	PLUG, SC, LP, 7500/33KN, SA, TC			
18	3	81532108	SEAT, BALL, SC, LP, TC			
17	3	81532107	RETAINER, SC, LP, TC			
16	1	81512110	PLUNGER, SC, LP, 7500/33KN, SA, TC			
15	1	39054018	BU RING, (-327), HYTREL, CUT	X	X	
14	1	39054017	BU RING, (-033), 90 NBR	X	39054023	
13	1	39054016	BU RING, 1.5x.125x.063, HYTREL	X	X	
12	2	39051041	O-RING, (-006), .114x.070, 90 HNBR	X	39V51041	
11	2	39050042	O-RING, (-011), .301x.070, 90 AUD	X	39051025	
10	1	39001056	O-RING, (-119), .924x.103, 70 NBR	X	X	X
9	1	30601144	PLUG, SOCH, SAE 4			
8	3	23650004	BALL, TUNGSTEN-CARBIDE .250			
7	1	23600011	BALL, STEEL, ALLOY, .187			X
6	1	23350068	SPRING, COMP, 1.01X.192X6.22X3.68, 199			X
5	3	23350066	SPRING, COMP, .296X.06X.31X.21, 903			
4	10	21500305	SHCS, M8 X 1.25-6G X 30MM			
3	2	21500200	WASHER, .124x.207x.024, COPPER			
2	3	21500031	SHCS, M5 X 0.8 X 14, ALY			
1	2	21500019	SCREW, CAP, BTNH, M3 X 6, ALY			

PARTS LIST



VEKTEK, INC.
1334 E. SIXTH AVE. P.O. BOX 625
EMPORIA, KS. 66801 U.S.A.

ASSEMBLIES AFFECTED
14212101
14212101F

SIZE A
PL7172

REV B

B	2596	RELEASE	JDW	12/06/13
REV	IN ACCORDANCE WITH ECN	EFFECTIVE DATE	REVISED BY	DATE
DRW BY:	JDW	DRAWING STATUS: Released		
DATE:	6-17-11	PRODUCTION APPROVED FOR RELEASED STATUS ONLY		

